

I.V.A.S Industria Vernici S.p.A

Via Bellaria, 40
I-47030
San Mauro Pascoli (FC)
Italy

Tel: 01189 635 900 Fax: 01189 635 901

e-mail: enquiries@gruppoivas.co.uk

website: www.gruppoivas.com



Agrément Certificate

11/4841

Product Sheet 1

TERMOK8 EXTERNAL WALL INSULATION SYSTEMS

TERMOK8 ADHESIVELY BONDED EXTERNAL WALL INSULATION RENDER SYSTEMS

This Agrément Certificate Product Sheet⁽¹⁾ relates to TermoK8 Adhesively Bonded External Wall Insulation Render Systems, comprising adhesively fixed white or grey expanded polystyrene (EPS), phenolic foam (PF) or polyisocyanurate (PIR) insulation boards, with supplementary mechanical fixings, reinforced basecoat, and either render or brick slip finishes. The systems are suitable for use, with height restrictions, on the outside of external masonry walls in new and existing domestic and non-domestic buildings.

(1) Hereinafter referred to as 'Certificate'.

CERTIFICATION INCLUDES:

- factors relating to compliance with Building Regulations where applicable
- factors relating to additional non-regulatory information where applicable
- independently verified technical specification
- assessment criteria and technical investigations
- design considerations
- installation guidance
- regular surveillance of production
- formal three-yearly review.

KEY FACTORS ASSESSED

Thermal performance — the systems can be used to improve the thermal performance of external walls, and can contribute to satisfying the requirements of the national Building Regulations (see section 6).

Strength and stability — the systems can adequately resist wind loads and have sufficient resistance to impact damage. The impact resistance is dependent on the finish chosen (see section 7).

Behaviour in relation to fire — the systems have a B-s1, d0 or B-s2, d0 reaction to fire classification in accordance with UNI EN 13501-1 : 2019, depending on the system chosen and their use is restricted (see section 8).

Risk of condensation — the systems can contribute to limiting the risk of interstitial and surface condensation (see section 11).

Durability — when installed and maintained in accordance with the Certificate holder's recommendations and the terms of the Certificate, the systems will remain effective for at least 30 years (see section 13).

The BBA has awarded this Certificate to the company named above for the systems described herein. These systems have been assessed by the BBA as being fit for their intended use provided they are installed, used and maintained as set out in this Certificate.

On behalf of the British Board of Agrément

Date of Sixth issue: 19 June 2020

Originally certificated on 13 May 2011

Hardy Giesler
Chief Executive Officer



The BBA is a UKAS accredited certification body – Number 113.

The schedule of the current scope of accreditation for product certification is available in pdf format via the UKAS link on the BBA website at www.bbacerts.co.uk

Readers MUST check the validity and latest issue number of this Agrément Certificate by either referring to the BBA website or contacting the BBA directly.

Any photographs are for illustrative purposes only, do not constitute advice and should not be relied upon.

British Board of Agrément

Bucknalls Lane
Watford
Herts WD25 9BA

©2020

tel: 01923 665300
clientservices@bbacerts.co.uk
www.bbacerts.co.uk

In the opinion of the BBA, Termok8 Adhesively Bonded External Wall Insulation Render Systems, if installed, used and maintained in accordance with the provisions of this Certificate, can satisfy, or contribute to satisfying, the relevant requirements of the following Building Regulations (the presence of a UK map indicates that the subject is related to the Building Regulations in the region or regions of the UK depicted):



The Building Regulations 2010 (England and Wales) (as amended)

Requirement:	A1	Loading
Comment:		The systems can sustain and transmit wind loads to the substrate wall. See sections 7.1 to 7.12 of this Certificate.
Requirement:	B4(1)	External fire spread
Comment:		The systems are restricted by this Requirement. See sections 8.1 to 8.5 of this Certificate.
Requirement:	C2(b)	Resistance to moisture
Comment:		The systems provide a degree of protection against rain ingress. See section 10.1 of this Certificate.
Requirement:	C2(c)	Resistance to moisture
Comment:		The systems can contribute to minimising the risk of interstitial and surface condensation. See sections 11.1, 11.2 and 11.4 of this Certificate.
Requirement:	L1(a)(i)	Conservation of fuel and power
Comment:		The systems can contribute to satisfying this Requirement. See sections 6.2 and 6.3 of this Certificate.
Regulation:	7(1)	Materials and workmanship
Comment:		The systems are acceptable. See section 13.1 and the <i>Installation</i> part of this Certificate.
Regulation:	7(2)	Materials and workmanship
Comment:		The systems are restricted by this Regulation. See section 8.1 to 8.5 of this Certificate.
Regulation:	26	CO₂ emission rate for new buildings
Regulation:	26A	Fabric energy efficiency rates for new dwellings (applicable to England only)
Regulation:	26A	Primary energy consumption rates for new buildings (applicable to Wales only)
Regulation:	26B	Fabric performance values for new dwellings (applicable to Wales only)
Comment:		The systems can contribute to satisfying these Regulations. See sections 6.2 and 6.3 of this Certificate.



The Building (Scotland) Regulations 2004 (as amended)

Regulation:	8(1)(2)	Durability, workmanship and fitness of materials
Comment:		The systems can contribute to satisfying this Regulation. See sections 12 and 13.1 and the <i>Installation</i> part of this Certificate.
Regulation:	9	Building standards applicable to construction
Standard:	1.1	Structure
Comment:		The systems can sustain and transmit wind loads to the substrate wall. See sections 7.1 to 7.12 of this Certificate.
Standard:	2.6	Spread to neighbouring buildings
Comment:		The systems are restricted by this Standard, with reference to clauses 2.6.4 ⁽¹⁾⁽²⁾ , 2.6.5 ⁽¹⁾ and 2.6.6 ⁽²⁾ . See sections 8.1 to 8.4, 8.6 and 8.7 of this Certificate.

Standard:	2.7	Spread on external walls
Comment:		The systems are restricted by this Standard, and are acceptable for use more than one metre from a boundary, with reference to clauses 2.7.1 ⁽¹⁾⁽²⁾ and 2.7.2 ⁽²⁾ , and Annex 2B ⁽¹⁾ . See sections 8.1 to 8.4, 8.6 and 8.7 of this Certificate.
Standard:	3.10	Precipitation
Comment:		The systems can contribute to satisfying this Standard, with reference to clauses 3.10.1 ⁽¹⁾⁽²⁾ and 3.10.2 ⁽¹⁾⁽²⁾ . See section 10.1 of this Certificate.
Standard:	3.15	Condensation
Comment:		The systems can contribute to satisfying this Standard, with reference to clauses 3.15.1 ⁽¹⁾⁽²⁾ , 3.15.4 ⁽¹⁾⁽²⁾ and 3.15.5 ⁽¹⁾⁽²⁾ . See sections 11.3 and 11.4 of this Certificate.
Standard:	6.1(b)	Carbon dioxide emissions
Standard:	6.2	Buildings insulation envelope
Comment:		The systems can contribute to satisfying these Standards, with reference to clauses (or parts of) 6.1.1 ⁽¹⁾ , 6.1.2 ⁽¹⁾⁽²⁾ , 6.1.3 ⁽¹⁾⁽²⁾ , 6.1.6 ⁽¹⁾ , 6.1.10 ⁽²⁾ , 6.2.1 ⁽¹⁾⁽²⁾ , 6.2.3 ⁽¹⁾ , 6.2.4 ⁽²⁾ , 6.2.5 ⁽²⁾ , 6.2.6 ⁽¹⁾ , 6.2.7 ⁽¹⁾ , 6.2.8 ⁽²⁾ , 6.2.9 ⁽¹⁾⁽²⁾ , 6.2.10 ⁽¹⁾ , 6.2.11 ⁽¹⁾ , 6.2.12 ⁽²⁾ , and 6.2.13 ⁽¹⁾⁽²⁾ . See sections 6.2 and 6.3 of this Certificate.
Standard:	7.1(a)(b)	Statement of sustainability
Comment:		The systems can contribute to satisfying the relevant requirements of Regulation 9, Standards 1 to 6, and therefore will contribute to a construction meeting the bronze level of sustainability as defined in this Standard. In addition, the systems can contribute to a construction meeting a higher level of sustainability as defined in this Standard with reference to clauses 7.1.4 ⁽¹⁾⁽²⁾ [Aspect 1 ⁽¹⁾⁽²⁾ and 2 ⁽¹⁾], 7.1.6 ⁽¹⁾⁽²⁾ [Aspect 1 ⁽¹⁾⁽²⁾ and 2 ⁽¹⁾] and 7.1.7 ⁽¹⁾⁽²⁾ [Aspect 1 ⁽¹⁾⁽²⁾]. See section 6.2 of this Certificate.
Regulation:	12	Building standards applicable to conversions
Comment:		All comments given for the systems under Regulation 9, Standards 1 to 6, also apply to this Regulation, with reference to clause 0.12.1 ⁽¹⁾⁽²⁾ and Schedule 6 ⁽¹⁾⁽²⁾ .
		(1) Technical Handbook (Domestic). (2) Technical Handbook (Non-Domestic).



The Building Regulations (Northern Ireland) 2012 (as amended)

Regulation:	23	Fitness of materials and workmanship
Comment:		The systems are acceptable. See section 13.1 and the <i>Installation</i> part of this Certificate.
Regulation:	28(b)	Resistance to moisture and weather
Comment:		Walls insulated with the systems can satisfy this Regulation. See section 10.1 of this Certificate.
Regulation:	29	Condensation
Comment:		Walls insulated with the systems can satisfy the requirements of this Regulation. See section 11.4 of this Certificate.
Regulation:	30	Stability
Comment:		The systems can sustain and transmit wind loads to the substrate wall. See sections 7.1 to 7.12 of this Certificate.
Regulation:	36(a)	External fire spread
Comment:		The systems are restricted by this Regulation. See sections 8.1 to 8.5 of this Certificate.
Regulation:	39(a)(i)	Conservation measures
Regulation:	40	Target carbon dioxide emission rate
Comment:		The systems can contribute to satisfying this Regulation. See sections 6.2 and 6.3 of this Certificate.

Construction (Design and Management) Regulations 2015

Construction (Design and Management) Regulations (Northern Ireland) 2016

Information in this Certificate may assist the client, designer (including Principal Designer) and contractor (including Principal Contractor) to address their obligations under these Regulations.

See sections: 3 *Delivery and site handling* (3.2 and 3.4) and 12 *Maintenance and repair* of this Certificate.

Additional Information

NHBC Standards 2020

In the opinion of the BBA, TermoK8 Adhesively Bonded External Wall Insulation Render Systems, if installed, used and maintained in accordance with this Certificate, can satisfy or contribute to satisfying the relevant requirements in relation to *NHBC Standards*⁽¹⁾, *Part 6 Superstructure (excluding roofs)*, Chapter 6.9 *Curtain walling and cladding*.

(1) There is a general requirement in *NHBC Standards*, Chapter 6.9, for fire-retardant-treated EPS insulation to be used with these systems in accordance with BS EN 13163 : 2012.

Technical Specification

1 Description

1.1 TermoK8 Adhesively Bonded External Wall Insulation Render Systems comprise expanded polystyrene (EPS) (standard white or enhanced grey) or phenolic foam (PF) or polyisocyanurate (PIR) insulation boards which are primarily bonded to the external surface of the wall with a minimum of 40% coverage of adhesive, supplementary mechanical fixings applied through the insulation boards whilst the adhesive is setting. Basecoat is applied to the surface of the boards to a uniform 3 mm thickness, with the reinforcing mesh immediately embedded and the surface smoothed with a trowel. A further layer of 3 mm basecoat render is applied over the mesh to achieve the required overall minimum thickness. When the basecoat is dry, the selected finishes are applied, (see Figure 1).

Table 1 TermoK8 Adhesively Bonded External Wall Insulation Render Systems – summary

Components	Product	
	Option 1	Option 2
Adhesive	Klebocem/Klebocem Minerale Klebocem Adefix 12	Klebocem Grosso Klebocem Adefix 12
Insulations	EPS (white or grey), PF, PIR	EPS (white or grey), PIR ⁽¹⁾
Basecoat	Klebocem Klebocem Minerale Klebocem Adefix 12	Klebocem Grosso Klebocem Adefix 12
Reinforcement	Armatex C1	Armatex C1/TermoK8 lath profile mesh ⁽²⁾
Top coats	—	Brick effect base render Dash receiver Acrylic brick-slips adhesive GlueFlex Ultra bedding mortar
Finishes and/or decorative profiles	TermoK8 Rivatone Plus TermoK8 Rivatone Idrosiliconico Plus TermoK8 Rivatone Plus TRV	Brick effect render top Spar dry-dash aggregate Acrylic brick-slip Brick-slip + Grout joint mortar

(1) This insulation can only be used with the brick effect base and brick effect top render system.

(2) TermoK8 lath profile mesh — used only with clay brick-slips.

1.2 The systems comprise the following components:

Insulation⁽¹⁾

- grey expanded polystyrene (EPS 70) 0.32 — 1200 by 600 mm grey insulation boards in a range of thicknesses from 30⁽²⁾ to 300 mm, with a nominal density of 20 kg·m⁻³, minimum compressive strength of 70 kN·m⁻² and tensile strength perpendicular to the faces of 150 kN·m⁻². Boards are manufactured to comply with the requirements of BS EN 13163 : 2012
- white expanded polystyrene (EPS 70) 0.38 — 1200 by 600 mm white insulation boards in a range of thicknesses from 30⁽²⁾ to 300 mm, with a nominal density of 20 kg·m⁻³, minimum compressive strength of 70 kN·m⁻² and tensile strength perpendicular to the faces of 150 kN·m⁻². Boards are manufactured to comply with the requirements of BS EN 13163 : 2012
- phenolic foam (PF) insulation boards — 1200 by 600 mm, in a range of thicknesses from 20⁽²⁾ to 200 mm, faced on both sides with a 0.3 mm layer of glass fibre, with a nominal density of 35 kg·m⁻³, minimum compressive strength of 120 kN·m⁻² and tensile strength perpendicular to the faces of 50 kN·m⁻². Boards are manufactured to comply with the requirements of BS EN 13166 : 2012
- polyisocyanurate (PIR) tissue-faced insulation boards — 1200 by 600 mm, in a range of thicknesses from 50⁽²⁾ to 150 mm, with a nominal density of 40 kg·m⁻³, minimum compressive strength of 120 kN·m⁻², and a tensile strength perpendicular to the faces of 80 kN·m⁻². The boards are manufactured to comply with the requirements of BS EN 13165 : 2012

(1) For the declared thermal conductivity values (λ D), see Table 3.

(2) Insulation thicknesses of 20, 30 and 40 mm would generally be used in reveals for EPS (up to 50 mm for PF and PIR).

Adhesives

- Klebocem, Klebocem Minerale, Klebocem Grosso and Klebocem Adefix 12 — grey or white cement-based powders with particle sizes of 0.6 mm (Klebocem, Klebocem Minerale and Klebocem Adefix 12) or 1.2 mm (Klebocem Grosso), organic content 3.1%, mixed with approximately 24% water by volume to form a paste. Applied at a coverage of 9 kg·m⁻² to give a finished thickness of 5 to 7 mm and used to fix the insulation boards to the substrate (see section 16.6)

Mechanical fixings (supplementary)

- TermoK8 fixings — a range of anchorage plugs⁽¹⁾, with an anchorage depth of a least 25 mm, approved and supplied by the Certificate holder selected from:
 - C1-CS — high-density polyethylene (HDPE) anchor sleeve with a metal centre pin
 - C1-CF — HDPE hammer-in anchor plugs with grip flanges and a metal centre pin
 - CT — HDPE anchor sleeve with metal centre pin
 - Ejotharm STR U — HDPE anchor sleeve and polystyrene anchor cap with galvanized steel centre pin
 - Ejotharm NT U — HDPE anchor sleeve with galvanized steel centre pin
 - Ejot H1 Eco — HDPE anchor sleeve and PA fixing mounting plug with galvanized steel centre pin

(1) Other fixings may be used provided they can be demonstrated to have equal or higher pull-out, plate diameter, plate stiffness and material characteristics.

Basecoats

- Klebocem, Klebocem Minerale and Klebocem Adefix 12 — grey or white cement-based powders with a particle size of 0.6 mm, mixed with approximately 24% water by volume to form a paste, with a coverage rate of approximately 2.5 to 3.5 kg·m⁻². Applied to a minimum thickness of 6 mm
- Klebocem Grosso — grey or white cement-based powders with a particle size of 1.2 mm, mixed with approximately 5 litres of clean water per 25 kg bag to form a paste. Applied to a minimum thickness of 6 mm

Reinforcement

- Armatex C1 — woven alkali-resistant glass fibre reinforcing mesh, cell size approximately 3 by 3.5 mm, with a polymer coating and a nominal weight of 160 g·m⁻²

- Termok8 lath profile mesh — stainless steel reinforcing mesh profile, 2440 by 685 mm, with cell size approximately 9 by 9 mm, with a nominal weight of 1.15 kg·m⁻²

Primer

- acrylic primer — water-based single-component primer, supplied in liquid form for use with Termok8 Rivatone Plus
- silicone primer — water-based single-component primer, supplied in liquid form for use with Termok8 Rivatone Idrosiliconico Plus
- acrylic brick-slip primer — water-based single-component primer, supplied in liquid form, for use with acrylic brick-slips

Top coats

- brick effect base render — polymer-based powder containing cement, to which 4 to 5 litres of clean water is added. Applied at a coverage of 9 kg·m⁻², to give an approximate 6 mm thickness
- dash receiver — light-coloured top coat, comprising limestone sand conforming to BS EN 13139 : 2013, cement conforming to BS EN 197-1 : 2011 and additives. Supplied as a powder to which 4 to 5 litres of clean water is added, and applied at a coverage 9 kg·m⁻² to give a 5 mm thickness
- acrylic brick-slips adhesive — organic-bound, polymer dispersion water-based ready-to-use adhesive and joint mortar. Supplied pre-coloured in white, light grey and brown, and applied at a coverage of 9 kg·m⁻² to give a 2 mm thickness. For the application of the acrylic brick-slips
- GlueFlex Ultra bedding mortar — high-adhesive-strength cementitious-based mortar conforming to BS EN 12004 : 2007, cement conforming to BS EN 197-1 : 2011 and additives. Applied at a coverage of 9 kg·m⁻², to give a 3 to 5 mm thickness. For the application of the clay brick-slips

Finishes

- Termok8 Rivatone Plus — acrylic resin-based, ready-to-use granular paste with 1.5 mm particle size, and applied to a 1.5 to 3 mm thickness, with a coverage rate of approximately 2.5 to 3.5 kg·m⁻². Available in a range of colours
- Termok8 Rivatone Idrosiliconico Plus — silicone resin-based, ready-to-use granular paste with 1.2 mm particle size, and applied to a 1.2 to 3 mm thickness, with a coverage rate of approximately per 1.5 to 2.5 kg·m⁻². Available in a range of colours
- Brick effect render top — polymer-based powder containing cement, to which 4 to 5 litres of clean water is added. Applied at a coverage of 9 kg·m⁻² to give an approximate 2 to 6 mm thickness
- Termok8 Rivatone Plus TRV — silicone-enhanced acrylic resin-based, ready-to-use granular paste with 1, 1.2 and 1.5 mm particle sizes, and applied to a 1, 1.2 or 1.5 mm thickness, with a coverage rate of approximately 1.9 to 3 kg·m⁻². Available in a range of colours

Decorative profiles

- spar dry-dash aggregate — available in a range of colours to suit the dash receiver, with a 3 to 8 mm aggregate size
- acrylic brick-slip — 4 to 6 mm thick, 65 mm wide by 215 mm long, weather-resistant pre-coloured, acrylic brick-slips
- clay brick-slip — extruded or cut brick-slips in the following sizes: 6 to 14 mm thick, 65 mm wide by 215 mm long, and 8 to 20 mm thick, 55 mm wide by 250 mm long. Manufactured in accordance with BS EN 771-1 : 2011

Grout/pointing mortar

- grout/pointing mortar — pre-coloured water-repellent, frost-resistant, cementitious grouting mortar, in accordance with BS EN 13888 : 2009. Only to be used with the clay brick-slips.

Figure 1 TermoK8 Adhesively Bonded External Wall Insulation Render Systems

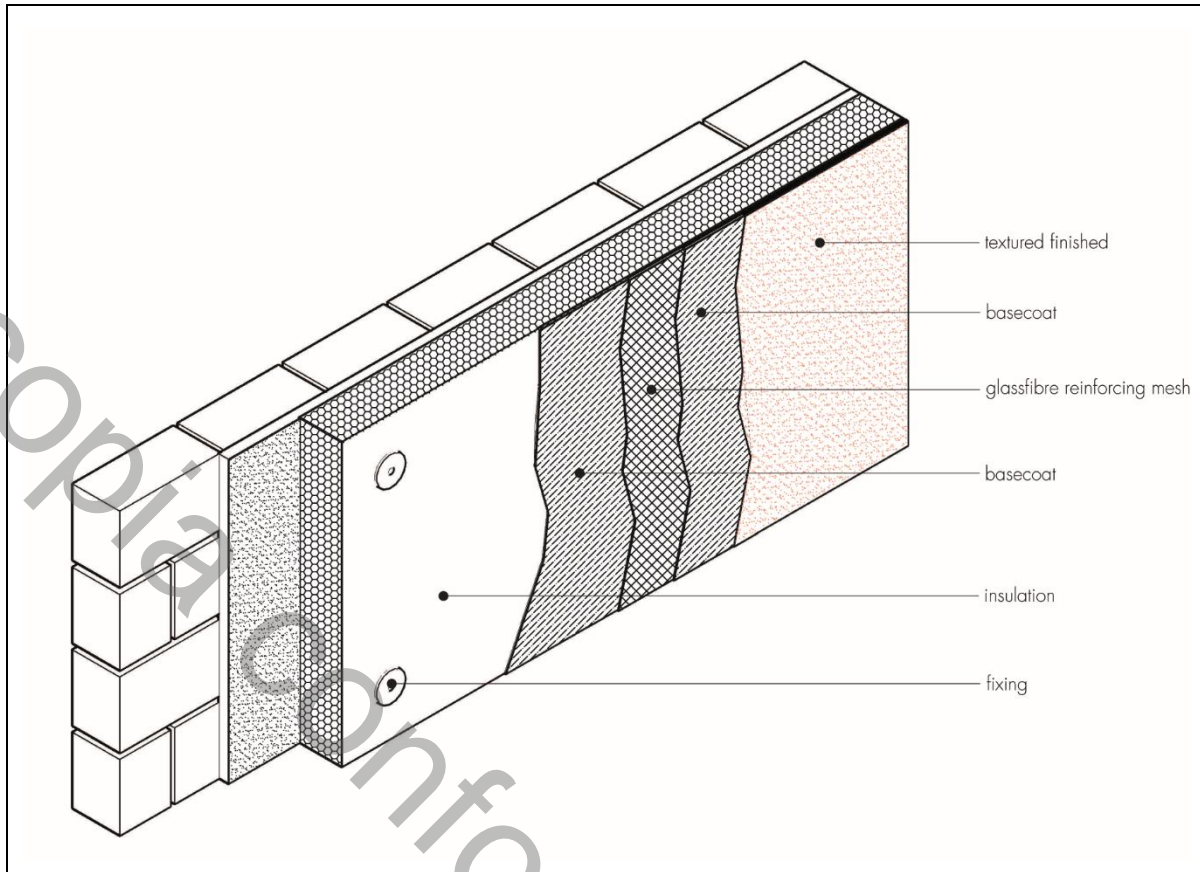

1.3 Ancillary materials also used with the systems include a range of aluminium, PVC-U or stainless steel profiles, comprising:

- base profile
- edge profile
- corner profile
- render stop profile
- movement and expansion joint
- profile connectors and fixings.

1.4 Ancillary materials also used with the systems but outside the scope of this Certificate include:

- fungicidal wash, water-based masonry cleaner and steriliser containing biocides
- expansion foam
- silicone or mastic silicone sealants in accordance with BS EN ISO 11600 : 2003
- mineral wool fire barrier
- cement or polymer-based mortar to repair the substrate surface.

2 Manufacture

2.1 The systems' components are manufactured by the Certificate holder or bought in from suppliers, to an agreed specification.

2.2 As part of the assessment and ongoing surveillance of product quality, the BBA has:

- agreed with the manufacturer the quality control procedures and product testing to be undertaken
- assessed and agreed the quality control operated over batches of incoming materials
- monitored the production process and verified that it is in accordance with the documented process
- evaluated the process for management of nonconformities
- checked that equipment has been properly tested and calibrated

- undertaken to carry out the above measures on a regular basis through a surveillance process, to verify that the specifications and quality control operated by the manufacturer are being maintained.

2.3 The systems are marketed in the UK by Aliva UK, 1210 Parkview, Arlington Business Park, Theale, Berkshire RG7 4TY, Tel: 01189 635 900, e-mail: enquiries@gruppovivas.co.uk

3 Delivery and site handling

3.1 The insulation is delivered to site shrink-wrapped in polythene packs bearing the manufacturer's and product identification marks and batch numbers.

3.2 The other system components are delivered to site in the packaging and quantities listed in Table 2. Each package carries the manufacturer's and product identification marks and batch numbers.

Table 2 Components — supply details⁽¹⁾

Component	Quantity/weight
Adhesive (grey or white)	25 kg bag
Klebocem basecoats	25 kg bag
Armatex C1 reinforcing mesh	1 m wide by 50 m length roll
TermoK8 lath profile reinforcing mesh	2440 by 685 mm sheet
TermoK8 Rivatone Plus	25 kg plastic tub
TermoK8 Rivatone Plus TRV	25 kg plastic tub
TermoK8 Rivatone Idrosiliconico Plus	25 kg plastic tub
Brick effect render top	25 kg bag
Brick effect render base	25 kg bag
Dash receiver	25 kg bag
Spar dash aggregate	25 kg bag
GlueFlex Ultra bedding mortar	5, 15 or 25 kg bags
Acrylic brick-slips adhesive	20 kg bucket
Acrylic brick-slips	200 per box
Grout/pointing mortar	25 kg bag
Clay brick-slips	60 per box

(1) Ancillary items, such as aluminium profiles or fixings, are supplied boxed as appropriate.

3.3 The boards must be stored on a firm, clean, level base, off the ground and under cover until required for use. Care must be taken when handling to avoid damage.

3.4 The boards must be protected from prolonged exposure to sunlight, either by storing opened packs under cover or re-covering with opaque polythene sheeting. Care must be taken to avoid contact with solvents or materials containing volatile organic components. The boards must not be exposed to open flame or other ignition sources.

3.5 The adhesive, basecoat and topcoats and all cementitious materials must be stored in dry conditions within 5 and 30°C, off the ground and protected from moisture. Contaminated material must be discarded.

Assessment and Technical Investigations

The following is a summary of the assessment and technical investigations carried out on TermoK8 Adhesively Bonded External Wall Insulation Render Systems.

Design Considerations

4 General

4.1 TermoK8 Adhesively Bonded External Wall Insulation Render Systems, when installed in accordance with this Certificate, are satisfactory for use in reducing the thermal transmittance (U value) of external masonry or concrete walls of new and existing buildings. It is essential that the detailing techniques specified in this Certificate are carried out to a high standard if the ingress of water into the insulation is to be avoided and the full thermal benefit obtained

from treatment with the systems (eg the insulation must be protected by an overhang, and window sills should be designed and installed so as to direct water away from the building).

4.2 For improved thermal/carbon-emissions performance of the structure, the designer should consider additional/alternative fabric and/or services measures.

4.3 The systems are for application to the outside of external walls of masonry, normal weight concrete, lightweight concrete, autoclaved concrete or no-fines concrete construction, on new or existing domestic and non-domestic buildings (with or without existing render) up to 18 metres in height in England, Wales and Northern Ireland, and with no storey more than 11 metres above the ground in Scotland. Prior to installation of the systems, wall surfaces should comply with section 14 of this Certificate.

4.4 New walls subject to national Building Regulations should be constructed in accordance with the relevant recommendations of:

- BS EN 1992-1-1 : 2004 and its UK National Annex
- BS EN 1996-1-1 : 2005 and its UK National Annex
- BS EN 1996-2 : 2006 and its UK National Annex
- BS 8000-0 : 2014
- BS 8000-2.2 : 1990
- BS 8000-3 : 2001.

4.5 New walls not subject to regulatory requirements should also be built in accordance with the Standards identified in section 4.4 of this Certificate.

4.6 Movement joints should be incorporated into the systems in line with existing movement joints in the building structure and in accordance with the Certificate holder's recommendations for the specific installation.

4.7 The systems will improve the weather resistance of a wall and provide a decorative finish. However, for existing buildings, they should only be installed where there are no signs of dampness on the inner surface of the wall other than those caused solely by condensation.

4.8 The effect of the systems on the acoustic performance of a construction is outside the scope of this Certificate.

4.9 The fixing of sanitary pipework, plumbing, rainwater goods, satellite dishes, clothes lines, hanging baskets and similar items to the systems is outside the scope of this Certificate, (see section 4.10).

4.10 External pipework and ducts should be removed before installation, and alterations made to underground drainage to accommodate repositioning of the pipework to the finished face of the systems. The Certificate holder can advise on suitable fixing methods, but these are outside the scope of this Certificate.

4.11 The designer should select a construction appropriate to the local wind-driven rain index, paying due regard to the design detailing, workmanship and materials to be used.

4.12 It is essential that the systems are installed and maintained in accordance with the conditions set out in this Certificate.

5 Practicability of installation

The systems should only be installed by specialist contractors who have successfully undergone training and registration by the Certificate holder (see section 15).

Note: The BBA operates a UKAS-accredited Approved Installer Scheme for external wall insulation; details of approved installer companies are included on the BBA's website (www.bbacerts.co.uk).

6 Thermal performance

6.1 Calculations of thermal transmittance (U value) should be carried out in accordance with BS EN ISO 6946 : 2017 and BRE Report BR 443 : 2006, using the declared thermal conductivity values (λ_D) of the insulations given in Table 3.

Table 3 Declared thermal conductivity values (λ_D) and available thicknesses

Insulation type	Thickness (mm)	Thermal conductivity ($\text{W}\cdot\text{m}^{-1}\cdot\text{K}^{-1}$)
White EPS 70	30 to 300	0.038
Grey EPS 70	30 to 300	0.032
PF	20 to 45	0.021
	45 to 200	0.020
PIR (glass tissue facing)	50 to 80	0.027
	80 to 120	0.026
	120 to 150	0.025



6.2 The U value of a completed wall will depend on the insulation type and thickness, fixing method and type and number of fixings, and the insulating value of the substrate masonry and its internal finish. Calculated U values for sample constructions in accordance with the national Building Regulations are given in Table 4, and are based on the thermal conductivities given in Table 3.

Table 4 Insulation thickness required to achieve design U values⁽¹⁾⁽²⁾⁽³⁾

U value ($\text{W}\cdot\text{m}^{-2}\cdot\text{K}^{-1}$) ⁽⁴⁾	Thickness of insulation (mm)							
	215 mm brickwork, $\lambda_D = 0.56 \text{ W}\cdot\text{m}^{-1}\cdot\text{K}^{-1}$				200 mm dense blockwork, $\lambda_D = 1.75 \text{ W}\cdot\text{m}^{-1}\cdot\text{K}^{-1}$			
	White EPS 70	Grey EPS	PF	PIR	White EPS 70	Grey EPS	PF	PIR
0.18	200	170	105	130	210	180	115	140
0.19	190	160	105	120	200	170	105	130
0.25	140	120	75	100	150	120	75	100
0.26	130	110	75	90	140	120	75	100
0.28	120	100	65	80	130	110	65	90
0.30	110	90	55	80	120	100	65	80
0.35	90	80	55	70	100	80	55	70

- (1) Wall construction inclusive of 13 mm plaster ($\lambda = 0.57 \text{ W}\cdot\text{m}^{-1}\cdot\text{K}^{-1}$), brickwork (protected) with 17.1% mortar or dense blockwork with 6.7% mortar ($\lambda = 0.88 \text{ W}\cdot\text{m}^{-1}\cdot\text{K}^{-1}$). A 5 mm thick adhesive layer with $\lambda = 1$ covering 40% of the area is also included, and a board emissivity of 0.9, together with an external render thickness of 7.2 mm with $\lambda = 1 \text{ W}\cdot\text{m}^{-1}\cdot\text{K}^{-1}$.
- (2) Calculations based on a system that included 4 galvanized steel fixings per square metre with a point thermal transmittance (X_p) of $0.002 \text{ W}\cdot\text{m}^{-1}\cdot\text{K}^{-1}$ per steel pin. Use of other types of fixings should be calculated in accordance with BS EN ISO 6946 : 2017. A gap correction (DU) of zero is assumed.
- (3) Based upon incremental insulation thickness of 10 mm.
- (4) When applying the maximum available insulation thickness, these walls can achieve U values from 0.10 to $0.16 \text{ W}\cdot\text{m}^{-2}\cdot\text{K}^{-1}$ depending on insulation and wall type.

6.3 Care must be taken in the overall design and construction of junctions with other elements and openings to minimise thermal bridges and air infiltration. Detailed guidance can be found in the documents supporting the national Building Regulations.

7 Strength and stability

General



7.1 The Certificate holder is ultimately responsible for the design of the systems and it is the responsibility of the company installing the systems to accurately follow the installation instructions (see also section 5). The Certificate holder must also verify that a suitably experienced and qualified individual (with adequate professional indemnity) establishes that:

- the wind loads on the different zones of the building's elevation for the specific geographical location have been calculated correctly (see section 7.3)
- the systems can adequately resist and safely transfer the calculated loads, accounting for all possible failure modes, to the substrate wall and supporting structure (see sections 7.3 to 7.6).

7.2 The substrate and supporting structure must be capable of transferring all additional loading due to the installation of the systems to the ground in a satisfactory manner. The adequacy of the substrate and supporting structure must be verified by the person or party responsible for the global stability of the building to which the systems are applied. Any defects should be made good prior to the systems being installed.

7.3 The wind loads on the walls should be calculated, taking into account all relevant factors such as location and topography, in accordance with BS EN 1991-1-4 : 2005 and its UK National Annex. All of the factors affecting wind load on each elevation and specific zones of the building must be considered. In accordance with BS EN 1990 : 2002 and its UK National Annex, a partial factor of 1.5 must be applied to the calculated characteristic wind pressure values to establish the design wind load to be resisted by the systems.

7.4 Installations correctly designed in accordance with this Certificate will safely accommodate the applied loads due to the self-weight of the systems, wind and impact.

7.5 Positive wind load is transferred to the substrate wall directly via compression through the render and insulation system.

7.6 Negative wind load is transferred to the substrate wall via⁽¹⁾⁽²⁾:

- the bond between the insulation and render system (see section 7.7)
- the tensile strength of the insulation (see section 7.8)
- the bond between the adhesive and the insulation interface⁽³⁾ (see section 7.9)
- the bond between the substrate and adhesive interface⁽³⁾ (see section 7.10).

(1) For adhesively fixed systems with supplementary mechanical fixings, the contribution of the fixings is not considered when calculating resistance to wind load.

(2) Further guidance is available from BBA Guidance Note 1, available on the BBA website (www.bbacerts.co.uk).

(3) The percentage of adhesive coverage should be considered.

7.7 The characteristic bond resistance between the insulation and render interface derived from test results was $100 \text{ kN}\cdot\text{m}^{-2}$ for EPS, $31 \text{ kN}\cdot\text{m}^{-2}$ for PF and $75 \text{ kN}\cdot\text{m}^{-2}$ for PIR insulations. The design resistance of the bond between the insulation and render (N_{RD1}) should be taken as the characteristic bond resistance divided by a partial factor of 9.

7.8 The characteristic tensile resistance of the insulation material may be taken as $100 \text{ kN}\cdot\text{m}^{-2}$ for EPS, $50 \text{ kN}\cdot\text{m}^{-2}$ for PF and $80 \text{ kN}\cdot\text{m}^{-2}$ for PIR insulations and should be divided by a partial material factor of 2.5 to establish the ultimate design resistance of the insulation ($R_{d,ins}$).

7.9 The characteristic bond resistance between the adhesive and the insulation derived from test results was $80 \text{ kN}\cdot\text{m}^{-2(1)}$. The design resistance of the bond between the adhesive and insulation (N_{RD2}) should be taken as this value divided by a partial factor of 9.

(1) The minimum bonded surface area (A_{min}) should not be less than 40%.

7.10 The characteristic bond resistance between the substrate and the adhesive derived from test results was $80 \text{ kN}\cdot\text{m}^{-2(1)(2)(3)}$. The design resistance of the bond between the substrate and the adhesive (N_{RD3}) should be taken as the characteristic resistance divided by a partial factor of 9.

(1) The bond between the substrate and the adhesive from the test should have a minimum failure resistance of $250 \text{ kN}\cdot\text{m}^{-2}$ after the adhesive has fully cured and in dry conditions, in accordance with ETAG 004 : 2013. The minimum failure resistance value is based on a minimum 28 day curing time of the test sample.

(2) The results from tests carried out on site for the bond between the substrate and the adhesive should be at least equal to $80 \text{ kN}\cdot\text{m}^{-2}$.

(3) The minimum bonded surface area (A_{min}) should not be less than 40%.

7.11 The number and spacing of the supplementary fixings should be determined by the Certificate holder. Provided the substrate wall is suitable and the supplementary fixings are covered by an appropriate ETA, the fixings will initially transfer the weight of the insulation system to the substrate wall while the adhesive is curing. However, since the characteristic pull-out resistance values are dependent on the substrate type, the fixing must be selected to suit the specific loads and substrate⁽¹⁾.

(1) To qualify as suitable data, the age and condition of the substrate must be equivalent to that used to establish the values in the ETA. If this not the case, site-specific pull-out tests must be carried out.

7.12 The data derived from sections 7.6 to 7.9 must be assessed against the design wind load and the following expression must be satisfied⁽¹⁾⁽²⁾:

For safe design:

$$R_d \geq W_e$$

$$R_{d,b,ins/rend} = A_r * N_{RD1}$$

$R_{d,t,ins}$ = characteristic tensile strength of insulation/2.5

$$R_{d,b,adh/ins} = A_{min} * N_{RD2}$$

$$R_{d,b,sub/adh} = A_{min} * N_{RD3}$$

Where:

R_d	is the design ultimate resistance ($kN \cdot m^{-2}$) taken as the minimum of $R_{d,b,ins/rend}$, $R_{d,t,ins}$, $R_{d,b,adh/ins}$ and $R_{d,b,sub/adh}$
W_e	is the maximum design wind load ($kN \cdot m^{-2}$)
$R_{d,b,ins/rend}$	is the bond design resistance between the insulation and render ($kN \cdot m^{-2}$)
A_r	is the reinforced basecoat bond area (based on % area covered)
N_{RD1}	is the design adhesive bond resistance between the insulation and render based on test ($kN \cdot m^{-2}$)
$R_{d,b,adh/ins}$	is the bond design resistance between the insulation and adhesive ($kN \cdot m^{-2}$)
A_{min}	is the minimum bonded surface area (based on % area covered)
N_{RD2}	is the design bond resistance between insulation and adhesive based on test ($kN \cdot m^{-2}$)
$R_{d,b,sub/adh}$	is the design bond resistance between the substrate and adhesive ($kN \cdot m^{-2}$)
N_{RD3}	is the design bond resistance between the substrate and adhesive based on test ($kN \cdot m^{-2}$).

(1) If the minimum design resistance (R_d) calculated in sections 7.6 to 7.9 is less than design wind pressure, the bonded surface area (A_{min}) should be increased.

(2) If the minimum bonded surface area required to resist the design wind load is higher than 100%, such systems would need to be mechanically fixed and therefore should not be installed: mechanically fixed system requirements are outside the scope of this Certificate.

Impact resistance

7.13 Hard body impact tests were carried out in accordance with ETAG 004 : 2013. The systems are suitable for use in the Use Categories up to and including those specified in Table 5 of this Certificate.

Table 5 System impact resistance

Render systems: Basecoat (+ primer + top coats/finishes/decorative profiles indicated below): For all installation types	Use Category ⁽¹⁾
Klebocem or Klebocem Minerale + TermoK8 Rivatone Plus or TermoK8 Rivatone Plus TRV	
Klebocem or Klebocem Minerale or Klebocem Adefix 12 + TermoK8 Rivatone Idrosiliconico Plus or Rivatone TRV	II
Klebocem Grosso + Brick effect render	III
Klebocem Grosso + Dash receiver + Spar dash aggregate	I
Klebocem Grosso + Acrylic brick-slips adhesive + Acrylic brick-slips	II
Klebocem Grosso + Clay brick-slips + Grout/pointing mortar	I

(1) The Use Categories are defined in ETAG 004 : 2013 as:

- Category I — a zone readily accessible at ground level to the public and vulnerable to hard body impacts but not subjected to abnormally rough use
- Category II — a zone liable to impacts from thrown or kicked objects, but in public locations where the height of the system will limit the size of the impact; or at lower levels where access to the building is primarily to those with some incentive to exercise care
- Category III — a zone not likely to be damaged by normal impacts caused by people or by thrown or kicked objects.

8 Behaviour in relation to fire



8.1 The reaction to fire classifications⁽¹⁾ of the systems in accordance with UNI EN 13501-1 : 2019 are given in Table 6 of this Certificate.

(1) Istituto Giordano S.p.A. 365208. A copy is available from the Certificate holder on request.

Table 6 Reaction to fire classifications

	Classification
Rendering system: Basecoat + top coats/finishes/decorative profiles indicated below	
Klebocem or Klebocem Minerale or Klebocem Adefix 12 + TermoK8 Rivatone Plus (using PF insulation)	B-s1, d0
Klebocem or Klebocem Minerale + TermoK8 Rivatone Idrosiliconico Plus (using PF insulation) or Rivatone Plus TRV	B-s1, d0
Klebocem or Klebocem Minerale + TermoK8 Rivatone Plus (using EPS insulation)	
Klebocem or Klebocem Minerale + TermoK8 Rivatone Idrosiliconico Plus (using EPS insulation)	
Klebocem Grosso + Brick effect render base + Brick effect render top	B-s2, d0
Klebocem Grosso + Dash receiver + Spar dash aggregates	B-s2, d0
Klebocem Grosso + Acrylic brick-slips adhesive + Acrylic brick-slips	B-s2, d0
Klebocem Grosso + GlueFlex Ultra bedding mortar + clay brick-slips + Grout joint mortar	B-s2, d0

8.2 The fire classifications apply to the full range of thicknesses and colours covered by this Certificate (when the organic content of the basecoat and finishing coat is a maximum of 3.1 and 9.4% respectively). The Certificate holder should be consulted to confirm the calorific value of a particular colour.

8.3 The insulations are not classified as 'non-combustible' or 'of limited combustibility'.

8.4 The classification of colours not satisfying the specification given in section 8.2 should be confirmed by reference to the documents supporting the national Building Regulations.



8.5 For all buildings in England, Wales and Northern Ireland, the systems are considered suitable for use on, or at any distance from, the boundary, and the systems are restricted for use in buildings up to 18 metres in height.



8.6 In Scotland, the systems are not classified as 'non-combustible' and may be used on buildings more than 1 m from a boundary and, on houses, 1 m or less from a boundary. With minor exceptions, the systems should be included in calculations of unprotected area, except on houses where the external wall behind has the appropriate fire resistance.

8.7 In Scotland, the systems should not be used on any building with a storey more than 11 m above the ground, or on any entertainment or assembly building with a total storey area more than 500 m², or on any hospital or residential care building with a total storey area more than 200 m².

8.8 For application to second storey walls and above, it is recommended that the designer considers at least one stainless steel fixing per square metre and fire barriers in line with compartment walls and floors, as advised in BRE Report BR 135 : 2013.

8.9 NHBC Standards require in all cases that a minimum of one non-combustible fixing through the reinforcement mesh, per square metre or per insulation board, whichever provides the greater number, should be provided, in addition to the other fixings.

8.10 Designers should refer to the relevant national Building Regulations and guidance for detailed conditions of use, particularly in respect of requirements for substrate fire performance, cavity barriers, service penetrations and combustibility limitations for other materials and components used in the overall wall construction.

Figure 2 Fire barrier

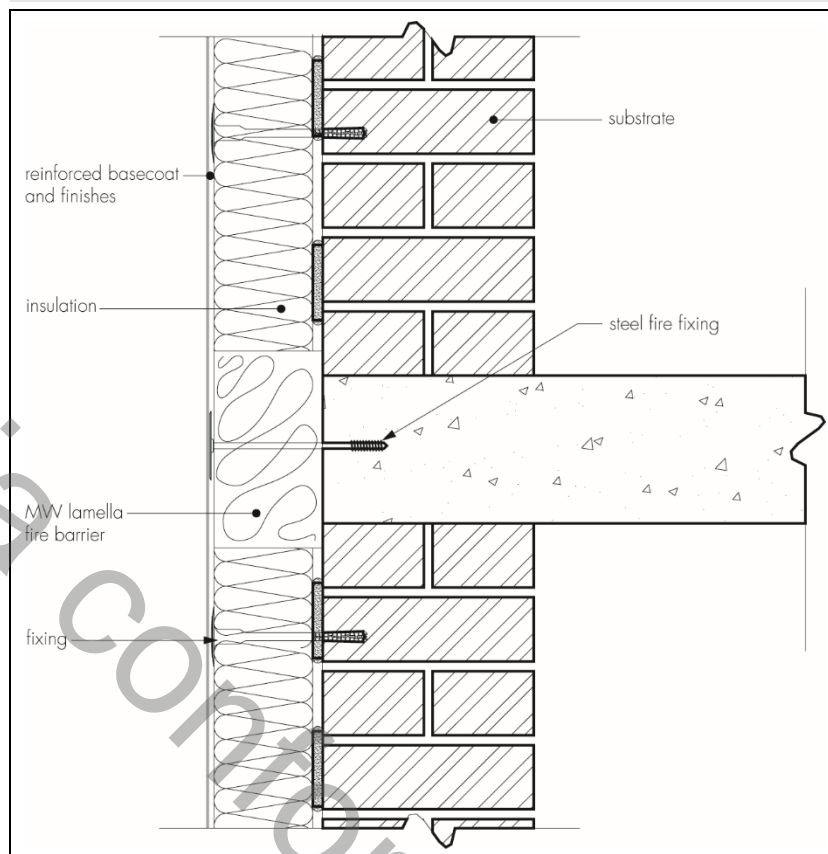

9 Proximity of flues and appliances

When the systems are installed in close proximity to certain flue pipes, the relevant provisions of the national Building Regulations should be satisfied:

England and Wales — Approved Document J

Scotland — Mandatory Standard 3.19, clause 3.19.4⁽¹⁾⁽²⁾

(1) Technical Handbook (Domestic).

(2) Technical Handbook (Non-Domestic).

Northern Ireland — Technical Booklet L.

10 Water resistance



10.1 The systems will provide a degree of protection against water ingress. However, care should be taken to ensure that walls are adequately watertight prior to application of the systems. The systems must only be installed where there is no sign of dampness on the inner surface of the substrate other than that caused solely by condensation.

10.2 Designers and installers should take particular care in detailing around openings, penetrations and movement joints to minimise the risk of water ingress.

10.3 The guidance given in BRE Report BR 262 : 2002 should be followed in connection with the watertightness of solid wall constructions. The designer should select a construction appropriate to the local wind-driven rain index, paying due regard to the design detailing, workmanship and materials to be used.

10.4 At the top of walls, the systems should be protected by an adequate overhang or other detail designed for use with these types of systems (see section 16).

11 Risk of condensation



11.1 Designers must ensure that an appropriate condensation risk analysis has been carried out for all parts of the construction, including openings and penetrations at junctions between the insulation system and windows, to minimise the risk of condensation. The recommendations of BS 5250 : 2011 should be followed.

Surface condensation



11.2 Walls will adequately limit the risk of surface condensation when the thermal transmittance (U value) does not exceed $0.7 \text{ W}\cdot\text{m}^{-2}\cdot\text{K}^{-1}$ at any point and the junctions with other elements and openings comply with section 6.3 of this Certificate.



11.3 Walls will adequately limit the risk of surface condensation when the thermal transmittance (U value) does not exceed $1.2 \text{ W}\cdot\text{m}^{-2}\cdot\text{K}^{-1}$ at any point. Guidance may be obtained from BS 5250 : 2011 Section 4 and Annex G, and BRE Report BR 262 : 2002.

Interstitial condensation



11.4 Walls incorporating the systems will adequately limit the risk of interstitial condensation when they are designed and constructed in accordance with BS 5250 : 2011, Section 4 and Annexes D and G.

11.5 The water vapour resistance factors (μ) (for the insulation boards) and equivalent air layer thicknesses (s_d) (for the render systems) are shown in Table 7.

Table 7 Water vapour resistance factors and equivalent air layer thicknesses

Layers	Thickness (mm)	s_d (m)	μ
white and grey EPS 70	30 to 300	–	20 to 40 ⁽¹⁾
PF	20 to 200	–	50
PIR	50 to 150	–	60
Rendering system:			
Basecoat + finish coat + decorative coat, as indicated below			
Klebocem + Termok8 Rivatone Plus	1.5 to 3	0.472	–
Termok8 Rivatone Idrosiliconico Plus	1.2 to 3	0.316	–
Rendering system:			
Klebocem Grosso basecoats	6 to 7	0.9	–
Brick effect render base + Brick effect render top	8 to 14	0.20	–
Dash receiver + Spar dash aggregate	9 to 14	1	–
GlueFlex Ultra bedding mortar	3 to 5	1.1	–
Clay brick-slips	6 to 14	0.30 to 0.75	50 to 37
Clay brick-slips	8 to 20	0.50 to 0.85	62.5 to 42.5
Grout/pointing joint mortar	6 to 14	– ⁽²⁾	– ⁽²⁾
Acrylic brick-slips adhesive + Acrylic brick-slips	6 to 8	0.19	–

(1) It is recommended that the lower figure is used when assessing the interstitial condensation risk.

(2) To be determined in each case.

12 Maintenance and repair



12.1 An initial inspection should be made within 12 months and regularly thereafter to include:

- visual inspection of the render for signs of damage. Cracks in the render exceeding 0.2 mm must be repaired
- examination of the sealant around openings and service entry points
- visual inspection of architectural details designed to shed water to confirm that they are performing properly

- visual inspection to ensure that water is not leaking from external downpipes or gutters; such leakage could penetrate the rendering
- necessary repairs effected immediately and the sealant joints at window and door frames replaced at regular intervals
- maintenance schedules, which should include the replacement and resealing of joints, for example between the insulation system and window and door frame.

12.2 Damaged areas must be repaired using the appropriate components and procedures detailed in the Certificate holder's installation instructions and in accordance with BS EN 13914-1 : 2016.

13 Durability



13.1 The systems will have a service life of at least 30 years provided any damage to the surface finish is repaired immediately and regular maintenance is undertaken, as described in section 12 of this Certificate.

13.2 Any render containing cement may be subject to lime bloom. The occurrence of this may be reduced by avoiding application in adverse weather conditions. The effect is transient and less noticeable on lighter colours.

13.3 The render may become discoloured with time, the rate depending on the initial colour, the degree of exposure and atmospheric pollution, as well as the design and detailing of the wall. In common with traditional renders, discoloration by algae and lichens may occur in wet areas. The appearance may be restored by a suitable power wash or, if required, by over coating.

13.4 To maintain a high quality aesthetic appearance, it may be necessary to periodically overcoat the building using a suitable masonry coating (ie one covered by a valid BBA Certificate for this purpose). Care should be taken not to adversely affect the water vapour transmission or fire characteristics of the systems. The advice of the Certificate holder should be sought as to the suitability of a particular product.

Installation

14 Site survey and preliminary work

14.1 A pre-installation survey of the property must be carried out to determine suitability for treatment and the need for any necessary repairs to the building structure before application of the systems. A specification is prepared for each elevation of the building indicating:

- additional corner mesh and reinforcement, where required
- the position of beads
- detailing around windows, doors and at eaves
- damp-proof course (dpc) level (outside the scope of this Certificate)
- exact position of expansion joints, if required
- areas where flexible sealants must be used
- any alterations to external plumbing
- where required, the position of fire barriers
- any alterations to external plumbing.

14.2 The survey should include tests conducted on the walls of the building by the Certificate holder or their approved installers (see section 15) to determine the bond strength between the adhesive and the substrate, and be satisfied that the pull-out resistance of the proposed supplementary mechanical fixings from substrate is adequate. An assessment and recommendation should be made on the minimum bond strength and type and number of fixings required to withstand the building's expected wind loading based on calculations using the test site data in accordance with section 7.

14.3 All modifications, such as alterations to external plumbing and necessary repairs to the building structure, must be completed before installation of the systems commences.

14.4 Surfaces should be sound, clean, and free from loose material. The flatness of surfaces must be checked; this may be achieved using a straight-edge spanning the storey height. Any excessive irregularities, ie greater than 20 mm in one metre, must be made good prior to installation, to ensure that the insulation boards are installed with a smooth, in-plane finished surface.

14.5 Where surfaces are covered with an existing render, it is essential that the bond between the background and the render is adequate. All loose areas should be hacked off and reinstated.

14.6 On existing buildings, purpose-made sills must be fitted to extend beyond the finished face of the systems. New buildings should incorporate suitably deep sills.

14.7 In new buildings, internal wet work, (eg screed or plastering) should be completed and allowed to dry prior to the application of a system.

15 Approved installers

Application of the systems, within the context of this Certificate, must be carried out by installers approved, recommended or recognised by the Certificate holder. Such an installer is a company:

- employing operatives who have been trained and approved by the Certificate holder to install the systems
- which has undertaken to comply with the Certificate holder's application procedure, containing the requirement for each application team to include at least one member-operative trained by the Certificate holder
- subject to at least one inspection per annum by the Certificate holder to ensure suitable site practices are being employed. This may include unannounced site inspections.

16 Procedure

General

16.1 Installation of the systems should be carried out in accordance with the Certificate holder's current installation instructions and this Certificate.

16.2 Weather conditions should be monitored to ensure correct application and curing conditions. Installation should not take place during rainfall or if rain is anticipated. Application of the coating materials must not be carried out at temperatures below 5 or above 35°C, or if exposure to frost is likely. The coating must be protected from rapid drying. In addition, cementitious-based renders must not be applied if the temperature will fall below 0°C within 72 hours of completion.

16.3 All rendering should be in accordance with the relevant recommendations of BS EN 13914-1 : 2016.

Positioning and securing insulation boards

16.4 The supporting base profile is secured to the external wall above the dpc using approved profile fixings at 400 mm maximum centres (see Figure 3). Base rail connectors are inserted at all rail joints. Extension profiles should be fixed to the front lip of the base rail or stop end channel where appropriate.

Figure 3 Typical section of base profile

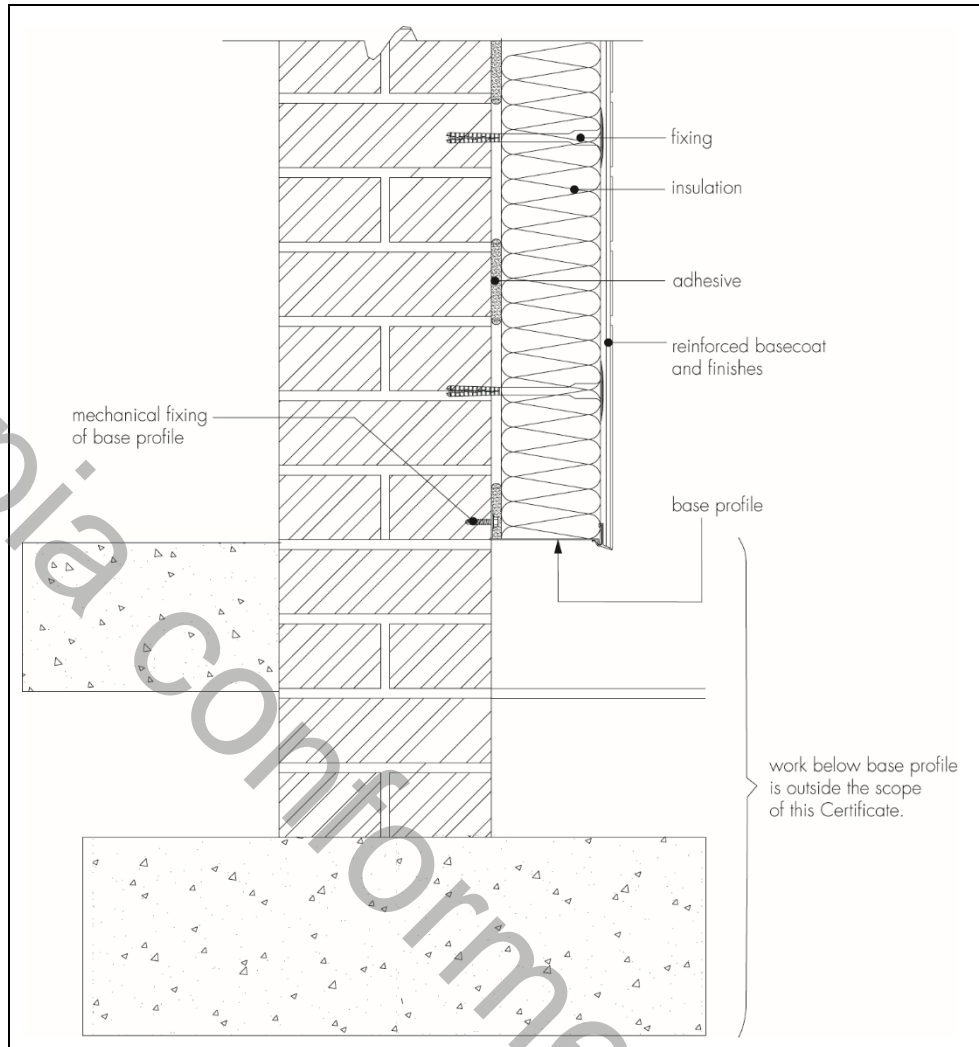

16.5 The adhesive is prepared with the required amount of water (see section 1), and mixed with a paddle mixer until the desired consistency is achieved. After allowing the adhesive to rest for 5 minutes, it is applied in a continuous bordering strip around the perimeter of the board with three additional dabs approximately 10 to 40 mm wide distributed uniformly over the remaining surface. Alternatively, a serrated edge trowel with 5 mm serrations can be used to apply the adhesive to the entire rear surface of the insulation board (see Figure 4). The adhesive should cover at least 40% of the board.

Figure 4 Insulation boards — adhesive pattern

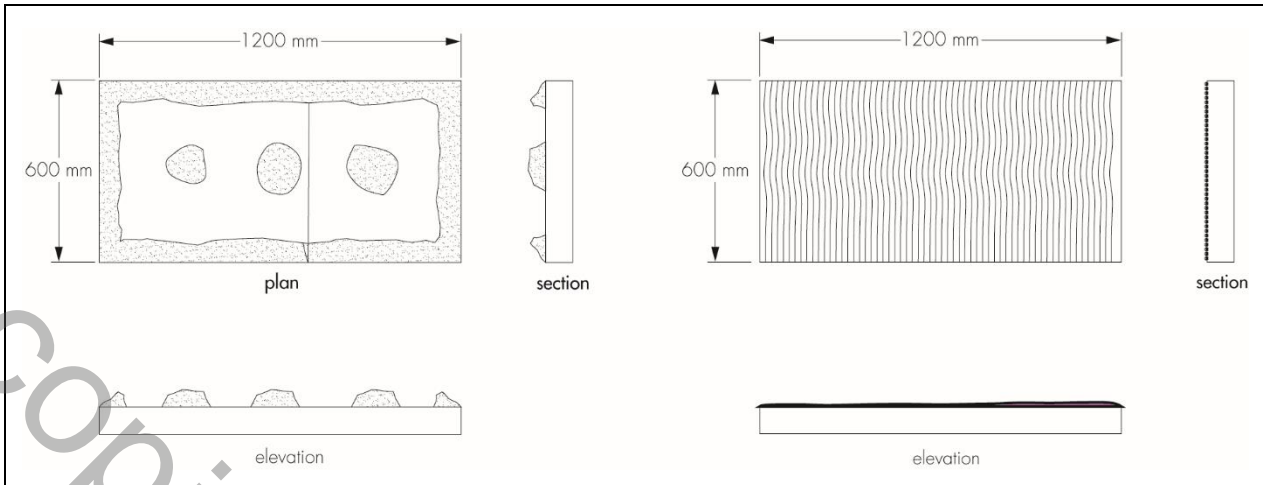

16.6 The first run of insulation boards is positioned on the base profile with the adhesive applied. The boards must be pressed firmly against the wall and butted tightly together and aligned to achieve a level finish. Subsequent rows of boards are positioned so that the vertical board joints are staggered and overlapped at the building corners and so that the board joints do not occur within 200 mm of the corners of openings (see Figure 5). Between boards, joints greater than 2 mm should be filled with slivers of insulation board or low-density polyurethane foam. Gaps greater than 10 mm should be closed by repositioning or, where appropriate, by cutting boards to fit. Any high spots or irregularities should be removed. Alignment should be checked as work proceeds.

Figure 5 Typical arrangement of insulation boards

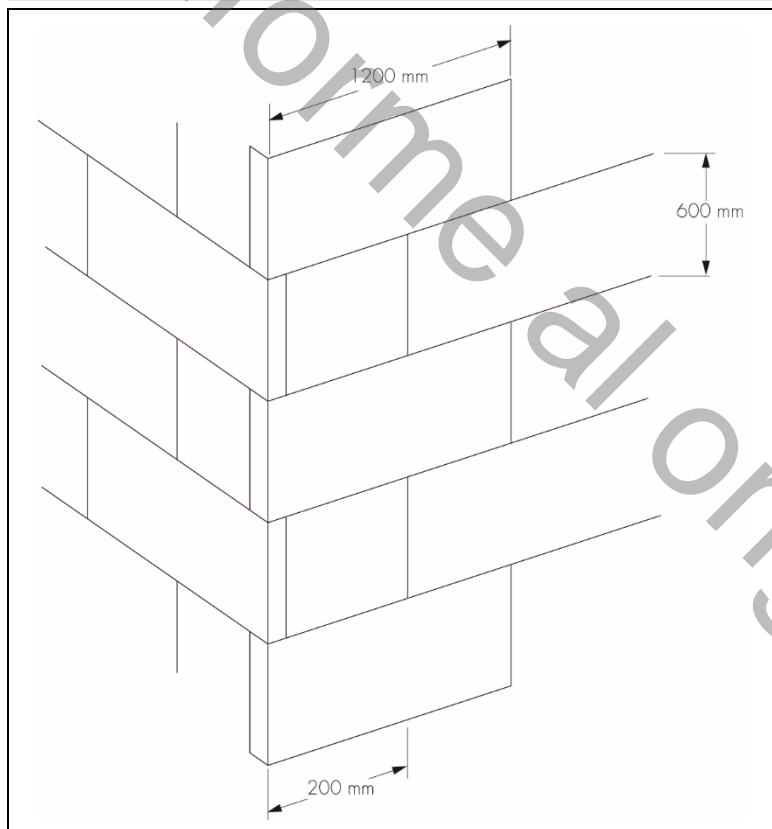

16.7 A minimum of three supplementary mechanical fixings per board in a 'saltire' fixing pattern (equivalent to four fixings per m²) are applied through the insulation board into the substrate wall to prevent the boards from collapsing or moving while the adhesive sets, but appropriate structural calculation should be undertaken by a competent person.

16.8 To fit around details such as doors and windows, insulation boards may be cut with a sharp knife or a fine-toothed saw. If required, purpose-made window sills designed to prevent water ingress and incorporating drips to shed water clear of the systems are fitted at this stage.

16.9 Installation continues until the whole wall is completely covered including, where appropriate, the building soffits. Periodic checks should be carried out as work proceeds.

16.10 Window and door reveals should be insulated to minimise the effects of cold bridging. Where clearance is limited, strips of approved insulation should be installed to suit available margins and details.

Movement joints

16.11 Generally, movement joints are not required in the systems but, if an expansion joint is already incorporated in the substrate, a movement joint must be included (see Figure 6). Specific types of joint have not been assessed as part of the systems and advice should be sought from the Certificate holder.

Figure 6 Typical movement joint

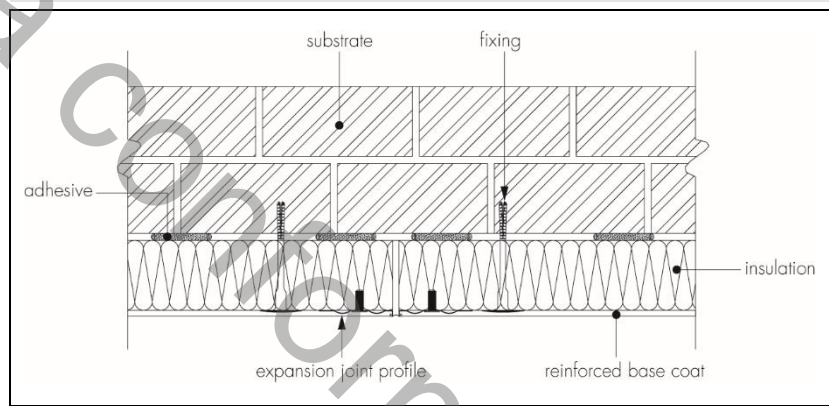

Application of basecoat and reinforcement mesh

16.12 Prior to the application of the basecoat render, a bead of joint sealant is gun-applied at window and door frames, overhanging eaves, gas and electric meter boxes, and wall vents, or where the render abuts any other building material or surface. Pieces of reinforcing mesh (approximate size 350 by 250 mm) should be used diagonally at the corners of windows and doors and other building openings so that they extend equally either side of the corner (see Figure 7).

Figure 7 Reinforcement at openings

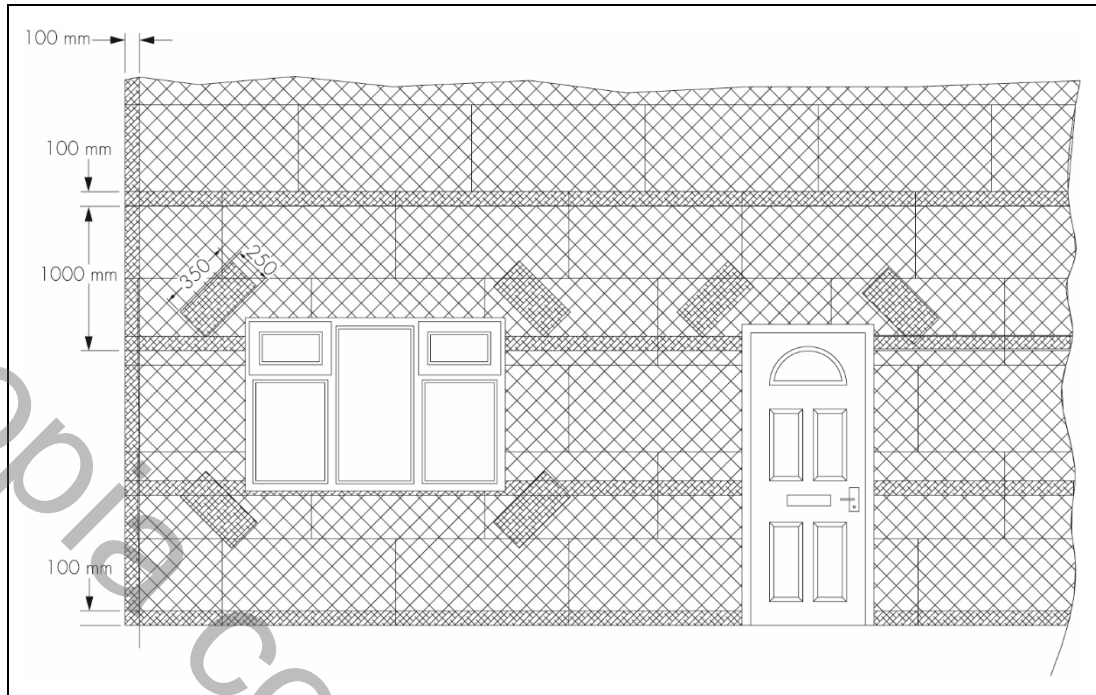

16.13 The basecoat is prepared with the required amount of water (see section 1) then applied over the insulation boards using a stainless steel trowel, and floated with a Darby float to an approximate 3 mm thickness. The reinforcing mesh is applied and immediately embedded into the basecoat by trowelling from the centre to the edge and an additional light coat of basecoat is applied (whilst the first coat is still wet) to ensure the mesh is free of wrinkles; overlapping at all mesh joints should not be less than 100 mm. The first basecoat is allowed to cure.

16.14 Further basecoat is then applied as required, to ensure the mesh is completely covered and the required minimum 6 mm thickness of basecoat is achieved.

16.15 The basecoat is applied progressively, working in one-metre sections in a vertical or horizontal direction.

16.16 Once the application of the basecoat is completed, it is left to dry. The drying time will depend upon the weather, but a minimum of 48 hours should elapse before the primer is applied (if required).

16.17 The primed basecoat should be dry for a least 24 hours before application of the top or finishes coats.

16.18 Stop beads are positioned vertically, eg at party wall positions where the adjoining house does not require treatment. Where required, angle beads are fixed to all building corners and to door and window heads and jambs.

Finishes

16.19 The finish coating must be trowel- or roller-applied to give the appropriate texture effect and applied to the required thicknesses (see section 1), using a stainless steel trowel and finished with a plastic trowel. The drying time is dependent on conditions, but will typically be 48 hours in accordance with the Certificate holder's instructions.

16.20 To prevent the finish from drying too rapidly, it should not be applied in direct sunlight. The finished render surface must be protected from rain and frost until the material is dry. Continuous surfaces must be completed without a break, eg working to a wet edge.

Top coats and decorative profiles

Dash receiver and spar aggregates

16.21 The dash receiver is prepared by mixing each 25 kg bag with 4.5 to 5 litres of clean water. The product is mixed thoroughly to the specified consistency and applied to a depth of 5 mm to achieve an even coat, using straight edges

and spatulas if necessary. A thicker coat of dash receiver may be necessary when using larger aggregates to ensure they fully bed into the dash receiver. While the receiver is still soft, selected clean spar aggregates are applied onto the surface.

16.22 Aggregates should be cleaned and dampened before dashing onto the dash receiver.

16.23 On completion, the surface must be checked to ensure an even coverage of the spar dash has been achieved. Where necessary, the aggregate should be lightly tamped to ensure that a good bond is achieved.

Brick-effect base render and top coat

16.24 The brick-effect render base is prepared with 4 to 5 litres of clean water, mixing thoroughly with an electric paddle mixer to the specified consistency for a minimum of 5 minutes, to disperse the additives.

16.25 The base layer should be applied to the surface of the basecoat using a hawk and trowel or render projection machine to a minimum thickness of 6 mm and ruled off to a flat finish.

16.26 After the base layer has started to stiffen, a second layer of brick-effect render top is applied to the brick-effect base render, following its initial stiffening to an average thickness of 3 to 6 mm, using a hawk and trowel, or render projection machine.

16.27 The brick effect top render pattern is achieved using various tamping blocks or stiff brushes, cutting out to the required pattern using an appropriate bespoke cutting tool, after the top layer has been shaded and textured. This reproduces recessed mortar coursing of the brickwork as required.

16.28 Following further stiffening of the materials, any face material left by the cutting out should be lightly brushed and removed using a soft bristled brush, allowing it to thoroughly dry out for 48 hours to one week depending on weather conditions.

Clay brick-slips

16.29 Clay brick-slip adhesive is applied with a 3 to 5 mm notched trowel to the entire surface of the primed basecoat, in workable sections.

16.30 The brick-slips are applied by hand in a brick bond fashion, lined and levelled into adhesive.

16.31 Joints are normally 10 mm wide, and are created using plastic spacers. The adhesive is left to cure before pointing the joints using grouting/pointing mortar which is applied using bag, gun or hand application. Once the pointing mortar has stiffened, it should be smoothed or struck using a suitable pointing tool. Brick-slips can be subject to shade variations and should, therefore, be selected at random from different boxes.

Acrylic brick-slips

16.32 Acrylic primer is applied by roller or brush. The primer is allowed to dry for at least 24 hours before application of the acrylic brick-slip adhesive, which is applied by a 5 mm notched trowel to the entire surface of the primed basecoat, in workable sections.

16.33 Acrylic brick-slips are applied by hand in a brick bond fashion, lined and levelled into adhesive. Joints are normally 10 mm wide and, when pointing, a suitably sized brush is used to smooth out the adhesive once it has stiffened into the joints. Acrylic brick-slips can be subject to shade variations and should, therefore, be selected at random from different boxes.

16.34 At the top of walls, the systems should be protected by an adequate overhang (see Figure 8) or by an adequately sealed purpose-made flashing. Care should be taken in the detailing of the systems around openings and projections (see Figures 9 to 11).

Figure 8 Typical roof eaves detail

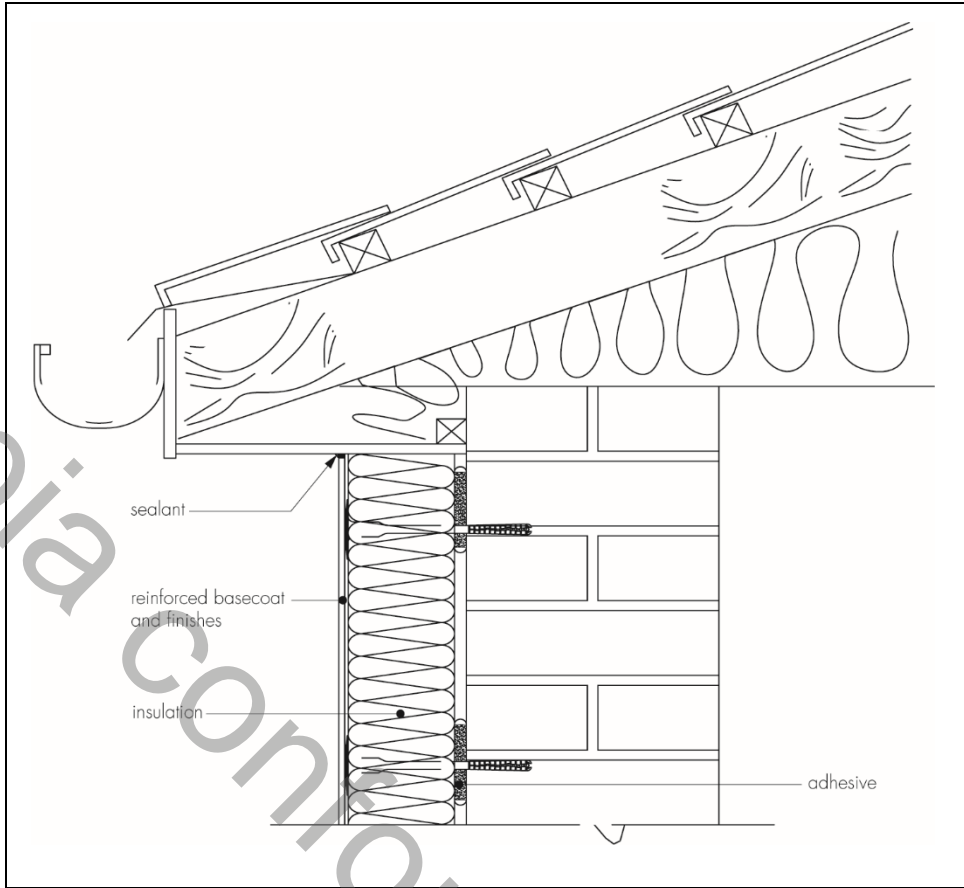

Figure 9 Window head details

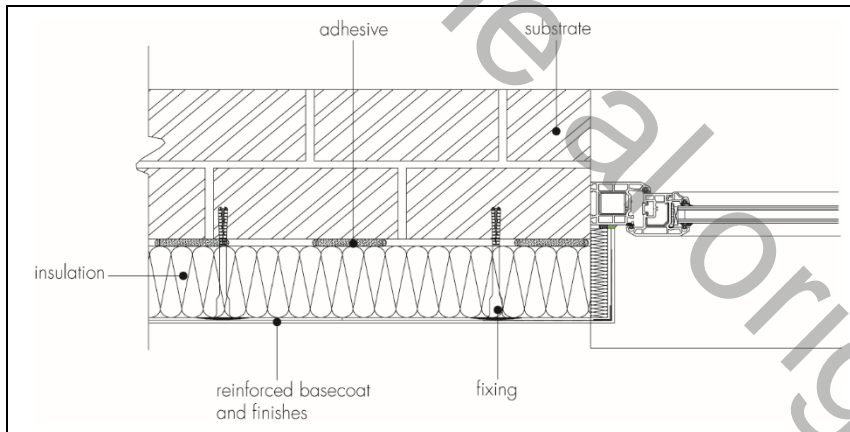

Figure 10 Corner details

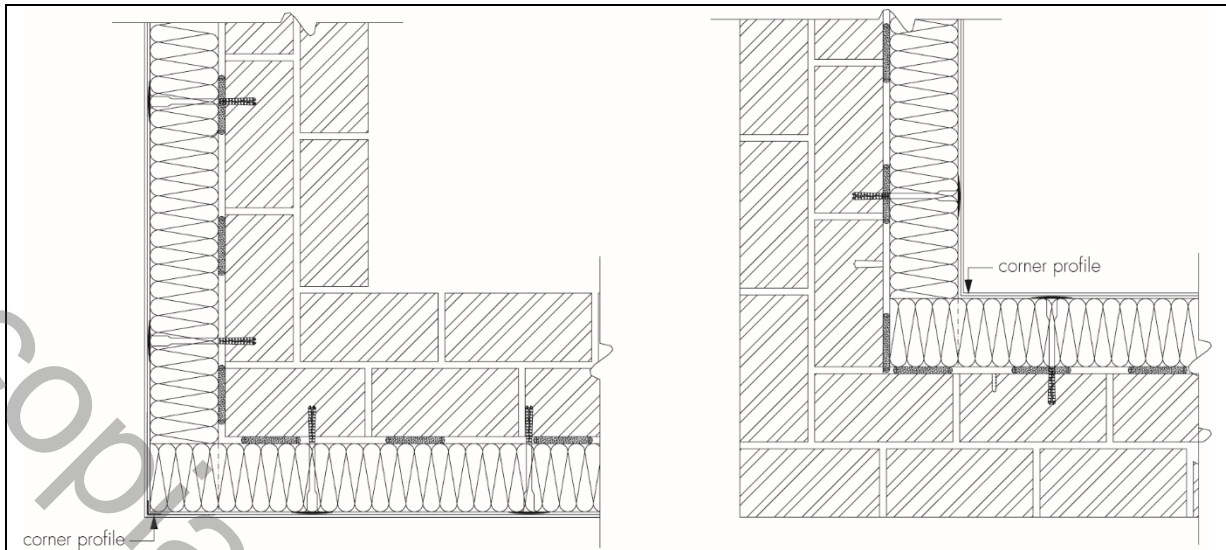
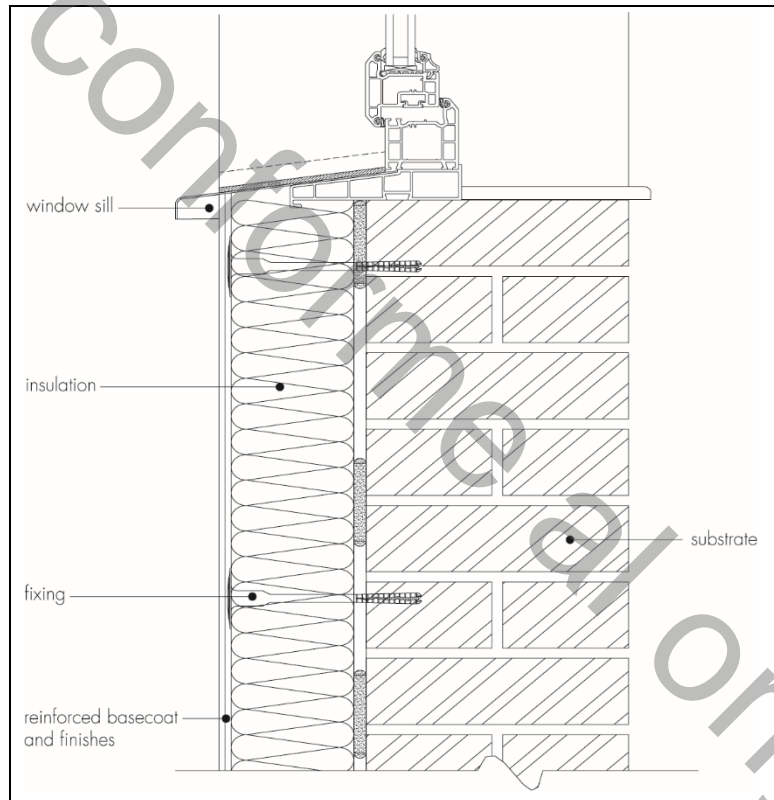

Figure 11 Window sill details



16.35 On completion of the installation, external fittings, eg rainwater goods, are re-fixed through the systems into the substrate.

17 Tests

Results of tests were assessed to determine:

- reaction to fire classification in accordance with UNI EN 13501-1 : 2019
- hygrothermal performance (heat/spray cycling)
- render/insulation bond strength
- resistance to hard body impact
- water vapour permeability
- water absorption.

18 Investigations

18.1 An examination was made of data relating to:

- durability
- adequacy of the fixings
- the risk of interstitial condensation
- thermal conductivity and example U values
- system wind load resistance.

18.2 The practicability of installation and the effectiveness of detailing techniques were examined.

18.3 The manufacturing process was evaluated, including the methods adopted for quality control, and details were obtained of the quality and composition of the materials used.

Bibliography

- BRE Report BR 135 : 2013 *Fire performance of external insulation of walls of multi-storey buildings*
- BRE Report BR 262 : 2002 *Thermal insulation: avoiding risks*
- BRE Report BR 443 : 2006 *Conventions for U-value calculations*
- BS 5250 : 2011 *Code of practice for control of condensation in buildings*
- BS 8000-0 : 2014 *Workmanship on construction sites — Introduction and general principles*
- BS 8000-2.2 : 1990 *Workmanship on building sites — Code of practice for concrete work — Sitework with in situ and precast concrete*
- BS 8000-3 : 2001 *Workmanship on building sites — Code of practice for masonry*
- BS EN 197-1 : 2011 *Cement — Composition, specifications and conformity criteria for common cements*
- BS EN 771-1 : 2011 *Specification for masonry units — Clay masonry units*
- BS EN 1990 : 2002 *Eurocode — Basis of structural design*
- NA to BS EN 1990 : 2002 + A1 : 2005 *UK National Annex for Eurocode — Basis of structural design*
- BS EN 1991-1-4 : 2005 *Eurocode 1 — Actions on structures — General actions — Wind actions*
- NA to BS EN 1991-1-4 : 2005 *UK National Annex to Eurocode 1 : Actions on structures — General actions — Wind actions*
- BS EN 1992-1-1 : 2004 + A1 : 2014 *Eurocode 2 — Design of concrete structures — General rules and rules for buildings*
- NA to BS EN 1992-1-1 : 2004 + A1 : 2014 *UK National Annex to Eurocode 2 — Design of concrete structures — General rules and rules for buildings*
- BS EN 1996-1-1 : 2005 *Eurocode 6 — Design of masonry structures — General rules for reinforced and unreinforced masonry structures*
- NA to BS EN 1996-1-1 : 2005 *UK National Annex to Eurocode 6 — Design of masonry structures — General rules for reinforced and unreinforced masonry structures*
- BS EN 1996-2 : 2006 *Eurocode 6 — Design of masonry structures — Design considerations, selection of materials and execution of masonry*
- NA to BS EN 1996-2 : 2006 *UK National Annex to Eurocode 6 — Design of masonry structures — Design considerations, selection of materials and execution of masonry*
- BS EN 12004 : 2007 *Adhesives for tiles — Requirements, evaluation of conformity, classification and designation*
- BS EN 13139 : 2013 *Aggregates for mortar*
- BS EN 13163 : 2012 + A2 : 2016 *Thermal insulation products for buildings — Factory made expanded polystyrene (EPS) products — Specification*
- BS EN 13165 : 2012 *Thermal insulation products for buildings — Factory made rigid polyurethane foam (PU) products — Specification*
- BS EN 13166 : 2012 *Thermal insulation products for buildings — Factory made phenolic foam (PF) products — Specification*
- BS EN 13888 : 2009 *Grout for tiles — Requirements, evaluation of conformity, classification and designation*
- BS EN 13914-1 : 2016 *Design, preparation and application of external rendering and internal plastering — External rendering*
- BS EN ISO 6946 : 2017 *Building components and building elements — Thermal resistance and thermal transmittance — Calculation method*
- BS EN ISO 11600 : 2003 *Building construction — Jointing products — Classification and requirements for sealants*
- ETAG 004 : 2013 *Guideline for European Technical Approval of External Thermal Insulation Composite Systems with Rendering*
- UNI EN 13501-1 : 2019 *Fire classification of construction products and building elements - Part 1: Classification using data from reaction to fire tests*

19 Conditions

19.1 This Certificate:

- relates only to the product/system that is named and described on the front page
- is issued only to the company, firm, organisation or person named on the front page – no other company, firm, organisation or person may hold or claim that this Certificate has been issued to them
- is valid only within the UK
- has to be read, considered and used as a whole document – it may be misleading and will be incomplete to be selective
- is copyright of the BBA
- is subject to English Law.

19.2 Publications, documents, specifications, legislation, regulations, standards and the like referenced in this Certificate are those that were current and/or deemed relevant by the BBA at the date of issue or reissue of this Certificate.

19.3 This Certificate will remain valid for an unlimited period provided that the product/system and its manufacture and/or fabrication, including all related and relevant parts and processes thereof:

- are maintained at or above the levels which have been assessed and found to be satisfactory by the BBA
- continue to be checked as and when deemed appropriate by the BBA under arrangements that it will determine
- are reviewed by the BBA as and when it considers appropriate.

19.4 The BBA has used due skill, care and diligence in preparing this Certificate, but no warranty is provided.

19.5 In issuing this Certificate the BBA is not responsible and is excluded from any liability to any company, firm, organisation or person, for any matters arising directly or indirectly from:

- the presence or absence of any patent, intellectual property or similar rights subsisting in the product/system or any other product/system
- the right of the Certificate holder to manufacture, supply, install, maintain or market the product/system
- actual installations of the product/system, including their nature, design, methods, performance, workmanship and maintenance
- any works and constructions in which the product/system is installed, including their nature, design, methods, performance, workmanship and maintenance
- any loss or damage, including personal injury, howsoever caused by the product/system, including its manufacture, supply, installation, use, maintenance and removal
- any claims by the manufacturer relating to CE marking.

19.6 Any information relating to the manufacture, supply, installation, use, maintenance and removal of this product/system which is contained or referred to in this Certificate is the minimum required to be met when the product/system is manufactured, supplied, installed, used, maintained and removed. It does not purport in any way to restate the requirements of the Health and Safety at Work etc. Act 1974, or of any other statutory, common law or other duty which may exist at the date of issue or reissue of this Certificate; nor is conformity with such information to be taken as satisfying the requirements of the 1974 Act or of any statutory, common law or other duty of care.