

# catalogo prodotti

products - productos



pitture e vernici - isolamento termico - malte tecniche - pavimenti in resina - sistema tintometrico youcolor  
paintes and varnishes - insulated renders - technical mortars - industrial flooring - youcolor tinting system  
pinturas y barnices - aislamiento térmico - morteros técnicos - suelo de resina - sistema de tintado youcolor



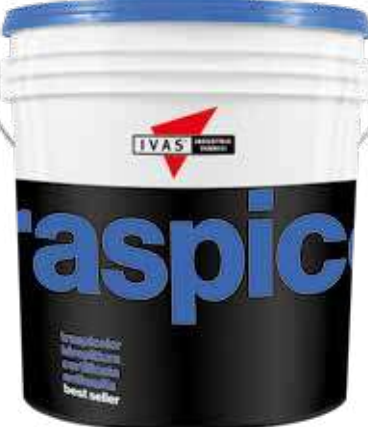

**NUOVO  
COLORE  
NUOVA  
IVAS!**





**dal 1953**  
**aggiungiamo valore all'edilizia**

seguendo questo principio guida, il Gruppo ha raggiunto una posizione di rilievo nel mercato delle costruzioni.

**since 1953**  
**we add value to construction**

Following this guiding principle, the Group has reached an important position in the construction market.

**desde 1953**  
**agregamos valor a la construcción**

Siguiendo este principio el Grupo ha logrado una posición destacada en el mercado de la construcción.







**la mission di ivas SpA**

**colori e sistemi  
per l'edilizia sostenibile**

fin dalla sua fondazione Ivas offre al mercato delle finiture edilizie soluzioni e tecnologie integrate, avendo come punto di riferimento l'alta qualità e il rispetto dell'ambiente.

**colours and systems  
for sustainable construction**

Since its foundation, Ivas has been offering integrated solutions and technologies to the market of building finishes, having as its reference point high quality and respect for the environment.

**colores y sistemas  
para la construcción sostenible**

desde su fundación, Ivas ha ofrecido soluciones y tecnologías integradas al mercado de acabados de edificación, teniendo como referencia la alta calidad y el respeto al ambiente.

## resumen

## summary

## sommario

legenda scheda prodotto	6
legenda icone	8

<b>PITTURE E VERNICI</b>	<b>interno</b>	
	<b>best sellers</b>	14
	<b>idrosmalti</b>	18
	<b>lavabili</b>	22
	<b>idropitture</b>	26
	<b>pitture</b>	30
	<b>vita sana</b>	36
	tabella sinottica prodotti da interno	44
	cicli per interno	46
	<b>esterno</b>	
	<b>paint ht</b>	50
	<b>exterior ht</b>	60
	<b>exterior</b>	66
	tabella sinottica prodotti da esterno	68
	cicli per esterno	70
	<b>interno-esterno</b>	
	<b>fondi</b>	74
	<b>fissativi</b>	78
	<b>stucchi</b>	82
	<b>coloranti universali</b>	86
	<b>interno-esterno</b>	
	<b>smalti h2O</b>	88
	<b>smalti</b>	92
	<b>antiruggini e fondi</b>	96
	<b>protettivi</b>	100
	<b>prodotti speciali</b>	106
<b>industria</b>	114	
<b>diluenti</b>	118	
<b>linea piscine</b>	120	
<b>linea legno</b>	124	

<b>ISOLAMENTO TERMICO</b>	<b>collanti e rasanti</b>	132
	<b>collanti e rasanti ht</b>	136
	<b>collanti e fuganti per modulari</b>	140
	<b>isolanti</b>	144
	<b>tasselli ht</b>	160
	<b>tasselli</b>	162
	<b>accessori ht</b>	164
	<b>accessori</b>	168
	<b>elementi di fissaggio</b>	176
	<b>davanzali</b>	182
	<b>reti in fibra di vetro</b>	184
	<b>finiture</b>	186
	<b>rivestimenti modulari</b>	194
	<b>decori e cornici</b>	196
	<b>attrezzature</b>	198

## resumen

## summary

## sommario

<b>MALTE TECNICHE</b>	<b>ripristino cls</b>	204
	<b>rasanti ht</b>	210
	<b>rasanti</b>	216
	<b>calce naturale</b>	222
	<b>collanti</b>	228
	<b>sigillanti</b>	234
	<b>deumidificanti</b>	238
	<b>massetti</b>	241
	<b>impermeabilizzanti</b>	244
	<b>linea casa</b>	250
	<b>additivi e leganti</b>	253
	<b>complementi</b>	255

<b>PAVIMENTI IN RESINA</b>	<b>impregnanti/antipolvere</b>	260
	<b>promotori d'adesione</b>	262
	<b>legante per malte spatolate</b>	264
	<b>rivestimenti a film</b>	266
	<b>rivestimenti murali</b>	270
	<b>autolivellanti</b>	272
	<b>protettivi e impermeabilizzanti</b>	276
	<b>riempitivi minerali</b>	278
	<b>poliurea</b>	280
	<b>accessori</b>	282

<b>YOU COLOR</b>	<b>macchine tintometriche</b>	286
	<b>coloranti concentrati</b>	292
	<b>prodotti a tintometro</b>	293

[	corner espositivi	304
	strumenti di vendita	308
	indice alfabetico prodotti	310



01.	nome prodotto	01.	nome product	01.	nombre del producto
02.	sottotitolo	02.	subtitle	02.	subtitular
03.	destinazione d'uso	03.	intended use	03.	uso previsto
04.	QR code scheda tecnica	04.	QR code data sheet	04.	código QR hoja de datos
05.	immagine confezione	05.	immagine packaging	05.	imagen envase
06.	descrizione prodotto	06.	product description	06.	descripción del Producto
07.	dati di applicazione	07.	application data	07.	datos de la aplicación
08.	icone tecniche	08.	technical icons	08.	iconos tecnicos
09.	icone certificazioni	09.	certifications icon	09.	iconos certificaciones
10.	icone proprietà	10.	properties icon	10.	iconos propiedades
11.	icone tecnologie	11.	technologies icon	11.	iconos tecnologías
A.	italiano	A.	Italian	A.	italiano
B.	inglese	B.	English	B.	inglés
C.	spagnolo	C.	Spanish	C.	español

01.

02.

03.

04.

**idromatt**



scheda tecnica



data sheet



ficha técnica

05.



06.

07.

idrosmalto opaco murale	<b>interno esterno</b>	Matt water-based wall enamel	<b>indoor outdoor</b>	Hidroesmalte mate de pared	<b>interior exterior</b>
Idrosmalto opaco murale, dotato di ottima lavabilità e copertura ad alta <b>Resa</b> . A base di resine acriliche all'acqua e cariche pregiate, a viscosità idonea ad evitare colature e schizzi. Particolarmente indicato per ambienti ad uso pubblico. Idoneo per ambienti che devono contenere alimenti, Certificato HACCP. La Classe TVOC A+ lo rende idoneo per ottemperare ai protocolli CAM, Leed e Breeam. Per uso professionale.		Matt water-based wall enamel with superb washability and high coverage. Based on water-based acrylic resins and high quality fillers, with a viscosity able to prevent dripping and splashing. Particularly suited for use in public places. Suitable for rooms where foodstuffs are stored. HACCP Certified.		Hidroesmalte mate de pared, dotado de excelente lavabilidad y capacidad cubriente de alto rendimiento. A base de resinas acrílicas al agua y cargas de calidad, con la viscosidad adecuada para evitar goterones y salpicaduras. Particolarmente indicado para espacios públicos. Idóneo para lugares que vayan a contener alimentos, Certificado HACCP. Para uso profesional.	
<b>Attrezzatura:</b> pennello, rullo, airless <b>Diluizione:</b> acqua - 5-10% <b>Resa (2 mani):</b> 7-8 m <sup>2</sup> /l - Per confezione (12 l): 96 m <sup>2</sup> <b>Colore:</b> bianco e colorato		<b>Equipment:</b> brush, roller, airless <b>Dilution:</b> water - 5-10% <b>Coverage (2 coats):</b> 7-8 m <sup>2</sup> /l - Per packaging (12 l): 96 m <sup>2</sup> <b>Color:</b> white and colored		<b>Herramientas:</b> brocha, rodillo, pistola pulverizadora <b>Dilución:</b> agua - 5-10% <b>Rendimiento (2 capas):</b> 7-8 m <sup>2</sup> /l - Por envase (12 l): 96 m <sup>2</sup> <b>Color:</b> blanco y colorido	

tecniche	certificazioni	proprietà	tecnologie
COLOURABLE WATER BASED BRUSH ROLLER AIRLESS	A+ haccp	S1 WASHABLE V3 BREATHABLE class 2 COVERAGE matt BRILLIANCE	Resistance 5

08.

09.

10.

11.

A.

B.

C.

## ICONE PROPRIETÀ

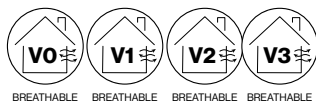

grado di traspirabilità dal più alto al più basso - degree of breathability from the highest to the lowest - grado de transpirabilidad de mayor a menor

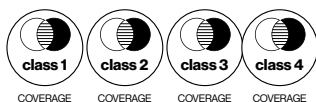

grado di copertura dal più alto al più basso - degree of covering from the highest to the lowest - grado de cobertura de mayor a menor



grado di lavabilità dal più alto al più basso - degree of washability from the highest to the lowest - grado de lavabilidad de mayor a menor



opaco / satinato / lucido  
matt / satin / glossy  
mate / satinado / brillante



pedonabile - walkable - transitabile



carrabile - carriageable - transitabile



anticondensa - anti condensation -  
anticondensación



termico - thermal - térmico



minerale - mineral - mineral



pulibile - cleanable - lavable



tecnologia etica ivas - ivas ethical  
technology - ivas tecnologia ética

## ICONE TECNOLOGIE



protezione da tutti i ceppi batterici -  
protection from all bacterial strains  
- protección contra todas las cepas  
bacterianas



protezione dall'attacco di alghe,  
funghi e muffe - protection against  
attack of algae, fungi and moulds -  
protección contra el ataque de algas,  
hongos y mohos



formulazione idrofobizzante -  
hydrophobizzant formulation -  
formulación hidrofóbica



nanotecnologia fotocatalitica con  
potere autopulente - photocatalytic  
nanotechnology with self-cleaning  
power - nanotecnología fotocatalítica  
con poder autolimpiante



formulazione a pigmenti a basso  
assorbimento UV - low UV absorption  
pigment formulation - formulación de  
pigmento de baja absorción UV



formulazione che minimizza i rischi  
di decolorazione nei colori forti -  
formulation that minimizes the risk  
of discoloration in strong colours -  
formulación que minimiza el riesgo de  
decoloración en colores fuertes



grado di protezione cls dal più basso  
al più alto - degree of protection cls  
from lowest to highest - grado de  
protección del hormigón de menor  
a mayor

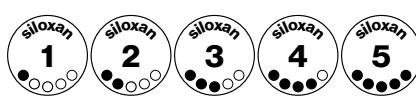

percentuale di silossani contenuti  
dal più basso al più alto - percentage  
of siloxanes contained from lowest to  
highest - de menor a mayor



grado di resistenza alla tenuta dal  
più basso al più alto - degree of  
resistance to leakage from lowest to  
highest - grado de resistencia al  
estancqueidad de menor a mayor

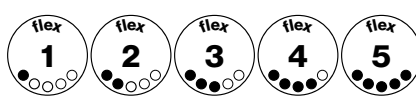

grado di flessibilità dal più basso  
al più alto - degree of flexibility  
from lowest to highest - grado de  
flexibilidad de menor a mayor

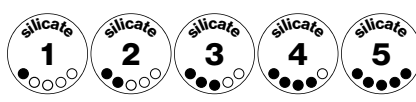

percentuale di silicati contenuti dal  
più basso al più alto - percentage  
of silicates contained from lowest  
to highest - porcentaje de silicatos  
contenidos de menor a mayor



## ICONE TERMOK8



per bioedilizia - for green building -  
para la construcción ecológica



conducibilità termica  
thermal conductivity  
conductividad térmica  
0,023 W/(m·K)



conducibilità termica  
thermal conductivity  
conductividad térmica  
0,040 W/(m·K)



per accedere al bonus  
ristrutturazioni 110% - to access  
the restructuring bonus 110%  
(Italy) - para acceder al bono de  
reestructuración del 110% (Italia)



conducibilità termica  
thermal conductivity  
conductividad térmica  
0,025 W/(m·K)



conducibilità termica  
thermal conductivity  
conductividad térmica  
0,045 W/(m·K)



lastre certificate CAM - certified  
slabs CAM - placas certificadas  
CAM



conducibilità termica  
thermal conductivity  
conductividad térmica  
0,028 W/(m·K)



materiali o sistemi minerali -  
mineral materials or systems -  
materiales o sistemas minerales



economicità - cost-effectiveness -  
rentabilidad



conducibilità termica  
thermal conductivity  
conductividad térmica  
0,029 W/(m·K)



grande resistenza agli urti -  
grande resistenza agli urti - gran  
resistencia al impacto



elevato isolamento termico - high  
thermal insulation - alto aislamiento  
térmico



conducibilità termica  
thermal conductivity  
conductividad térmica  
0,030 W/(m·K)



grande resistenza al fuoco - great  
resistance to fire - gran resistencia  
al fuego



lastre certificate EPD - certified  
slabs EPD - placas certificadas  
EPD



conducibilità termica  
thermal conductivity  
conductividad térmica  
0,031 W/(m·K)



Termok8 modular design



facilità di posa - ease of installation -  
facilidad de instalación



conducibilità termica  
thermal conductivity  
conductividad térmica  
0,032 W/(m·K)

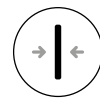

per sistemi con spessori ridotti - for  
systems with reduced thickness  
- para sistemas con espesores  
reducidos



per isolamento termoacustico - for  
thermal and acoustic insulation -  
para aislamiento térmico y acústico



conducibilità termica  
thermal conductivity  
conductividad térmica  
0,033 W/(m·K)



per superfici difficili - for difficult  
surfaces - para superficies difíciles



Termok8 design



conducibilità termica  
thermal conductivity  
conductividad térmica  
0,034 W/(m·K)



conducibilità termica  
thermal conductivity  
conductividad térmica  
0,020 W/(m·K)



conducibilità termica  
thermal conductivity  
conductividad térmica  
0,035 W/(m·K)



conducibilità termica  
thermal conductivity  
conductividad térmica  
0,021 W/(m·K)



conducibilità termica  
thermal conductivity  
conductividad térmica  
0,036 W/(m·K)



**IVAS<sup>®</sup>**

**INDUSTRIA  
VERNICI**

---

**DIVISIONE  
PITTURE E VERNICI**

**PIT  
TURE  
E  
VER  
NICI**





**best e**

# prodotti

traspicolor active

enjoy 1 coat



# seller

## traspicolar active



scheda  
tecnica



data  
sheet



ficha  
técnica



idropittura traspirante antimuffa certificata	interno	matt washable water-based paint with masking effect	indoor	pittura al acqua traspirante antimoho certificata	interiores
<p>Idropittura murale antimuffa altamente traspirante formulata con resine viniliche con elevata copertura e punto di bianco. Questa pittura contiene prodotto biocida con proprietà fungicida e algicida basato sul principio attivo active. Certificato dal Fraunhofer-Institut für Bauphysik di Monaco. La Classe TVOC A+ lo rende idoneo per ottemperare ai protocolli CAM, Leed Breeam. Per uso professionale.</p> <p><b>Attrezzatura:</b> pennello, rullo, airless <b>Diluizione:</b> acqua - 20-25% <b>Resa</b> (2 mani): 4-5 m<sup>2</sup>/l - Per confezione (14 l): 70 m<sup>2</sup> <b>Colore:</b> solo bianco</p>		<p>Highly breathable water-based paint resistant to mould and mildew formulated with vinyl resins offering high coverage and whiteness. This paint contains a biocidal product with fungicidal and algacidal properties based on the active ingredient. Certified by Fraunhofer-Institut für Bauphysik of Munich. Classified TVOC A+, it complies with Leed Breeam protocols. For professional use.</p> <p><b>Equipment:</b> brush, roller, airless <b>Dilution:</b> water - 20-25% <b>Coverage</b> (2 coats): 4-5 m<sup>2</sup>/l - Per packaging (14 l): 70 m<sup>2</sup> <b>Color:</b> only white</p>		<p>Pintura al agua de pared altamente traspirante antimoho formulada con resinas vinilicas con gran capacidad cubriente y agradable punto de blanco. Esta pintura contiene un producto biocida con propiedades fungicidas y algucidas basadas en el principio activo active. Certificada por el Fraunhofer-Institut für Bauphysik de Munich. La Clase TVOC A+ la hace idónea para cumplir con los protocolos Leed Breeam. Para uso profesional.</p> <p><b>Herramientas:</b> brocha, rodillo, pistola pulverizadora <b>Dilución:</b> agua - 20-25% <b>Rendimiento</b> (2 capas): 4-5 m<sup>2</sup>/l - Por envase (14 l): 70 m<sup>2</sup> <b>Color:</b> solo blanco</p>	

tecniche	certificazioni	proprietà	tecnologie
WATER BASED BRUSH ROLLER AIRLESS	A+ muffe batteri	V1 BREATHABLE class 2 COVERAGE	active

enjoy 1 coat



scheda  
tecnica



data  
sheet



ficha  
técnica



idropittura lavabile a mano unica	interno	Single coat, washable water-based paint	indoor	pittura al agua lavable de una sola mano	interiores
Idropittura lavabile a mano unica a base di resine acriliche ed extender molto fini che conferiscono un'eccezionale copertura e gradevole punto di bianco. Forma una finitura uniforme applicando un'unica mano. Ideale per cartongesso. La Classe TVOC A+ lo rende idoneo per ottemperare ai protocolli CAM, Leed e Breeam. Per uso professionale.		Single coat, washable water-based paint with acrylic resins and very fine extenders that ensure exceptional coverage and an attractive degree of whiteness. Forms a uniform topcoat in a single application. Ideal for plasterboard. Classified TVOC A+, it complies with Leed Breeam protocols. For professional use.		Pintura al agua lavable de una sola mano a base de resinas acrílicas y extender muy finos que proporcionan una excepcional capacidad cubriente y un agradable punto de blanco. Forma un acabado uniforme aplicando una sola mano. Ideal para cartón-yeso. La Clase TVOC A+ la hace idónea para cumplir con los protocolos Leed Breeam. Para uso profesional.	
<b>Attrezzatura:</b> pennello, rullo, airless <b>Diluizione:</b> pronto all'uso <b>Resa</b> (1 mano): 5-6 m <sup>2</sup> /l - Per confezione (14 l): 70-80 m <sup>2</sup> <b>Colore:</b> bianco e colorato		<b>Equipment:</b> brush, roller, airless <b>Dilution:</b> ready to use <b>Coverage</b> (1 coat): 5-6 m <sup>2</sup> /l - Per packaging (14 l): 70-80 m <sup>2</sup> <b>Color:</b> white and colored		<b>Herramientas:</b> brocha, rodillo, pistola pulverizadora <b>Dilución:</b> listo para usar <b>Rendimiento</b> (1 capa): 5-6 m <sup>2</sup> /l - Por envase (14 l): 70-80 m <sup>2</sup> <b>Color:</b> blanco y colorido	

tecniche						certificazioni		proprietà				tecnologie			



# idrosm

idrosmalti murali di alto pregio

# prodotti

idromatt

idrosatin

idrogloss



# malati



## idromatt



scheda  
tecnica



data  
sheet



ficha  
técnica

idrosmalto opaco murale	interno esterno	matt water-based wall enamel	indoor outdoor	hidroesmalte mate de pared	interior exterior
<p>Idrosmalto opaco murale, dotato di ottima lavabilità e copertura ad alta resa. A base di resine acriliche all'acqua e cariche pregiate, a viscosità idonea ad evitare colature e schizzi. Particolarmente indicato per ambienti ad uso pubblico. Idoneo per ambienti che devono contenere alimenti, Certificato HACCP. La Classe TVOC A+ lo rende idoneo per ottemperare ai protocolli CAM, Leed e Breeam. Per uso professionale.</p>		<p>Matt water-based wall enamel with superb washability and high coverage. Based on water-based acrylic resins and high quality fillers, with a viscosity able to prevent dripping and splashing. Particularly suited for use in public places. Suitable for rooms where foodstuffs are stored. HACCP Certified. Classified TVOC A+, it complies with Leed Breeam protocols. For professional use.</p>		<p>Hidroesmalte mate de pared, dotado de excelente lavabilidad y capacidad cubriente de alto rendimiento. A base de resinas acrílicas al agua y cargas de calidad, con la viscosidad adecuada para evitar goterones y salpicaduras. Particolarmente indicado para espacios públicos. Idóneo para lugares que vayan a contener alimentos, Certificado HACCP. La Clase TVOC A+ la hace idónea para cumplir con los protocolos Leed Breeam. Para uso profesional.</p>	
<p><b>Attrezzatura:</b> pennello, rullo, airless <b>Diluizione:</b> acqua - 5-10% <b>Resa</b> (2 mani): 7-8 m<sup>2</sup>/l - Per confezione (12 l): 96 m<sup>2</sup> <b>Colore:</b> bianco e colorato</p>		<p><b>Equipment:</b> brush, roller, airless <b>Dilution:</b> water - 5-10% <b>Coverage</b> (2 coats): 7-8 m<sup>2</sup>/l - Per packaging (12 l): 96 m<sup>2</sup> <b>Color:</b> white and colored</p>		<p><b>Herramientas:</b> brocha, rodillo, pistola pulverizadora <b>Dilución:</b> agua - 5-10% <b>Rendimiento</b> (2 capas): 7-8 m<sup>2</sup>/l - Por envase (12 l): 96 m<sup>2</sup> <b>Color:</b> blanco y colorido</p>	

tecniche	certificazioni	proprietà	tecnologie

## idrosatin



scheda  
tecnica



data  
sheet



ficha  
técnica

idrosmalto satinato murale	interno esterno	satin water-based wall enamel	indoor outdoor	hidroesmalte satinado de pared	interior exterior
<p>Idrosmalto satinato murale, dotato di ottima lavabilità e copertura ad alta resa. A base di resine acriliche all'acqua e cariche pregiate, a viscosità idonea ad evitare colature e schizzi. Particolarmente indicato per ambienti ad uso pubblico. Idoneo per ambienti che devono contenere alimenti, Certificato HACCP. La Classe TVOC A+ lo rende idoneo per ottemperare ai protocolli CAM, Leed e Breeam. Per uso professionale.</p>		<p>Satin water-based wall enamel with superb washability and high coverage. Based on water-based acrylic resins and high quality fillers, with a viscosity able to prevent dripping and splashing. Particularly suited for use in public places. Suitable for rooms where foodstuffs are stored. HACCP Certified. Classified TVOC A+, it complies with Leed Breeam protocols. For professional use.</p>		<p>Hidroesmalte satinado de pared, dotado de excelente lavabilidad y capacidad cubriente de alto rendimiento. A base de resinas acrílicas al agua y cargas de calidad, con la viscosidad adecuada para evitar goterones y salpicaduras. Particolarmente indicado para espacios públicos. Idóneo para lugares que vayan a contener alimentos, Certificado HACCP. La Clase TVOC A+ la hace idónea para cumplir con los protocolos Leed Breeam. Para uso profesional.</p>	
<p><b>Attrezzatura:</b> pennello, rullo, airless <b>Diluizione:</b> acqua - 5-10% <b>Resa</b> (2 mani): 7-8 m<sup>2</sup>/l - Per confezione (12 l): 96 m<sup>2</sup> <b>Colore:</b> bianco e colorato</p>		<p><b>Equipment:</b> brush, roller, airless <b>Dilution:</b> water - 5-10% <b>Coverage</b> (2 coats): 7-8 m<sup>2</sup>/l - Per packaging (12 l): 96 m<sup>2</sup> <b>Color:</b> white and colored</p>		<p><b>Herramientas:</b> brocha, rodillo, pistola pulverizadora <b>Dilución:</b> agua - 5-10% <b>Rendimiento</b> (2 capas): 7-8 m<sup>2</sup>/l - Por envase (12 l): 96 m<sup>2</sup> <b>Color:</b> blanco y colorido</p>	

tecniche	certificazioni	proprietà	tecnologie

# idrogloss



scheda  
tecnica



data  
sheet



ficha  
técnica



idrosmalto lucido murale	interno esterno	glossy water-based enamel for walls	indoor outdoor	esmalte al agua brillante para paredes	interior exterior
<p>Idrosmalto lucido murale, dotato di ottima lavabilità e copertura ad alta <b>Resa</b>. A base di resine acriliche all'acqua e cariche pregiate, a viscosità idonea ad evitare colature e schizzi. Particolarmente indicato per ambienti ad uso pubblico. Idoneo per ambienti che devono contenere alimenti, Certificato HACCP. La Classe TVOC A+ lo rende idoneo per ottemperare ai protocolli CAM, Leed e Breeam. Per uso professionale.</p>		<p>Satin water-based wall enamel with superb washability and high coverage. Based on water-based acrylic resins and high quality fillers, with a viscosity able to prevent dripping and splashing. Particularly suited for use in public places. Suitable for rooms where foodstuffs are stored. HACCP Certified. Classified TVOC A+, it complies with Leed Breeam protocols. For professional use.</p>		<p>Hidroesmalte brillante de pared, dotado de excelente lavabilidad y capacidad cubriente de alto rendimiento. A base de resinas acrílicas al agua y cargas de calidad, con la viscosidad adecuada para evitar goterones y salpicaduras. Particularmente indicado para espacios públicos. Idóneo para lugares que vayan a contener alimentos, Certificado HACCP. La Clase TVOC A+ la hace idónea para cumplir con los protocolos Leed Breeam. Para uso profesional.</p>	
<p><b>Attrezzatura:</b> pennello, rullo, airless <b>Diluizione:</b> acqua - 5-10% <b>Resa</b> (2 mani): 7-8 m<sup>2</sup>/l - Per confezione (12 l): 96 m<sup>2</sup> <b>Colore:</b> bianco e colorato</p>		<p><b>Equipment:</b> brush, roller, airless <b>Dilution:</b> water - 5-10% <b>Coverage</b> (2 coats): 7-8 m<sup>2</sup>/l - Per packaging (12 l): 96 m<sup>2</sup> <b>Color:</b> white and colored</p>		<p><b>Herramientas:</b> brocha, rodillo, pistola pulverizadora <b>Dilución:</b> agua - 5-10% <b>Rendimiento</b> (2 capas): 7-8 m<sup>2</sup>/l - Por envase (12 l): 96 m<sup>2</sup> <b>Color:</b> blanco y colorido</p>	

tecniche	certificazioni	proprietà	tecnologie

# lavabili

lavabili di alto pregio

# prodotti

clean matt

luxury

tech active

sol-tex



## clean matt



<p>idropittura superlavabile smacchiabile agli ioni d'argento</p> <p><b>interno</b></p>	<p>highly washable stain-resistant water-based paint with silver ions</p> <p><b>indoor</b></p>	<p>pittura al acqua superlavabile, fácil de limpiar, con iones de plata</p> <p><b>interiores</b></p>
<p>Idropittura superlavabile smacchiabile, contenente ioni d'argento attivi nel contrastare in modo naturale la proliferazione dei microrganismi quali muffe e batteri. La nuova tecnologia Clean conferisce al prodotto elevata resistenza alle macchie e da una estrema facilità di pulizia. Certificato per ambienti che devono contenere alimenti e certificato HACCP. La Classe TVOC A+ lo rende idoneo per ottemperare ai protocolli CAM, Leed Breeam. Per uso professionale.</p>	<p>Highly washable stain-resistant water-based paint with active silver ions that naturally counter the proliferation of microorganisms such as mould, mildew and bacteria. The new Clean technology makes the product highly resistant to stains and easy to clean. Certified for rooms where foodstuffs are stored and HACCP certified. Classified TVOC A+, it complies with Leed Breeam protocols. For professional use.</p>	<p>Pintura al agua superlavable, fácil de limpiar, contiene iones de plata activos que combaten de forma natural la proliferación de los microorganismos como mohos y bacterias. La nueva tecnología Clean proporciona al producto una gran resistencia a las manchas y extrema facilidad de limpieza. Certificada para lugares que vayan a contener alimentos y certificada HACCP. La Clase TVOC A+ la hace idónea para cumplir con los protocolos Leed Breeam. Para interiores. Para uso profesional.</p>
<p><b>Attrezzatura:</b> pennello, rullo, airless <b>Diluizione:</b> pronto all'uso <b>Resa</b> (2 mani): 5-6 m<sup>2</sup>/l - Per confezione (12 l): 72 m<sup>2</sup> <b>Colore:</b> bianco e colorato</p>	<p><b>Equipment:</b> brush, roller, airless <b>Dilution:</b> ready to use <b>Coverage</b> (2 coats): 5-6 m<sup>2</sup>/l - Per packaging (12 l): 72 m<sup>2</sup> <b>Color:</b> white and colored</p>	<p><b>Herramientas:</b> brocha, rodillo, pistola pulverizadora <b>Dilución:</b> listo para usar <b>Rendimiento</b> (2 capas): 5-6 m<sup>2</sup>/l - Por envase (12 l): 72 m<sup>2</sup> <b>Color:</b> blanco y colorido</p>



scheda  
tecnica



data  
sheet



ficha  
técnica

## tecniche



COLOURABLE



WATER BASED



BRUSH



ROLLER



AIRLESS



READY TO USE

## certificazioni



## proprietà



## tecnologie

## luxury



<p>idropittura superlavabile opaca</p> <p><b>interno esterno</b></p>	<p>matt highly washable water-based paint</p> <p><b>indoor outdoor</b></p>	<p>pittura al acqua superlavabile mate</p> <p><b>interior exterior</b></p>
<p>Idropittura superlavabile opaca a base di resine acriliche in dispersione acquosa, cariche minerali inerti e pigmenti selezionati solidi alla luce. Ottima copertura e bassa presa: di sporco. Mantiene un aspetto vellutato e uniforme anche su superfici lisce. La Classe TVOC A+ lo rende idoneo per ottemperare ai protocolli CAM, Leed e Breeam. Per uso professionale.</p>	<p>Matt highly washable water-based paint with acrylic resins dispersed in water, inert mineral fillers and selected lightfast pigments. Superb coverage and low dirt retention. Maintains a uniform, velvety appearance, even on smooth surfaces. Classified TVOC A+, it complies with Leed Breeam protocols. For professional use.</p>	<p>Pintura al agua superlavable mate a base de resinas acrílicas en dispersión acuosa, cargadas minerales inertes y pigmentos seleccionados sólidos a la luz. Excelente capacidad cubriente y baja retención de suciedad. Mantiene un aspecto aterciopelado y uniforme también sobre superficies lisas. La Clase TVOC A+ la hace idónea para cumplir con los protocolos Leed Breeam. Para uso profesional.</p>
<p><b>Attrezzatura:</b> pennello, rullo, airless <b>Diluizione:</b> acqua - 10-15% <b>Resa</b> (2 mani): 6-8 m<sup>2</sup>/l - Per confezione (12 l): 96 m<sup>2</sup> <b>Colore:</b> bianco e colorato</p>	<p><b>Equipment:</b> brush, roller, airless <b>Dilution:</b> water - 10-15% <b>Coverage</b> (2 coats): 6-8 m<sup>2</sup>/l - Per packaging (12 l): 96 m<sup>2</sup> <b>Color:</b> white and colored</p>	<p><b>Herramientas:</b> brocha, rodillo, pistola pulverizadora <b>Dilución:</b> agua - 10-15% <b>Rendimiento</b> (2 capas): 6-8 m<sup>2</sup>/l - Por envase (12 l): 96 m<sup>2</sup> <b>Color:</b> blanco y colorido</p>



scheda  
tecnica



data  
sheet



ficha  
técnica

## tecniche



COLOURABLE



WATER BASED



BRUSH



ROLLER



AIRLESS

## certificazioni



## proprietà



## tecnologie

## tech active



scheda  
tecnica



data  
sheet



ficha  
técnica



<p>idropittura lavabile opaca mascherante antimuffa</p> <p><b>interno</b></p>	<p>matt washable water-based paint with masking effect</p> <p><b>indoor</b></p>	<p>pintura al agua lavable mate con efecto enmascarante</p> <p><b>interiores</b></p>
<p>Idropittura lavabile opaca mascherante ad elevata copertura e punto di bianco. La sua particolare reologia fornisce ottima distensione e facilità di applicazione. Possiede inoltre caratteristiche antischizzo che facilitano l'applicazione a rullo. Consigliato per cartongesso. La Classe TVOC A+ lo rende idoneo per ottemperare ai protocolli CAM, Leed e Breeam. Questa pittura contiene prodotto biocida con proprietà fungicida e alghicida basato sul principio attivo active. Per uso professionale.</p>	<p>Matt washable water-based paint with high coverage and whiteness. Its special rheology ensures excellent spreadability and easy application. It also prevents splashing thus facilitating roller application. Recommended for plasterboard. Classified TVOC A+, it complies with Leed Breeam protocols. This paint contains a biocidal product with fungicidal and algacidal properties based on the active ingredient. For professional use.</p>	<p>Pintura al agua lavable mate con efecto enmascarante de alta capacidad cubriente y punto de blanco. Su particular reologia proporciona una excelente distensión y facilidad de aplicación. Posee además características antisalpicadura que facilita la aplicación con rodillo. Aconsejada para cartón-yeso. La Clase TVOC A+ la hace idónea para cumplir con los protocolos Leed Breeam. Esta pintura contiene un producto biocida con propiedades fungicidas y alguicidas basadas en el principio activo active. Para interiores. Para uso profesional.</p>
<p><b>Attrezzatura:</b> pennello, rullo, airless <b>Diluizione:</b> acqua - 10-15% <b>Resa</b> (2 mani): 6-7 m<sup>2</sup>/l - Per confezione (14 l): 98 m<sup>2</sup> <b>Colore:</b> bianco e colorato</p>	<p><b>Equipment:</b> brush, roller, airless <b>Dilution:</b> water - 10-15% <b>Coverage</b> (2 coats): 6-7 m<sup>2</sup>/l - Per packaging (14 l): 98 m<sup>2</sup> <b>Color:</b> white and colored</p>	<p><b>Herramientas:</b> brocha, rodillo, pistola pulverizadora <b>Dilución:</b> agua - 10-15% <b>Rendimiento</b> (2 capas): 6-7 m<sup>2</sup>/l - Por envase (14 l): 98 m<sup>2</sup> <b>Color:</b> blanco y colorido</p>

<p><b>tecniche</b></p>	<p><b>certificazioni</b></p>	<p><b>proprietà</b></p>	<p><b>tecnologie</b></p>
------------------------	------------------------------	-------------------------	--------------------------

## sol-tex



scheda  
tecnica



data  
sheet



ficha  
técnica



<p>idropittura lavabile riempitiva</p> <p><b>interno</b></p>	<p>Washable water-based paint with filling power</p> <p><b>indoor</b></p>	<p>pintura al agua lavable para relleno</p> <p><b>interiores</b></p>
<p>Idropittura lavabile ad alto riempimento formulata a base di resine acriliche in dispersione acquosa, cariche minerali inerti e pigmenti selezionati solidi alla luce. La Classe TVOC A+ lo rende idoneo per ottemperare ai protocolli CAM, Leed e Breeam. Per uso professionale.</p>	<p>Washable water-based paint with high filling power, based on acrylic resins dispersed in water, inert mineral fillers and selected lightfast pigments. Classified TVOC A+, it complies with Leed Breeam protocols. For professional use.</p>	<p>Pintura al agua lavable con alta capacidad de relleno formulada a base de resinas acrílicas en dispersión acuosa, cargas minerales inertes y pigmentos seleccionados sólidos a la luz. La Clase TVOC A+ la hace idónea para cumplir con los protocolos Leed y Breeam. Para interiores. Para uso profesional.</p>
<p><b>Attrezzatura:</b> pennello, rullo, airless <b>Diluizione:</b> acqua - 20-25% <b>Resa</b> (2 mani): 6-7 m<sup>2</sup>/l - Per confezione (14 l): 98 m<sup>2</sup> <b>Colore:</b> bianco e colorato</p>	<p><b>Equipment:</b> brush, roller, airless <b>Dilution:</b> water - 20-25% <b>Coverage</b> (2 coats): 6-7 m<sup>2</sup>/l - Per packaging (14 l): 98 m<sup>2</sup> <b>Color:</b> white and colored</p>	<p><b>Herramientas:</b> brocha, rodillo, pistola pulverizadora <b>Dilución:</b> agua - 20-25% <b>Rendimiento</b> (2 capas): 6-7 m<sup>2</sup>/l - Por envase (14 l): 98 m<sup>2</sup> <b>Color:</b> blanco y colorido</p>

<p><b>tecniche</b></p>	<p><b>certificazioni</b></p>	<p><b>proprietà</b></p>	<p><b>tecnologie</b></p>
------------------------	------------------------------	-------------------------	--------------------------





# idropitt

idropitture murali

# prodotti

silan tech

traspinterno

white cream

mural verde

# ture

## silan tech



scheda  
tecnica



data  
sheet



ficha  
técnica



idropittura traspirante acrisilossanica antimuffa	<b>interno</b>	breathable water-based acrylic-siloxane paint resistant to mould and mildew	<b>indoor</b>	pintura al agua transpirante acrisiloxánica antimoho	<b>interiores</b>
Idropittura a base di resine acrisilossaniche e cariche minerali che la rendono altamente traspirante ed idrorepellente. Questa pittura contiene prodotto biocida con proprietà fungicida e algicida basato sul principio attivo active. Particolarmente indicata su cicli deumidificanti e minerali. Per uso professionale.		Water-based paint with acrylic-siloxane resins and mineral fillers that make it highly breathable and water-repellent. This paint contains a biocidal product with fungicidal and algicidal properties based on the active ingredient. Particularly suitable for dehumidifying and mineral processes. For professional use.		Pintura al agua a base de resinas acrisiloxánicas y cargas minerales que la hacen muy transpirante e hidro-repelente. Esta pintura contiene un producto biocida con propiedades fungicidas y algucidas basadas en el principio activo active. Particularmente indicada para ciclos deshumidificantes y minerales. Para uso profesional.	
<b>Attrezzatura:</b> pennello, rullo, airless <b>Diluizione:</b> acqua - 15-20% <b>Resa</b> (2 mani): 4-5 m <sup>2</sup> /l - Per confezione (14 l): 70 m <sup>2</sup> <b>Colore:</b> bianco e colorato		<b>Equipment:</b> brush, roller, airless <b>Dilution:</b> water - 15-20% <b>Coverage</b> (2 coats): 4-5 m <sup>2</sup> /l - Per packaging (14 l): 70 m <sup>2</sup> <b>Color:</b> white and colored		<b>Herramientas:</b> brocha, rodillo, pistola pulverizadora <b>Dilución:</b> agua - 15-20% <b>Rendimiento</b> (2 capas): 4-5 m <sup>2</sup> /l - Por envase (14 l): 70 m <sup>2</sup> <b>Color:</b> blanco y colorido	

tecniche	certificazioni	proprietà	tecnologie

## traspinterno



scheda  
tecnica



data  
sheet



ficha  
técnica



idropittura traspirante universale	<b>interno</b>	universal breathable water-based paint for indoor use	<b>indoor</b>	pintura al agua transpirante universal para interiores	<b>interiores</b>
Idropittura murale traspirante formulata con resine viniliche, cariche ed inerti, bilanciati in modo da ottenere una finitura alcaliresistente e con un punto di bianco caldo. Facile applicazione. Possibilità di realizzare colori chiari e tinte tenui. Per uso professionale.		Breathable, water-based wall paint formulated with vinyl resins, fillers and inert material, balanced to produce an alkali-resistant topcoat with warm whiteness. Easy to apply. Light and pastel colours can be produced. For professional use.		Pintura al agua de pared, transpirante, formulada con resinas vinilicas, cargas y áridos, equilibrados de modo que se pueda obtener un acabado resistente a los álcalis y con un punto de blanco cálido. Fácil aplicación. Posibilidad de realizar colores claros y tintes tenuis. Para uso profesional.	
<b>Attrezzatura:</b> pennello, rullo, airless <b>Diluizione:</b> acqua - 20-25% <b>Resa</b> (2 mani): 3,5-4,5 m <sup>2</sup> /l - Per confezione (14 l): 63 m <sup>2</sup> <b>Colore:</b> bianco e colorato		<b>Equipment:</b> brush, roller, airless <b>Dilution:</b> water - 20-25% <b>Coverage</b> (2 coats): 3,5-4,5 m <sup>2</sup> /l - Per packaging (14 l): 63 m <sup>2</sup> <b>Color:</b> white and colored		<b>Herramientas:</b> brocha, rodillo, pistola pulverizadora <b>Dilución:</b> agua - 20-25% <b>Rendimiento</b> (2 capas): 3,5-4,5 m <sup>2</sup> /l - Por envase (14 l): 63 m <sup>2</sup> <b>Color:</b> blanco y colorido	

tecniche	certificazioni	proprietà	tecnologie

## white cream



scheda  
tecnica



data  
sheet



ficha  
técnica



<p>idropittura traspirante effetto vellutato</p> <p><b>interno</b></p>	<p>breathable water-based paint with a velvety effect</p> <p><b>indoor</b></p>	<p>pintura al agua transpirante de efecto aterciopelado</p> <p><b>interiores</b></p>
<p>Idropittura con elevata copertura, alto riempimento e resa. Risulta di facile applicazione grazie all'ottima dilatazione e all'alto riempimento. Formulato a base di resine vinilversatiche in dispersione, pigmenti, cariche inerti e idrorepellenti, dotata di alcaliresistenza e traspirabilità. La Classe TVOC A+ lo rende idoneo per ottemperare ai protocolli CAM, -Leed Breeam. Per uso professionale.</p>	<p>Water-based paint with high coverage, high filling and coverage. It is easy to apply thanks to its excellent expansion and high filling properties. Formulated with vinyl-versatic resins in dispersion, pigments, inert, water repellent mineral fillers. Provides good alkali resistance and breathability. Classified TVOC A+, it complies with Leed Breeam protocols. For professional use.</p>	<p>Pintura al agua con alta capacidad cubriente, de relleno y con gran rendimiento. Resulta fácil de aplicar gracias a la excelente dilatación y gran capacidad de relleno. Formulada a base de resinas vinilversáticas en dispersión, pigmentos, cargas inertes e hidro-repelentes, dotada de resistencia a los álcalis y transpirabilidad. La Clase TVOC A+ la hace idónea para cumplir con los protocolos Leed Breeam. Para uso profesional.</p>
<p><b>Attrezzatura:</b> pennello, rullo, airless <b>Diluizione:</b> acqua - 30% <b>Resa</b> (2 mani): 4-5 m<sup>2</sup>/l - Per confezione (14 l): 70 m<sup>2</sup> <b>Colore:</b> solo bianco</p>	<p><b>Equipment:</b> brush, roller, airless <b>Dilution:</b> water - 30% <b>Coverage</b> (2 coats): 4-5 m<sup>2</sup>/l - Per packaging (14 l): 70 m<sup>2</sup> <b>Color:</b> only white</p>	<p><b>Herramientas:</b> brocha, rodillo, pistola pulverizadora <b>Dilución:</b> agua - 30% <b>Rendimiento</b> (2 capas): 4-5 m<sup>2</sup>/l - Por envase (14 l): 70 m<sup>2</sup> <b>Color:</b> solo blanco</p>

tecniche	certificazioni	proprietà	tecnologie
WATER BASED BRUSH ROLLER AIRLESS		BREATHABLE COVERAGE BRILLIANCE	

## mural verde



scheda  
tecnica



data  
sheet



ficha  
técnica



<p>idropittura murale traspirante opaca</p> <p><b>interno</b></p>	<p>matt breathable water-based wall paint</p> <p><b>indoor</b></p>	<p>pintura al agua de pared transpirante mate</p> <p><b>interiores</b></p>
<p>Idropittura murale traspirante opaca a base di resine sintetiche vinilacriliche in dispersione acquosa, pigmenti selezionati, cariche minerali che gli conferiscono un alto grado di pienezza. Ideale come base per realizzare tinte chiare e pastello. Per uso professionale.</p>	<p>Matt breathable water-based wall paint based on synthetic vinyl-acrylic resins dispersed in water, selected pigments and mineral fillers that impart a high degree of fullness. Ideal as base with which to create light, pastel shades. For professional use.</p>	<p>Pintura al agua de pared transpirante mate a base de resinas sintéticas vinilacrilicas en dispersión acuosa, pigmentos seleccionados, cargas minerales que les proporcionan un gran cuerpo. Ideal como base para realizar tintes claros y pastel. Para uso profesional.</p>
<p><b>Attrezzatura:</b> pennello, rullo, airless <b>Diluizione:</b> acqua - 25-30% <b>Resa</b> (2 mani): 3,5-4,5 m<sup>2</sup>/l - Per confezione (14 l): 63 m<sup>2</sup> <b>Colore:</b> bianco e colorato</p>	<p><b>Equipment:</b> brush, roller, airless <b>Dilution:</b> water - 25-30% <b>Coverage</b> (2 coats): 3,5-4,5 m<sup>2</sup>/l - Per packaging (14 l): 63 m<sup>2</sup> <b>Color:</b> white and colored</p>	<p><b>Herramientas:</b> brocha, rodillo, pistola pulverizadora <b>Dilución:</b> agua - 25-30% <b>Rendimiento</b> (2 capas): 3,5-4,5 m<sup>2</sup>/l - Por envase (14 l): 63 m<sup>2</sup> <b>Color:</b> blanco y colorado</p>

tecniche	certificazioni	proprietà	tecnologie
YOU COLOR COLOURABLE WATER BASED BRUSH ROLLER AIRLESS		BREATHABLE COVERAGE BRILLIANCE	



# pitture

**pitture per interno**

# prodotti

mural blu

pittura per interni extra

biancocalce

bianco interno

idroflex matt

idroflex gloss

idrofumo







## mural blu

scheda  
tecnicadata  
sheetficha  
técnica







idropittura murale traspirante coprente	<b>interno</b>	opaque breathable water-based wall paint	<b>indoor</b>	pittura al acqua de pared traspirante cubriente	<b>interiores</b>
Idropittura murale traspirante coprente a base di resine viniliche dotata di ottima copertura e buon punto di bianco. Monocomponente ad essiccamento fisico ideale per rinnovare ed uniformare pareti bianche con un buon risultato estetico. Per uso professionale.		Opaque breathable water-based paint containing vinyl resins for superb coverage and good whiteness. One-pack, physical drying product ideal for renovations and attractively smoothing out white walls. For professional use.		Pintura al agua de pared traspirante cubriente a base de resinas vinílicas dotada de excelente capacidad cubriente y buen punto de blanco. Monocomponente de secado físico ideal para renovar y uniformar paredes blancas con un buen resultado estético. Para uso profesional.	
<b>Attrezzatura:</b> pennello, rullo, airless <b>Diluizione:</b> acqua - 30% <b>Resa</b> (2 mani): 3-4 m <sup>2</sup> /l - Per confezione (14 l): 56 m <sup>2</sup> <b>Colore:</b> solo bianco		<b>Equipment:</b> brush, roller, airless <b>Dilution:</b> water - 30% <b>Coverage</b> (2 coats): 3-4 m <sup>2</sup> /l - Per packaging (14 l): 56 m <sup>2</sup> <b>Color:</b> only white		<b>Herramientas:</b> brocha, rodillo, pistola pulverizadora <b>Dilución:</b> agua - 30% <b>Rendimiento</b> (2 capas): 3-4 m <sup>2</sup> /l - Por envase (14 l): 56 m <sup>2</sup> <b>Color:</b> solo blanco	

tecniche	certificazioni	proprietà	tecnologie
 WATER BASED  BRUSH  ROLLER  AIRLESS		 class 3 COVERAGE  V1 BREATHABLE  matt BRILLIANCE	

## pittura per interni extra

scheda  
tecnicadata  
sheetficha  
técnica

idropittura murale traspirante tinte tenui	<b>interno</b>	breathable water- based wall paint in soft colours	<b>indoor</b>	pittura al acqua de pared traspirante tintes tenues	<b>interiores</b>
Idropittura a base di resine vinilversatiche in dispersione acquosa appositamente studiata per ottimizzare l'applicazione a pennello e rullo e massima traspirabilità. Possibilità di realizzare colori tenui. Per uso professionale.		Water-based paint containing vinyl-versatic resins dispersed in water, specially designed to optimize application with brush and roller and achieve utmost breathability. Pastel colours can be produced. For professional use.		Pintura al agua a base de resinas vinilversáticas en dispersión acuosa expresamente estudiada para optimizar la aplicación con brocha y rodillo; máxima transpirabilidad. Posibilidad de realizar colores tenues. Para uso profesional.	
<b>Attrezzatura:</b> pennello, rullo, airless <b>Diluizione:</b> acqua - 15-20% <b>Resa</b> (2 mani): 3-4 m <sup>2</sup> /l - Per confezione (14 l): 56 m <sup>2</sup> <b>Colore:</b> bianco e colorato		<b>Equipment:</b> brush, roller, airless <b>Dilution:</b> water - 15-20% <b>Coverage</b> (2 coats): 3-4 m <sup>2</sup> /l - Per packaging (14 l): 56 m <sup>2</sup> <b>Color:</b> white and colored		<b>Herramientas:</b> brocha, rodillo, pistola pulverizadora <b>Dilución:</b> agua - 15-20% <b>Rendimiento</b> (2 capas): 3-4 m <sup>2</sup> /l - Por envase (14 l): 56 m <sup>2</sup> <b>Color:</b> blanco y colorido	

tecniche	certificazioni	proprietà	tecnologie
 WATER BASED  BRUSH  ROLLER  AIRLESS		 class 3 COVERAGE  V1 BREATHABLE  matt BRILLIANCE	

## biancocalce



scheda  
tecnica



data  
sheet



ficha  
técnica



pittura a base di grassello di calce	interno	lime putty -based paint	indoor	pittura a base de masilla de cal	interiores
Pittura minerale formulata con grassello di calce e carbonati micronizzati. La pittura risulta particolarmente idonea per tinteggiare ambienti interni di carattere storico monumentale e per tutte le murature minerali di nuova costruzione. Per uso professionale.		Mineral-based paint containing lime putty and micronised carbonates. The paint is ideal for interior walls in historic buildings-monuments and for all newly-built mineral walls. For professional use.		Pintura mineral formulada con masilla de cal y carbonatos micronizados. La pintura resulta particularmente idónea para dar tinte a espacios internos de carácter histórico monumental y para todas las paredes minerales de nueva construcción. Para uso profesional.	
<b>Attrezzatura:</b> pennello, rullo, airless <b>Diluizione:</b> acqua - pennello, rullo: 20-30% - airless: 30-35% <b>Resa</b> (2 mani): 3-3,5 m <sup>2</sup> /l - Per confezione (14 l): 49 m <sup>2</sup> <b>Colore:</b> solo bianco		<b>Equipment:</b> brush, roller, airless <b>Dilution:</b> water - brush, roller: 20-30% - airless: 30-35% <b>Coverage</b> (2 coats): 3-3,5 m <sup>2</sup> /l - Per packaging (14 l): 49 m <sup>2</sup> <b>Color:</b> only white		<b>Herramientas:</b> brocha, rodillo, pistola pulverizadora <b>Dilución:</b> agua - brocha, rodillo: 20-30% - pistola pulverizadora: 30-35% <b>Rendimiento</b> (2 capas): 3-3,5 m <sup>2</sup> /l - Por envase (14 l): 49 m <sup>2</sup> <b>Color:</b> solo blanco	

tecniche	certificazioni	proprietà	tecnologie
WATER BASED BRUSH ROLLER AIRLESS		class 4 COVERAGE V1 BREATHABLE matt BRILLIANCE	

## bianco interno



scheda  
tecnica



data  
sheet



ficha  
técnica



idropittura murale coprente opaca	interno	opaque water-based wall paint	indoor	pittura al acqua de pared cubriente mate	interiores
Idropittura murale coprente opaca a base di resine vinilversatiche, in dispersione acquosa, cariche inerti; unisce una buona resa a un'ottima facilità di applicazione. Particolarmente adatto alla pitturazione di grandi metrature e cantieristica. Per uso professionale.		Opaque water-based wall paint with vinyl-versatic resins dispersed in water and inert fillers; combines good coverage with easy application. Particularly suitable for painting large areas and use in construction sites. For professional use.		Pintura al agua de pared cubriente mate a base de resinas vinilversáticas, en dispersión acuosa, cargas inertes; une un buen rendimiento a una excelente facilidad de aplicación. Particularmente idónea para pintar grandes superficies y en obras. Para uso profesional.	
<b>Attrezzatura:</b> pennello, rullo, airless <b>Diluizione:</b> acqua - 40% <b>Resa</b> (2 mani): 3-4 m <sup>2</sup> /l - Per confezione (14 l): 56 m <sup>2</sup> <b>Colore:</b> solo bianco		<b>Equipment:</b> brush, roller, airless <b>Dilution:</b> water - 40% <b>Coverage</b> (2 coats): 3-4 m <sup>2</sup> /l - Per packaging (14 l): 56 m <sup>2</sup> <b>Color:</b> only white		<b>Herramientas:</b> brocha, rodillo, pistola pulverizadora <b>Dilución:</b> agua - 40% <b>Rendimiento</b> (2 capas): 3-4 m <sup>2</sup> /l - Por envase (14 l): 56 m <sup>2</sup> <b>Color:</b> solo blanco	

tecniche	certificazioni	proprietà	tecnologie
WATER BASED BRUSH ROLLER AIRLESS		class 4 COVERAGE V1 BREATHABLE matt BRILLIANCE	

## idrofless matt

scheda  
tecnicadata  
sheetficha  
técnica

Idropittura a spessore plastico bucciato	<b>interno</b>	thick plastic water- based paint with orange-peel finish	<b>indoor</b>	pittura al agua de espesor plástico moteado	<b>interiores</b>
Idro Idropittura a spessore plastico bucciato a base di resine copolimeriche in dispersione acquosa, cariche specifiche selezionate di granulometria grossolana. Permette di ottenere il tradizionale effetto bucciato. Per uso professionale.		Thick plastic water-based paint with orange-peel finish containing copolymer resins dispersed in water and specific coarse-grained fillers. Makes it possible to obtain the traditional orange-peel effect. For professional use.		Pintura al agua de espesor plástico moteado a base de resinas copoliméricas en dispersión acuosa, cargas específicas seleccionadas de granulometría gruesa. Permite obtener el tradicional efecto moteado. Para uso profesional.	
<b>Attrezzatura:</b> pennello, rullo a nido d'ape, rullo di spugna <b>Diluizione:</b> pronto all'uso <b>Resa</b> (2 mani): 2 m <sup>2</sup> /l - Per confezione (14 l): 28 m <sup>2</sup> <b>Colore:</b> bianco e colorato		<b>Equipment:</b> brush, honeycomb roller, sponge roller <b>Dilution:</b> ready to use <b>Coverage</b> (2 coats): 2 m <sup>2</sup> /l - Per packaging (14 l): 28 m <sup>2</sup> <b>Color:</b> white and colored		<b>Herramientas:</b> brocha, rodillo de alveolos, rodillo de esponja <b>Dilución:</b> listo para usar <b>Rendimiento</b> (2 capas): 2 m <sup>2</sup> /l - Por envase (14 l): 28 m <sup>2</sup> <b>Color:</b> blanco y colorido	

tecniche	certificazioni	proprietà	tecnologie
 WATER BASED  BRUSH  ROLLER  READY TO USE		 satin BRILLIANCE  S3 WASHABLE  matt BRILLIANCE	 resistance 4

## idrofless gloss

scheda  
tecnicadata  
sheetficha  
técnica

idropittura a spessore plastico lavabile	<b>interno</b>	thick plastic washable water-based paint	<b>indoor</b>	pittura al agua de espesor plástico lavabile	<b>interiores</b>
Idropittura a spessore plastico lavabile a base di resine vinilversatiche in dispersione acquosa e cariche minerali, riempitivi selezionati. Idoneo per ottenere film a spessore in mano unica con effetto lucido. Per uso professionale.		Thick plastic washable water-based paint with vinyl-versatic resins and mineral fillers dispersed in water, selected fillers. Suitable for obtaining thick, glossy films in a single coat. For professional use.		Pintura al agua de espesor plástico lavable a base de resinas vinilversáticas en dispersión acuosa, cargas minerales y rellenos seleccionados. Idóneo para obtener una película de espesor en una sola mano con efecto brillante. Para uso profesional.	
<b>Attrezzatura:</b> pennello, rullo di gomma <b>Diluizione:</b> pronto all'uso <b>Resa</b> (2 mani): 2 m <sup>2</sup> /l - Per confezione (14 l): 28 m <sup>2</sup> <b>Colore:</b> bianco e colorato		<b>Equipment:</b> brush, rubber roller <b>Dilution:</b> ready to use <b>Coverage</b> (2 coats): 2 m <sup>2</sup> /l - Per packaging (14 l): 28 m <sup>2</sup> <b>Color:</b> white and colored		<b>Herramientas:</b> brocha, rodillo de goma <b>Dilución:</b> listo para usar <b>Rendimiento</b> (2 capas): 2 m <sup>2</sup> /l - Por envase (14 l): 28 m <sup>2</sup> <b>Color:</b> blanco y colorido	

tecniche	certificazioni	proprietà	tecnologie
 WATER BASED  BRUSH  ROLLER  READY TO USE		 S3 WASHABLE  gloss BRILLIANCE	 resistance 4

# idrofumo



scheda  
tecnica



data  
sheet



ficha  
técnica



pittura opaca antifumo	interno	matt smoke suppressant paint	indoor	pintura mate antihumo	interiores
<p>Pittura lavabile opaca antifumo con un elevato grado di copertura. Formulata a base di resine acriliche in dispersione acquosa e cariche minerali speciali che la rendono idonea a trattare ambienti con ingiallimenti dovuti a fumo e fuliggine. La sua formulazione garantisce la non ricomparsa di macchie di nicotina, nerofumo, fuliggine. Inodore. Per uso professionale</p> <p><b>Attrezzatura:</b> pennello per le impregnazioni, rullo o airless se utilizzato come finitura  <b>Diluizione:</b> acqua - 20%  <b>Resa</b> (2 mani): 5 m<sup>2</sup>/l - Per confezione (14 l): 70 m<sup>2</sup>  <b>Colore:</b> solo bianco</p>		<p>Matt, washable smoke suppressant paint with high coverage. Formulated with acrylic resins dispersed in water and special mineral fillers that make it suitable for treating environments subject to yellowing due to smoke and soot. Its formulation ensures that the stains of nicotine, carbon black and soot will not reappear. Odourless. For professional use.</p> <p><b>Equipment:</b> brush for impregnation, roller or airless if used as a finishing  <b>Dilution:</b> water - 20%  <b>Coverage</b> (2 coats): 5 m<sup>2</sup>/l - Per packaging (14 l): 70 m<sup>2</sup>  <b>Color:</b> only white</p>		<p>Pintura lavable mate antihumo de alta capacidad cubriente. Formulada a base de resinas acrílicas en dispersión acuosa y cargas minerales especiales que la hacen idónea para tratar espacios con amarilleo debido al humo y el hollín. Su formulación garantiza que no vuelvan a aparecer las manchas de nicotina, el negro de humo, el hollín. Inodoro. Para uso profesional.</p> <p><b>Herramientas:</b> brocha, rodillo o pistola pulverizadora  <b>Dilución:</b> agua - 20%  <b>Rendimiento</b> (2 capas): 5 m<sup>2</sup>/l - Por envase (14 l): 70 m<sup>2</sup>  <b>Color:</b> solo blanco</p>	

tecniche				certificazioni				proprietà			tecnologie			
														
WATER BASED	BRUSH	ROLLER	AIRLESS					WASHABLE	COVERAGE	BRILLIANCE				

# Vita San



**vita sa**



# prodotti

vita bianca  
 vita wash  
 vita therm  
 primer therm  
 sana rasothersm  
 sana finish  
 sana bianca  
 sanasil-bio  
 sana solux  
 sana solux spray  
 espositore prodotti  
 totem promozionale  
 sana salute gel  
 sana salute spray  
 sana salute pro indoor  
 sana salute pro outdoor  
 sana salute oxy  
 sana salute sprayer pump  
 colonna porta gel

# a

## Pitture Ecologiche

Ipoallergeniche Anti-condensa  
 Anti-formaldeide  
 Dermatologicamente Testate

## Soluzioni Sanitizzanti

Termiche Igienizzanti  
 Anti-muffa per il Benessere  
 e il Comfort Abitativo

## Igienizzanti Virus-stop

per la sanificazione di mani  
 utensili ponteggi  
 superfici interne ed esterne

# na



## vita bianca

scheda  
tecnicadata  
sheetficha  
técnica

idroittura traspirante ipoallergenica	interno	hypoallergenic, breathable water-based paint	indoor	pintura al agua traspirante hipoalergénica	interiores
<p>Idroittura traspirante ipoallergenica super copertura con elevato punto di bianco. Formulata con materie non pericolose ed adatta ad ambienti frequentati da soggetti sensibili ad allergie come certificato rapporto di Prova N°263/14/04 (ISPE). L'azione disgregante di aldeidi è certificato dall'Istit. Giordano N°326956. La Classe TVOC A+ lo rende idoneo per ottemperare ai protocolli CAM, Leed Breeam. Per uso professionale.</p>		<p>Hypoallergenic, breathable water-based paint offering superb coverage and high whiteness. Formulated with materials that are harmless to humans, suitable for rooms accommodating allergy sufferers, as certified by Test Report No. 263/14/04 (ISPE). The disruptive action of aldehydes is certified by Istituto Giordano certificate No. 326956. Classified TVOC A+, it complies with Leed Breeam protocols. For professional use.</p>		<p>Pintura al agua traspirante hipoalergénica con supercapacidad cubriente y elevado punto de blanco. Formulada con materias no peligrosas e idónea para espacios frecuentados por sujetos sensibles a las alergias como se certifica en el informe de Prueba n.º 263/14/04 (ISPE). La acción disgregante de los aldehidos está certificada por el Instituto Giordano N.º 326956. La Clase TVOC A+ la hace idónea para cumplir con los protocolos Leed Breeam. Para uso profesional.</p>	
<p><b>Attrezzatura:</b> pennello, rullo, airless <b>Diluizione:</b> acqua - 40-50% <b>Resa</b> (2 mani): 4-5 m<sup>2</sup>/l - Per confezione (12 l): 60 m<sup>2</sup> <b>Colore:</b> solo bianco</p>		<p><b>Equipment:</b> brush, roller, airless <b>Dilution:</b> water - 40-50% <b>Coverage</b> (2 coats): 4-5 m<sup>2</sup>/l - Per packaging (12 l): 60 m<sup>2</sup> <b>Color:</b> only white</p>		<p><b>Herramientas:</b> brocha, rodillo, pistola pulverizadora <b>Dilución:</b> agua - 40-50% <b>Rendimiento</b> (2 capas): 4-5 m<sup>2</sup>/l - Por envase (12 l): 60 m<sup>2</sup> <b>Color:</b> solo blanco</p>	

tecniche	certificazioni	proprietà	tecnologie
WATER BASED BRUSH ROLLER AIRLESS	A+ anallergico abbatte aldeidi	class 1 BREATHABLE BRILLIANCE	

## vita wash

scheda  
tecnicadata  
sheetficha  
técnica

idroittura lavabile ipoallergenica	interno	hypoallergenic, washable water-based paint	indoor	pintura al agua lavable hipoalergénica	interiores
<p>Idroittura lavabile ipoallergenica dermatologicamente testata con rapporto di prova N°263/14/04 (ISPE) che ne attesta la non pericolosità sull'uomo pertanto l'idoneità ad ambienti frequentati da soggetti sensibili ad allergie. L'azione disgregante di aldeidi è certificato dall'Istit. Giordano N°326956. La Classe TVOC A+ lo rende idoneo per ottemperare ai protocolli CAM, Leed Breeam. Per uso professionale.</p>		<p>Hypoallergenic, washable water-based paint dermatologically tested with test report No. 263/14/04 (ISPE) certifying that it is harmless to humans and thus suitable for rooms accommodating allergy sufferers. The disruptive action of aldehydes is certified by Istituto Giordano certificate No. 326956. Classified TVOC A+, it complies with Leed Breeam protocols. For professional use.</p>		<p>Pintura al agua lavable hipoalergénica dermatologicamente testada con informe de prueba N.º 263/14/04 (ISPE) que certifica la no peligrosidad para el hombre, y por tanto la idoneidad para espacios frecuentados por sujetos sensibles a las alergias. La acción disgregante de los aldehidos está certificada por el Instituto Giordano N.º 326956. La Clase TVOC A+ la hace idónea para cumplir con los protocolos Leed Breeam. Para uso profesional.</p>	
<p><b>Attrezzatura:</b> pennello, rullo, airless <b>Diluizione:</b> acqua - 15-20% <b>Resa</b> (2 mani): 4-5 m<sup>2</sup>/l - Per confezione (12 l): 60 m<sup>2</sup> <b>Colore:</b> bianco e colorato</p>		<p><b>Equipment:</b> brush, roller, airless <b>Dilution:</b> water - 15-20% <b>Coverage</b> (2 coats): 4-5 m<sup>2</sup>/l - Per packaging (12 l): 60 m<sup>2</sup> <b>Color:</b> white and colored</p>		<p><b>Herramientas:</b> brocha, rodillo, pistola pulverizadora <b>Dilución:</b> agua - 15-20% <b>Rendimiento</b> (2 capas): 4-5 m<sup>2</sup>/l - Por envase (12 l): 60 m<sup>2</sup> <b>Color:</b> blanco y colorido</p>	

tecniche	certificazioni	proprietà	tecnologie
YOU COLOR WATER BASED BRUSH ROLLER AIRLESS	A+ anallergico abbatte aldeidi	class 2 S3 V2 BRILLIANCE	

## vita therm



scheda  
tecnica



data  
sheet



ficha  
técnica

idropittura traspirante anticondensa	<b>interno</b>	breathable water-based anti-condensation paint	<b>indoor</b>	pintura al agua transpirante anticondensación	<b>interiores</b>
<p>Idropittura traspirante anticondensa ipoallergenica dermatologicamente testata con rapporto di prova N°263/14/04(ISPE) che ne attesta la non pericolosità sull'uomo pertanto l'idoneità ad ambienti frequentati da soggetti sensibili ad allergie. L'azione disgregante di aldeidi è certificato dall'Istit. Giordano N°326956. La Classe TVOC A+ lo rende idoneo per ottemperare ai protocolli CAM, Leed Breeam. Per uso professionale.</p>		<p>Breathable hypoallergenic water-based anti-condensation paint dermatologically tested with test report No. 263/14/04 (ISPE) certifying that it is harmless to humans and thus suitable to rooms accommodating allergy sufferers. The disruptive action of aldehydes is certified by Istituto Giordano certificate No. 326956. Classified TVOC A+, it complies with Leed Breeam protocols. For professional use.</p>		<p>Pintura al agua al agua transpirante anticondensación ipoalergénica dermatológicamente testada con informe de prueba N.º 263/14/04(ISPE) que certifica la no peligrosidad para el hombre, y por tanto la idoneidad para espacios frecuentados por sujetos sensibles a las alergias. La acción disgregante de los aldehídos está certificada por el Instituto Giordano N.º 326956. La Clase TVOC A+ la hace idónea para cumplir con los protocolos Leed Breeam. Para uso profesional.</p>	
<p><b>Attrezzatura:</b> pennello, rullo, airless <b>Diluizione:</b> acqua - 5-10%; airless 15-20% <b>Resa</b> (2 mani): 3-3,5 m<sup>2</sup>/l - Per confezione (12 l): 42 m<sup>2</sup> <b>Colore:</b> solo bianco</p>		<p><b>Equipment:</b> brush, roller, airless <b>Dilution:</b> water - 5-10%; airless 15-20% <b>Coverage</b> (2 coats): 3-3,5 m<sup>2</sup>/l - Per packaging (12 l): 42 m<sup>2</sup> <b>Color:</b> only white</p>		<p><b>Herramientas:</b> brocha, rodillo, pistola pulverizadora <b>Dilución:</b> agua - 5-10%; pistola pulverizadora 15-20% <b>Rendimiento</b> (2 capas): 3-3,5 m<sup>2</sup>/l - Por envase (12 l): 42 m<sup>2</sup> <b>Color:</b> solo blanco</p>	

<b>tecniche</b>	<b>certificazioni</b>	<b>proprietà</b>	<b>tecnologie</b>
WATER BASED BRUSH ROLLER AIRLESS	A+ anallergico abbatte aldeidi	V1 BREATHABLE BRILLIANCE ANTI CONDENSATION	

## primer therm



scheda  
tecnica



data  
sheet



ficha  
técnica

fissativo acrilico	<b>interno</b>	acrylic fixative	<b>indoor</b>	fijador acrílico	<b>interior</b>
<p>Fissativo acrilico all'acqua pigmentato, ad alto potere penetrante, idoneo per supporti leggermente assorbenti o sforinanti, particolarmente attivo in sinergia con Vita Therm per prevenire l'annerimento da muffe in parete. Per uso professionale.</p>		<p>Water-based pigmented acrylic fixative with great penetrating properties, suitable for slightly absorbent and chalky substrates. Particularly active with Vita Therm to prevent wall blackening due to mould. For professional use.</p>		<p>Fijador acrílico al agua, pigmentado, de alto poder penetrante, idóneo para soportes ligeramente absorbentes o con desintegración pulverulenta, particularmente activo en sinergia con el producto Vita Therm para prevenir el ennegrecimiento causado por mohos en la pared. Para uso profesional.</p>	
<p><b>Attrezzatura:</b> pennello, rullo, airless <b>Diluizione:</b> acqua - 500% <b>Resa</b> (2 mani): 6-8 m<sup>2</sup>/l - Per confezione (12 l): 96 m<sup>2</sup> <b>Colore:</b> solo bianco</p>		<p><b>Equipment:</b> brush, roller, airless <b>Dilution:</b> water - 500% <b>Coverage</b> (2 coats): 6-8 m<sup>2</sup>/l - Per packaging (12 l): 96 m<sup>2</sup> <b>Color:</b> only white</p>		<p><b>Herramientas:</b> brocha, rodillo, pistola pulverizadora <b>Dilución:</b> agua - 500% <b>Rendimiento</b> (2 capas): 6-8 m<sup>2</sup>/l - Por envase (12 l): 96 m<sup>2</sup> <b>Color:</b> solo blanco</p>	

<b>tecniche</b>	<b>certificazioni</b>	<b>proprietà</b>	<b>tecnologie</b>
WATER BASED BRUSH ROLLER AIRLESS			

## sana rasotherm

 scheda  
tecnica

 data  
sheet

 ficha  
técnica

rasante termico anticondensa	interno	anti-condensation thermal skim coat	indoor	enrasado térmico anticondensación	interiores
<p>Rasante e intonaco in pasta con elevate proprietà termoisolanti a base di sfere di vetro cave e materie prime ad alta resistenza termica in grado di conferire al prodotto un valore di lambda estremamente basso. Migliora e riduce formazione di condensa superficiale con relativo sviluppo di muffe. Per uso professionale.</p>		<p>Skim coat and plaster in paste form with high thermal insulating properties based on hollow glass beads and high thermal resistant raw materials that give the product an extremely low lambda value. It improves performance and reduces the formation of surface condensation, preventing the development of mould and mildew. For professional use.</p>		<p>Enrasado y enfoscado en pasta con elevadas propiedades termoisolantes a base de bolas de vidrio huecas y materias primas de alta resistencia térmica capaces de conferir al producto un valor de lambda extremadamente bajo. Mejora y reduce la formación de condensación superficial con desarrollo de mohos. Para uso profesional.</p>	
<p><b>Attrezzatura:</b> frattazzo dentato (denti da 12 mm), frattazzo metallico, spatola abrasiva <b>Diluizione:</b> acqua - pronto all'uso <b>Resa:</b> 6 l/m<sup>2</sup> per 6 mm di spessore <b>Colore:</b> solo bianco</p>		<p><b>Equipment:</b> toothed trowel (12 mm teeth), metal trowel, abrasive coat spatula <b>Dilution:</b> water - ready to use <b>Coverage:</b> 6 l/m<sup>2</sup> per 6 mm of thickness <b>Color:</b> only white</p>		<p><b>Herramientas:</b> llana dentada (dientes de 12 mm), llana metálica, espátula abrasiva <b>Dilución:</b> agua - listo para usar <b>Rendimiento:</b> 6 l/m<sup>2</sup> por 6 mm de espesor <b>Color:</b> solo blanco</p>	

tecniche	certificazioni	proprietà	tecnologie
WATER BASED TROWEL READY TO USE		BREATHABLE	

## sana finish

 scheda  
tecnica

 data  
sheet

 ficha  
técnica

rasante di finitura a civile	interno esterno	skim coat with two- coat finish	indoor outdoor	enrasado para acabado de revoco	interior exterior
<p>Rasatura a grana fine idonea per rasare intonaci cementizi vecchi (non sfarinanti) e nuovi. Lo spessore massimo per singola mano è di 3 mm; per ottenere spessori maggiori è necessario inserire tra la prima e la seconda mano una rete in fibra di vetro. Studiato come finitura a civile di Sana Rasotherm nel ciclo "Vita Sana". Per uso professionale.</p>		<p>Fine-grained skim coat suitable for smoothing out old (non-flaking) and new cement-based plasters. The maximum thickness of a single coat is 3 mm; greater thicknesses require installing a glass fibre mesh between the first and second coat. Designed as a two-coat finish for Sana Rasotherm used in the "Vita Sana" process. For professional use.</p>		<p>Enrasado de grano fino idóneo para enrasar enfoscados de cemento viejos (sin desintegración pulverulenta) y nuevos. El espesor máximo para una sola mano es de 3 mm; para obtener espesores mayores es necesario interponer una malla de fibra de vidrio. Estudiado como acabado de revoco de Sana Rasotherm en el ciclo "Vita Sana" Para uso profesional.</p>	
<p><b>Attrezzatura:</b> spatola <b>Rapporto di miscelazione:</b> acqua - 24-25% <b>Resa:</b> 1,5 kg/m<sup>2</sup> per mm di spessore <b>Colore:</b> solo bianco</p>		<p><b>Equipment:</b> spatula <b>Mixing ratio:</b> water - 24-25% <b>Coverage:</b> 1,5 kg/m<sup>2</sup> per mm of thickness <b>Color:</b> only white</p>		<p><b>Herramientas:</b> espátula <b>Proporción de mezcla:</b> agua - 24-25% <b>Rendimiento:</b> 1,5 kg/m<sup>2</sup> per mm de espesor <b>Color:</b> solo blanco</p>	

tecniche	certificazioni	proprietà	tecnologie
WATER BASED TROWEL		BREATHABLE	

## sana bianca

 scheda  
tecnica

 data  
sheet

 ficha  
técnica

idropittura traspirante antimuffa	interno	breathable water- based paint	indoor	pittura al acqua traspirante	interiores
<p>Idropittura traspirante opaca a base di resine acriliche. La sua efficacia contro l'annerimento dovuto all'attacco di funghi e muffe è certificata dal documento N° 537/I eseguito dai laboratori di ricerca della GFC chimica. Per uso professionale.</p>		<p>Matt breathable water-based paint with acrylic resins. Its effectiveness against the blackening produced by mould and mildew is certified by document No. 537/I issued by the GFC Chimica research laboratories. For professional use.</p>		<p>Pittura al acqua traspirante mate a base de resinas acrilicas. Su eficacia contra el ennegrecimiento debido al ataque de hongos y mohos se certifica con el documento n.º 537/I realizado por los laboratorios de investigación de GFC química. Para uso profesional.</p>	
<p><b>Attrezzatura:</b> pennello, rullo <b>Diluizione:</b> acqua - 15-20% <b>Resa</b> (2 mani): 4-5 m<sup>2</sup>/l - Per confezione (12 l): 60 m<sup>2</sup> <b>Colore:</b> bianco e colorato</p>		<p><b>Equipment:</b> brush, roller <b>Dilution:</b> water - 15-20% <b>Coverage</b> (2 coats): 4-5 m<sup>2</sup>/l - Per packaging (12 l): 60 m<sup>2</sup> <b>Color:</b> white and colored</p>		<p><b>Herramientas:</b> brocha, rodillo <b>Dilución:</b> agua - 15-20% <b>Rendimiento</b> (2 capas): 4-5 m<sup>2</sup>/l - Por envase (12 l): 60 m<sup>2</sup> <b>Color:</b> blanco y colorido</p>	

tecniche	certificazioni	proprietà	tecnologie
COLOURABLE WATER BASED BRUSH ROLLER	muffe batteri	class 2 BREATHABLE BRILLIANCE	

## sanasil-bio



scheda  
tecnica



data  
sheet



ficha  
técnica



idropittura traspirante a base silicati	<b>interno</b>	breathable water-based paint with silicates	<b>indoor</b>	pintura al agua transpirante a base de silicatos	<b>interior</b>
<p>Idropittura a base silicati, conforme alle normative DIN EN 13300 e DIN 18363 per il contenuto di sostanze organiche. Assicura traspirabilità al vapore, idrorepellenza e copertura. Formulata con bassissimo VOC e a film protetto dall'attacco di muffe e microorganismi. Per uso professionale.</p>		<p>Water-based paint containing silicates, compliant with DIN EN 13300 and DIN 18363 given its content of organic substances. Vapour permeable, water repellent, washable, it also provides good coverage. Formulated with very low VOC; film protected from the attack of mould and microorganisms. For professional use.</p>		<p>Pintura al agua a base de silicatos, conforme a las normativas DIN EN 13300 y DIN 18363 para el contenido de sustancias orgánicas. Asegura transpirabilidad al vapor, capacidad hidro-repelente y cubriente. Formulada con bajísimo VOC y en película protegida del ataque de mohos y microorganismos. Para uso profesional.</p>	
<p><b>Attrezzatura:</b> pennello, rullo, spruzzo <b>Diluizione:</b> acqua distillata - 20-30% <b>Resa</b> (2 mani): 4-4,5 m<sup>2</sup>/l - Per confezione (12 l): 54 m<sup>2</sup> <b>Colore:</b> solo bianco</p>		<p><b>Equipment:</b> brush, roller, airless <b>Dilution:</b> distilled water - 20-30% <b>Coverage</b> (2 coats): 4-4,5 m<sup>2</sup>/l - Per packaging (12 l): 54 m<sup>2</sup> <b>Color:</b> only white</p>		<p><b>Herramientas:</b> brocha, rodillo, pistola pulverizadora <b>Dilución:</b> agua distillata - 20-30% <b>Rendimiento</b> (2 capas): 4-4,5 m<sup>2</sup>/l - Por envase (12 l): 54 m<sup>2</sup> <b>Color:</b> solo blanco</p>	

<b>tecniche</b>	<b>certificazioni</b>	<b>proprietà</b>	<b>tecnologie</b>
WATER BASED BRUSH ROLLER AIRLESS	muffe batteri	class 3 COVERAGE V1 BREATHABLE MINERAL matt BRILLIANCE	silicate 5

## sana solux



scheda  
tecnica



data  
sheet



ficha  
técnica



soluzione murale igienizzante	<b>interno esterno</b>	sanitising wall solution	<b>indoor outdoor</b>	solución de pared desinfectante	<b>interior exterior</b>
<p>Soluzione acquosa a base di particolari additivi indicata come igienizzante per supporti diversi con forte presenza di muffe, funghi e alghe. Per uso professionale.</p>		<p>Water-based solution containing special additives to be used as sanitiser for various substrates with an intense presence of mould, fungi and algae. For professional use.</p>		<p>Solución acuosa a base de aditivos particulares indicada como desinfectante de distintos soportes con presencia abundante de mohos, hongos y algas. Para uso profesional.</p>	
<p><b>Attrezzatura:</b> pennello, rullo, spruzzo <b>Diluizione:</b> acqua - 400% <b>Resa prodotto diluito (1 mano):</b> 40 m<sup>2</sup>/l - per confezione (5 l): 250 m<sup>2</sup> ca <b>Colore:</b> incolore</p>		<p><b>Equipment:</b> brush, roller, airless <b>Dilution:</b> water - 400% <b>Coverage</b> (1 coat diluted product): 40 m<sup>2</sup>/l - per packaging (5 l): 250 m<sup>2</sup> ca <b>Color:</b> colourless</p>		<p><b>Herramientas:</b> brocha, rodillo, pistola pulverizadora <b>Dilución:</b> agua - 400% <b>Rendimiento</b> (1 mano producto diluido): 40 m<sup>2</sup>/l - Por envase (5 l): 250 m<sup>2</sup> ca <b>Color:</b> incolore</p>	

<b>tecniche</b>	<b>certificazioni</b>	<b>proprietà</b>	<b>tecnologie</b>
WATER BASED BRUSH ROLLER AIRLESS	alghe muffe funghi		

## sana solux spray



scheda  
tecnica



data  
sheet



ficha  
técnica



soluzione igienizzante	<b>interno esterno</b>	sanitising solution	<b>indoor outdoor</b>	solución desinfectante	<b>interior exterior</b>
<p>Soluzione acquosa igienizzante a base di principi attivi specifici per bonificare e risanare supporti murari con forte presenza di muffe, funghi e alghe. Per uso professionale.</p>		<p>Water-based sanitisation solution containing specific active ingredients to clean and restore masonry substrates with an intense presence of mould, fungi and algae. For professional use.</p>		<p>Solución acuosa desinfectante a base de principios activos específicos para el saneamiento y reacondicionamiento de soportes de pared con presencia abundante de mohos, hongos y algas. Para uso profesional.</p>	
<p><b>Diluizione:</b> pronto all'uso <b>Resa</b> (1 mano): 10 m<sup>2</sup>/l - Per confezione (0,500 l): 5 m<sup>2</sup></p>		<p><b>Dilution:</b> ready to use <b>Coverage</b> (1 coat): 10 m<sup>2</sup>/l - Per packaging (0,500 l): 5 m<sup>2</sup></p>		<p><b>Dilución:</b> listo para usar <b>Rendimiento</b> (1 capa): 10 m<sup>2</sup>/l - Por envase (0,500 l): 5 m<sup>2</sup></p>	

<b>tecniche</b>	<b>certificazioni</b>	<b>proprietà</b>	<b>tecnologie</b>
WATER BASED READY TO USE			

## espositore prodotti vita sana



	interno	indoor	interiores
	Espositore in cartonato, personalizzato Vita Sana, a 4 ripiani.	Life Sana custom cardboard display, with 4 shelves.	Expositor de cartón, personalizado Vita Sana, con 4 estantes.
<b>Misure:</b>	larghezza cm 114 altezza cm 215 profondità cm 37	<b>Measures:</b> width cm 114 height cm 215 depth cm 37	<b>Medidas:</b> ancho 114 cm altura 215 cm profundidad 37 cm

## totem promozionale vita sana



	interno	indoor	interiores
	Totem espositivo promozionale, personalizzato Vita Sana, bifacciale in cartone a forma ellittica, completo di alette interne.	Promotional exhibition totem, custom Vista Sana, two-sided cardboard elliptical, complete with internal fins.	Tótem de exhibición promocional, Vista Sana personalizado, doble cara en cartón con forma elíptica, completo con solapas internas.
<b>Misure:</b>	larghezza cm 70 altezza cm 197 profondità cm 25	<b>Measures:</b> width cm 70 height cm 197 depth cm 25	<b>Medidas:</b> ancho 70 cm altura 197 cm profundidad 25 cm





## sana salute gel

 scheda  
tecnica

 data  
sheet

 ficha  
técnica

gel igienizzante mani	hand sanitiser	gel desinfectante para las manos
<p>Gel igienizzante mani realizzato con ingredienti che rispettano il film idrolipidico della pelle e che rilasciano una piacevole sensazione di idratazione sulle mani, è pratico da usare in ogni situazione. La sua particolare formula in gel permette una rapida azione ed un utilizzo senz'acqua. Conforme alla circolare del ministero della salute n° 5433 del 22/02/2020. Per uso professionale.</p>	<p>Hand sanitising gel made with ingredients that preserve the hydrolipidic film of the skin, imparting a pleasant, moisturising sensation. Practical for use in any situation. Its special gel formula ensures fast action and requires no water. Complies with Italian Ministry of Health Circular No. 5433 dated 22/02/2020. For professional use.</p>	<p>Gel desinfectante para las manos realizado con ingredientes que respetan la película hidrolipídica de la piel y que proporcionan una agradable sensación de hidratación en las manos, de uso práctico en toda situación. Su particular fórmula en gel permite una acción rápida y su uso sin agua. Conforme a la circular del ministerio de sanidad italiano n.º 5433 del 22/02/2020. Para uso profesional.</p>
<p><b>Diluizione:</b> pronto all'uso <b>Colore:</b> incolore</p>	<p><b>Dilution:</b> ready to use <b>Color:</b> colourless</p>	<p><b>Dilución:</b> listo para usar <b>Color:</b> incoloro</p>

tecniche	certificazioni	proprietà	tecnologie

## sana salute spray

 scheda  
tecnica

 data  
sheet

 ficha  
técnica

igienizzante per attrezzature	equipment sanitiser	desinfectante para herramientas
<p>Igienizzante per attrezzature svolge sulle superfici un'efficace azione igienizzante, evaporando rapidamente senza lasciare traccia. Impiegabile su superfici, mobili, oggetti e attrezzature sensibili all'acqua. Risciacquare le superfici trattate che vanno a contatto con gli alimenti. Pronto all'uso. Conforme alla circolare del ministero della salute n° 5433 del 22/02/2020. Per uso professionale.</p>	<p>Equipment sanitiser to effectively sanitise surfaces. It evaporates quickly without leaving a trace. Suitable for use on surfaces such as furniture, objects and equipment that are sensitive to water. Rinse any treated surfaces that come into contact with food-stuffs. Ready to use. Complies with Italian Ministry of Health Circular No. 5433 dated 22/02/2020. For professional use.</p>	<p>Desinfectante para herramientas; ejerce en las superficies una eficaz acción desinfectante; se evapora rápidamente sin dejar rastro. Puede emplearse sobre superficies muebles, objetos y herramientas sensibles al agua. Enjuagar las superficies tratadas que entren en contacto con los alimentos. Listo para usar. Conforme a la circular del ministerio de sanidad italiano n.º 5433 del 22/02/2020. Para uso profesional.</p>
<p><b>Diluizione:</b> pronto all'uso <b>Colore:</b> incolore</p>	<p><b>Dilution:</b> ready to use <b>Color:</b> colourless</p>	<p><b>Dilución:</b> listo para usar <b>Color:</b> incoloro</p>

tecniche	certificazioni	proprietà	tecnologie

## sana salute pro indoor

 scheda  
tecnica

 data  
sheet

 ficha  
técnica

detergente igienizzante per superfici interne	interno	sanitising detergent for indoor surfaces	indoor	detergente desinfectante para superficies interiores	interiores
<p>Detergente igienizzante per superfici interne particolarmente efficace per pulire pavimenti, sanitari, rubinetterie, bidoni dei rifiuti e superfici lucide e perfettamente deterse. Viene normalmente utilizzato ovunque ci siano esigenze di pulizia radicale eliminando anche eventuali cattivi odori. Conforme alla circolare del ministero della salute n° 5433 del 22/02/2020. Per uso professionale.</p>		<p>Sanitising detergent for indoor surfaces that is particularly effective for cleaning floors, bathroom fixtures, taps, garbage cans and shiny, perfectly clean surfaces. It is normally used whenever radical cleaning is needed while also eliminating any unpleasant odours. Complies with Italian Ministry of Health Circular No. 5433 dated 22/02/2020. For professional use.</p>		<p>Detergente desinfectante para superficies interior particolarmente eficaz para limpiar suelos, sanitarios, grifería, bidones de residuos y superficies brillantes y perfectamente limpias. Normalmente se utiliza allí donde existan necesidades de limpieza radical, eliminando también los malos olores. Conforme a la circular del ministerio de sanidad italiano n.º 5433 del 22/02/2020. Para uso profesional.</p>	
<p><b>Attrezzatura:</b> Sana Salute Sprayer Pump, spugna, panno <b>Diluizione:</b> 50 ml di prodotto in 1l di acqua <b>Colore:</b> incolore</p>		<p><b>Equipment:</b> Sana Salute Sprayer Pump, sponge, cloth <b>Dilution:</b> 50 ml of product in 1l of water <b>Color:</b> colourless</p>		<p><b>Herramientas:</b> aparato pulverizador, nebulizador, esponja, paño <b>Dilución:</b> 50 ml de producto in 1l di agua <b>Color:</b> incoloro</p>	

tecniche	certificazioni	proprietà	tecnologie



## sana salute pro outdoor



scheda  
tecnica



data  
sheet



ficha  
técnica



detergente igienizzante per superfici esterne	esterno	sanitising detergent for outdoor surfaces	outdoor	detergente desinfettante para superficies exteriores	exterior
Detergente igienizzante, sgrassante e sanificante cloro attivo per superfici esterne. La sua formulazione risulta particolarmente efficace per l'igienizzazione di strade, marciapiedi, parcheggi, ponteggi viali e vialetti. Conforme alla circolare del ministero della salute n° 5433 del 22/02/2020. Per uso professionale.		Active chlorine-based sanitising, degreasing detergent for outdoor surfaces. Its formulation is particularly effective in sanitising roads, sidewalks, parking lots, scaffolding, footpaths and driveways. Complies with Italian Ministry of Health Circular No. 5433 dated 22/02/2020. For professional use.		Detergente desinfettante, desengrasante y saneador de cloro activo para superficies exteriores. Su formulación resulta particularmente eficaz para la desinfección de calles, aceras, aparcamientos, andamios, avenidas y callejones. Conforme a la circular del ministerio de sanidad italiano n.° 5433 del 22/02/2020. Para uso profesional.	
<b>Attrezzatura:</b> Sana Salute Sprayer Pump <b>Diluizione:</b> 2 l di prodotto in 100 l di acqua <b>Colore:</b> incolore		<b>Equipment:</b> Sana Salute Sprayer Pump <b>Dilution:</b> 2 l of product in 100 l of water <b>Color:</b> colourless		<b>Herramientas:</b> Sana Salute Sprayer Pump <b>Dilución:</b> 2 l de producto en 100 l di agua <b>Color:</b> incoloro	

tecniche			certificazioni			proprietà			tecnologie		



scheda  
tecnica



data  
sheet



ficha  
técnica

## sana salute oxy



igienizzante per utensili a contatto con alimenti	interno esterno	sanitiser for utensils in contact with foodstuffs	indoor outdoor	desinfettante para utensilios en contacto con alimentos	interior exterior
Igienizzante per utensili a contatto con alimenti a base di perossido d'idrogeno stabilizzato e sali quaternari d'ammonio ad ampio spettro d'azione. Conforme alla normativa H.A.C.C.P. per l'utilizzo su attrezzature e superfici a contatto con alimenti. Esplica una notevole azione deodorante, conforme alla circ. 5443 del 22/02/2020 del Ministero della salute su prodotti idonei ad eliminare il nuovo Coronavirus (SARS-CoV-2). Per uso professionale.		Broad spectrum sanitiser for utensils in contact with foodstuffs based on stabilised hydrogen peroxide and quaternary ammonium salts. Complies with H.A.C.C.P. regulations on equipment and surfaces in contact with foodstuffs. It has a remarkable deodorising action, in accordance with Ministry of Health circular 5443 of 22/02/2020 concerning products able to eliminate the new Coronavirus (SARS-CoV-2). For professional use.		Desinfettante para utensilios en contacto con alimentos a base de peróxido de hidrógeno estabilizado y sales cuaternarias de amonio de amplio espectro de acción. Conforme a la normativa H.A.C.C.P. para el uso sobre herramientas y superficies en contacto con alimentos. Ejerce una notable acción desodorante, conforme a la circular 5443 del 22/02/2020 del Ministerio de sanidad italiano sobre los productos idóneos para eliminar el nuevo Coronavirus (SARS-CoV-2). Para uso profesional.	
<b>Attrezzatura:</b> Sana Salute Sprayer Pump, spugna, panno <b>Diluizione:</b> pronto all'uso o diluito al 60% con acqua <b>Colore:</b> incolore		<b>Equipment:</b> Sana Salute Sprayer Pump, sponge, cloth <b>Dilution:</b> ready to use or diluted at 60% with water <b>Color:</b> colourless		<b>Herramientas:</b> aparato pulverizador, nebulizador, esponja, paño <b>Dilución:</b> listo para usar o dilución al 60% con agua <b>Color:</b> incoloro	

tecniche				certificazioni			proprietà			tecnologie		

## sana salute sprayer pump



Nebulizzatore a batteria elettrica al litio per detergenti igienizzanti Virus-stop Indoor e Outdoor.	Lithium electric battery nebulizer for Virus-stop Indoor and Outdoor sanitizers.	Nebulizador eléctrico de batería de litio para detergentes desinfectantes para interior y exteriores Virus-stop
<b>Capacità:</b> 8 litri	<b>Capacity:</b> 8 liters	<b>Capacità:</b> 8 litros

## colonna porta gel

Colonna espositore per Sana Salute Gel 500 ml

Display column for Sana Salute Gel 500 ml

Column expositora para Sana Salute Gel 500 ml



	prodotto	caratteristiche principali	destinazione d'uso
<b>BEST SELLERS</b>	<b>traspicolor active</b> pag. 16	idropittura traspirante antimuffa certificata	interno
	<b>enjoy 1 coat</b> pag. 17	idropittura lavabile a mano unica	interno
<b>IDROSMALTI</b>	<b>idromatt</b> pag. 20	Idrosmalto opaco murale	interno / esterno
	<b>idrosatin</b> pag. 20	Idrosmalto satinato murale	interno / esterno
	<b>idrogloss</b> pag. 21	Idrosmalto lucido murale	interno / esterno
<b>LAVABILI</b>	<b>clean matt</b> pag. 24	idropittura superlavabile smacchiabile agli ioni d'argento	interno
	<b>luxury</b> pag. 24	idropittura superlavabile opaca	interno / esterno
	<b>tech active</b> pag. 25	idropittura lavabile opaca mascherante antimuffa	interno
	<b>sol-tex</b> pag. 25	idropittura lavabile riempitiva	interno
<b>IDROPITTURE</b>	<b>silan tech</b> pag. 28	idropittura traspirante acrisilossanica antimuffa	interno
	<b>traspinterno</b> pag. 28	idropittura traspirante universale	interno
	<b>white cream</b> pag. 29	idropittura traspirante effetto vellutato	interno
	<b>mural verde</b> pag. 29	idropittura murale traspirante opaca	interno
<b>PITTURE</b>	<b>mural blu</b> pag. 32	idropittura murale traspirante coprente	interno
	<b>pittura per interni extra</b> pag. 32	idropittura murale traspirante tinte tenui	interno
	<b>biancocalce</b> pag. 33	pittura a base di grassello di calce	interno
	<b>bianco interno</b> pag. 33	idropittura murale coprente opaca	interno
	<b>idroflex matt</b> pag. 34	Idropittura a spessore plastico bucciato	interno
	<b>idroflex gloss</b> pag. 34	idropittura a spessore plastico lavabile	interno
	<b>idrofumo</b> pag. 35	pittura opaca antifumo	interno
<b>VITA SANA</b>	<b>vita bianca</b> pag. 38	idropittura traspirante ipoallergenica	interno
	<b>vita wash</b> pag. 38	idropittura lavabile ipoallergenica	interno
	<b>vita therm</b> pag. 39	idropittura traspirante anticondensa	interno
	<b>sana bianca</b> pag. 40	idropittura traspirante antimuffa	interno
	<b>sanasil-bio</b> pag. 41	idropittura traspirante a base silicati	interno

colori	traspirabilità	copertura	lavabilità	brillantezza	altre proprietà	tecnologie	certificazioni
bianco	V1	class 2	S3	matt	---	active	A+; muffe e batteri
YouColor®	V1	class 1	S3	matt	pronto uso	---	A+
YouColor®	V3	---	S1	matt	---	resistance 5	A+; HACCP
YouColor®	V3	---	S1	satin	---	resistance 5	A+; HACCP
YouColor®	V3	---	S1	gloss	---	resistance 5	A+; HACCP
YouColor®	V3	class 1	S1	matt	cleanable	clean	A+; HACCP
YouColor®	---	class 1	S1	matt	---	---	A+
YouColor®	---	class 2	S2	matt	---	active	A+
YouColor®	V2	class 2	S3	matt	---	---	A+
YouColor®	V1	class 2	S3	matt	---	siloxan 4	---
YouColor®	V1	class 3	---	matt	---	---	---
bianco	V1	class 1	---	matt	---	---	A+
YouColor®	V1	class 2	---	matt	---	---	---
bianco	V1	class 3	---	matt	---	---	---
colorato	V1	class 3	---	matt	base calce	---	---
bianco	V1	class 4	---	matt	---	---	---
bianco	V1	class 4	---	matt	---	---	---
colorato	---	---	S3	matt	pronto uso	resistance 4	---
colorato	---	---	S3	satin	pronto uso	resistance 4	---
bianco	---	class 4	S3	satin	---	---	---
bianco	V1	class 1	---	matt	---	---	A+; anallergico; abbatte aldeidi
YouColor®	V2	class 2	S3	matt	---	---	A+; anallergico; abbatte aldeidi
bianco	V1	class 2	---	matt	anticondensa	---	A+; anallergico; abbatte aldeidi
YouColor®	V1	class 2	---	matt	---	---	muffe e batteri
YouColor®	V1	class 3	---	matt	mineral	silicate 5	

**anti-muffa - anti-mold - antimoho**

risanamento restoration acabado	consolidamento / imprimitura consolidation/ priming consolidación / imprimación	finitura finish acabado
<b>sana solux</b> pag.41	<b>acrilica 100</b> (opzionale) pag.81	<b>traspicolor active</b> pag.16 oppure <b>tech activ</b> pag.25 oppure <b>sana bianca</b> pag.40

**anti-condensa - anti-condensation - anticondensación**

risanamento restoration acabado	consolidamento / imprimitura consolidation/ priming consolidación / imprimación	finitura finish acabado
<b>sana solux</b> pag.41	<b>primer therm</b> pag.39	<b>vita therm</b> pag.39

**termico, anti-condensa - thermal, anti-condensation - termico, anticondensación**

risanamento restoration acabado	consolidamento / imprimitura consolidation/ priming consolidación / imprimación	rasante skim coat rasante	rasante di finitura skim coat of finish rasante de acabado	finitura finish acabado
<b>sana solux</b> (opzionale) pag.41	<b>primer therm</b> pag.39	<b>sana rasotherm</b> pag.40	<b>sana finish</b> pag.40	<b>vita therm</b> pag.39 oppure <b>sana bianca</b> pag.40

**cartongesso - plasterboard - panel de yeso**

consolidamento / imprimitura consolidation/ priming consolidación / imprimación	rasante per giunti skim coat for joint rasante de juntas	fondo undercoat fondos	finitura finish acabado
<b>acrilica 100</b> (opzionale) pag.81	<b>elastucco</b> (opzionale) pag.84	<b>prime tech</b> pag.76	<b>enjoy 1 coat</b> pag.17 oppure <b>traspicolor active</b> pag.16 oppure <b>tech active</b> pag.25 oppure prodotti delle linee lavabili o idrosmalti

### uniformante - unifying - uniformando

consolidamento / imprimitura consolidation/ priming consolidación / imprimación	strato uniformante uniforming layer capa uniformadora	finitura finish acabado
<b>acrilica 100</b> pag.81	<b>rasofondo color</b> pag.76 oppure <b>rasofondo flex</b> pag.77	<b>luxury</b> pag.24 oppure <b>silan tech</b> pag.28 oppure <b>sol-tex</b> pag.25

### contatto con alimenti (HACCP) - food contact - contacto con alimentos

consolidamento / imprimitura consolidation/ priming consolidación / imprimación	finitura finish acabado
<b>primacril</b> pag.80	<b>idrogloss</b> pag.21 oppure <b>idromatt</b> pag.20 oppure <b>idrosatin</b> pag.20

### smacchiabile - stain-removal - quitamanchas

consolidamento / imprimitura consolidation/ priming consolidación / imprimación	finitura (opzione 1) finish (option 1) acabado (opción 1)	finitura (opzione 2) finish (option 2) acabado (opción 2)
<b>acrilica 100</b> pag.81 oppure <b>primacril</b> pag.80	<b>clean matt</b> pag.24	<b>idrogloss</b> pag.21 oppure <b>idromatt</b> pag.20 oppure <b>idrosatin</b> pag.20

### minerale - mineral - mineral

consolidamento / imprimitura consolidation/ priming consolidación / imprimación	strato uniformante uniforming layer capa uniformadora	finitura finish acabado
<b>ivasil primer s</b> pag.81	<b>ivasil fondo</b> (opzionale) pag.77	<b>biancocalce</b> pag.33 oppure <b>old time paint</b> (Metropolis)

# paints

**pitture high tech per esterno**

# prodotti

silox plus

superquarz plus

ultra dry

superclean plus

superquarz plus strong

superquarz plus reflect

ivasgum side finish

quarzogum plus

idrobeton

ivasil pittura

deco sand plus

ivaglass

betonglass



# ht



## silox plus

scheda  
tecnicadata  
sheetficha  
técnica

idroittura polisilossanica a effetto vellutato	esterno	water-based polysiloxane paint with velvety effect	outdoor	pintura al agua polisiloxánica de efecto aterciopelado	exterior
Idropittura a base di resine polisilossaniche e cariche bilanciate, assicura elevata traspirabilità e bassissimo assorbimento d'acqua. La caratteristica formulazione conferisce semplicità di applicazione. Forma un film resistente all'attacco di alghe, funghi e muffe, grazie ad un'innovativa formulazione che prevede additivi a largo spettro certificata dall'Istituto GFC Chimica. La Classe TVOC A+ lo rende idoneo per ottemperare ai protocolli CAM, Leed Breeam. Per uso professionale.		Water-based paint containing polysiloxane resins and balanced fillers, ensuring high breathability and very low water absorption. The characteristic formulation makes it easy to apply. Produces a mould-, algae-, and fungi-resistant film using an innovative formulation based on broad spectrum additives certified by GFC Chimica institute. Classified TVOC A+, it complies with Leed Breeam protocols. For professional use.		Pintura al agua a base de resinas polisiloxánicas y cargas equilibradas, asegura una elevada transpirabilidad y una absorción de agua muy baja. Su formulación característica la hace de fácil aplicación. Forma una película resistente al ataque de algas, hongos y mohos, gracias a una innovadora formulación que incluye aditivos de amplio espectro certificada por el Instituto GFC Chimica. La Clase TVOC A+ la hace idónea para cumplir con los protocolos Leed Breeam. Para uso profesional.	
<b>Attrezzatura:</b> pennello, rullo, airless <b>Diluizione:</b> acqua - 1°mano: 20-30% - 2°mano: 15-20% <b>Resa</b> (2 mani): 3-4 m <sup>2</sup> /l - Per confezione (14 l): 56 m <sup>2</sup> <b>Colore:</b> bianco e colorato		<b>Equipment:</b> brush, roller, airless <b>Dilution:</b> water - 1°coat: 20-30% - 2°coat: 15-20% <b>Coverage</b> (2 coats): 3-4 m <sup>2</sup> /l - Per packaging (14 l): 56 m <sup>2</sup> <b>Color:</b> white and colored		<b>Herramientas:</b> brocha, rodillo, pistola pulverizadora <b>Dilución:</b> agua - 1°capa: 20-30% - 2°capa: 15-20% <b>Rendimiento</b> (2 capas): 3-4 m <sup>2</sup> /l - Por envase (14 l): 56 m <sup>2</sup> <b>Color:</b> blanco y colorido	

tecniche	certificazioni	proprietà	tecnologie

## superquarz plus

scheda  
tecnicadata  
sheetficha  
técnica

idroittura acrilisilossanica	esterno	water-based acrylic- siloxane paint	outdoor	pintura al agua acrilisiloxánica	exterior
Idropittura acrilisilossanica idrorepellente, traspirante, ad elevata resistenza agli agenti atmosferici ed allo sfarinamento, resiste all'alcalinità del supporto. Forma un film resistente all'attacco di alghe, funghi e muffe, grazie all'innovativa formulazione con additivi a largo spettro certificata dal Fraunhofer-Institut für Bauphysik di Monaco. La Classe TVOC A+ lo rende idoneo per ottemperare ai protocolli CAM, Leed Breeam. Per uso professionale.		Acrylsilossanic water-based paint breathable, high resistance to weathering and crumbling, resists the alkalinity of the support. It forms a film resistant to algae, fungi and moulds, thanks to the innovative formulation with wide-ranging additives certified by the Fraunhofer-Institut für Bauphysik of Munich. Classified TVOC A+, it complies with Leed Breeam protocols. For professional use.		Hidropintura acrilisiloxánica repelente al agua, transpirable, de elevada resistencia a los agentes atmosféricos y al deshielo, resiste a la alcalinidad del soporte. Forma una película resistente al ataque de algas, hongos y mohos, gracias a la innovadora formulación con aditivos de amplio espectro certificada por el Fraunhofer-Institut für Bauphysik de Munich. La Clase TVOC A+ la hace idónea para cumplir con los protocolos Leed Breeam. Para uso profesional.	
<b>Attrezzatura:</b> pennello, rullo, airless <b>Diluizione:</b> acqua - prima mano: 20-30%, seconda mano: 15-20% <b>Resa</b> (2 mani): 3-4 m <sup>2</sup> /l - Per confezione (14 l): 56 m <sup>2</sup> <b>Colore:</b> bianco e colorato		<b>Equipment:</b> brush, roller, airless <b>Dilution:</b> water - 1°coat: 20-30%, 2°coat: 15-20% <b>Coverage</b> (2 coats): 3-4 m <sup>2</sup> /l - Per packaging (14 l): 56 m <sup>2</sup> <b>Color:</b> white and colored		<b>Herramientas:</b> brocha, rodillo, pistola pulverizadora <b>Dilución:</b> agua - 1° capa: 20-30%, 2° capa: 15-20% <b>Rendimiento</b> (2 capas): 3-4 m <sup>2</sup> /l - Por envase (14 l): 56 m <sup>2</sup> <b>Color:</b> blanco y colorido	

tecniche	certificazioni	proprietà	tecnologie

## ultra dry



scheda  
tecnica



data  
sheet



ficha  
técnica



pittura idrorepellente protettiva	<b>esterno</b>	protective water repellent paint	<b>outdoor</b>	pintura hidro- repelente protectora	<b>exterior</b>
<p>Pittura liscia con tecnologia Dry che crea una barriera impenetrabile all'acqua, che non viene assorbita ma scorre sulla superficie, prevenendo in questa maniera l'accumulo di sporco e riducendo al minimo il deterioramento del film del prodotto. Questa particolare formulazione conferisce elevata resistenza agli agenti atmosferici e agli inquinanti trasportati dall'acqua. Per esterno. Per uso professionale.</p>		<p>Smooth paint which uses a Dry technology to create a barrier that water cannot penetrate, thus water is not absorbed but flows over the surface. This prevents the accumulation of dirt and minimises deterioration of the film. This particular formulation imparts high resistance to the weather and water-borne pollutants. For professional use.</p>		<p>Pintura lisa con tecnología Dry que crea una barrera impenetrable al agua, que no es absorbida, sino que resbala por la superficie, previniendo de ese modo la formación de suciedad y reduciendo al mínimo el deterioro de la película de producto. Esta particular formulación le proporciona una gran resistencia a los agentes atmosféricos y a los contaminantes transportados por el agua. Para uso profesional.</p>	
<p><b>Attrezzatura:</b> pennello, rullo, airless <b>Diluizione:</b> acqua - max 10% <b>Resa</b> (2 mani): 4-4,5 m<sup>2</sup>/l - Per confezione (14 l): 63 m<sup>2</sup> <b>Colore:</b> bianco e colorato</p>		<p><b>Equipment:</b> brush, roller, airless <b>Dilution:</b> water - max 10% <b>Coverage</b> (2 coats): 4-4,5 m<sup>2</sup>/l - Per packaging (14 l): 63 m<sup>2</sup> <b>Color:</b> white and colored</p>		<p><b>Herramientas:</b> brocha, rodillo, pistola pulverizadora <b>Dilución:</b> agua - max 10% <b>Rendimiento</b> (2 capas): 4-4,5 m<sup>2</sup>/l - Por envase (14 l): 63 m<sup>2</sup> <b>Color:</b> blanco y colorido</p>	

<b>tecniche</b>	<b>certificazioni</b>	<b>proprietà</b>	<b>tecnologie</b>

## superclean plus



scheda  
tecnica



data  
sheet



ficha  
técnica



idropittura autopulente ad effetto fotocatalitico	<b>esterno</b>	self-cleaning water- based paint with photocatalytic effect	<b>outdoor</b>	pittura al acqua autolimpiaadora de efecto fotocatalitico	<b>exterior</b>
<p>Idropittura a base di resine polisilossaniche, formulata con tecnologia nanometrica Clean atta a generare un effetto fotocatalitico ossidante in grado di decomporre le sostanze organiche che vengono a contatto con la superficie conferendo al film funzione autopulente. Aspetto opaco vellutato, insensibile all'alcalinità del supporto; idrorepellente. Per uso professionale</p>		<p>Water-based paint containing polysiloxane resins, formulated using nanometre Clean technology in which oxidizing photocatalysis breaks down the organic substances in contact with the surface, giving the film self-cleaning properties. Velvety matt appearance, insensitive to the alkalinity of the substrate; water-repellent. For professional use.</p>		<p>Pintura al agua a base de resinas polisiloxánicas, formulada con tecnología nanométrica Clean que genera un efecto fotocatalitico oxidante capaz de descomponer las sustancias orgánicas que entran en contacto con la superficie y proporciona a la película una función autolimpiadora. Aspecto mate aterciopelado, insensibile a la alcalinidad del soporte; hidro-repelente. Para uso profesional.</p>	
<p><b>Attrezzatura:</b> pennello, rullo, airless <b>Diluizione:</b> acqua - 1°mano: 20-30%; 2°mano: 15-20% <b>Resa</b> (2 mani): 3-4 m<sup>2</sup>/l - Per confezione (14 l): 56 m<sup>2</sup> <b>Colore:</b> bianco e colorato</p>		<p><b>Equipment:</b> brush, roller, airless <b>Dilution:</b> water - 1°coat: 20-30%; 2°coat: 15-20% <b>Coverage</b> (2 coats): 3-4 m<sup>2</sup>/l - Per packaging (14 l): 56 m<sup>2</sup> <b>Color:</b> white and colored</p>		<p><b>Herramientas:</b> brocha, rodillo, pistola pulverizadora <b>Dilución:</b> agua - 1°capa: 20-30%; 2°capa: 15-20% <b>Rendimiento</b> (2 capas): 3-4 m<sup>2</sup>/l - Por envase (14 l): 56 m<sup>2</sup> <b>Color:</b> blanco y colorido</p>	

<b>tecniche</b>	<b>certificazioni</b>	<b>proprietà</b>	<b>tecnologie</b>

## superquarz plus strong

scheda  
tecnicadata  
sheetficha  
técnica

idropittura per colori intensi	esterno	water-based paint for intense colours	outdoor	pintura al agua para colores intensos	exterior
Idropittura a base di resine in dispersione acquosa e pigmenti basati su tecnologia Strong che conferiscono al film elevata resistenza alla luce e possibilità di ottenere una vasta gamma di colori intensi e dal tono estremamente vivo. Di aspetto opaco, a basso assorbimento d'acqua, possiede elevata resistenza agli agenti atmosferici e allo sfarinamento. Resistente all'attacco di alghe, funghi e muffe. Per uso professionale		Water-based with balanced particle size fillers containing resins dispersed in water and pigments based on Strong technology. Makes it possible to obtain a wide range of intense colours with very vibrant tones. Matt finish and low water absorption. High resistance to the weather and chalking. Resistant to algae, fungi, mould and mildew. For professional use.		Pintura al agua a base de resinas en dispersión acuosa y pigmentos basados en la tecnología Strong que proporciona a la película una gran resistencia a la luz y la posibilidad de obtener una amplia gama de colores intensos y de tono extremadamente vivo. De aspecto mate, de baja absorción de agua, posee una gran resistencia a los agentes atmosféricos y a la desintegración pulverulenta. Resistente al ataque de algas, hongos y mohos. Para uso profesional.	
<b>Attrezzatura:</b> pennello, rullo, airless <b>Diluizione:</b> acqua - 15-20% <b>Resa</b> (2 mani): 3-4 m <sup>2</sup> /l - Per confezione (14 l): 56 m <sup>2</sup> <b>Colore:</b> bianco e colorato		<b>Equipment:</b> brush, roller, airless <b>Dilution:</b> water - 15-20% <b>Coverage</b> (2 coats): 3-4 m <sup>2</sup> /l - Per packaging (14 l): 56 m <sup>2</sup> <b>Color:</b> white and colored		<b>Herramientas:</b> brocha, rodillo, pistola pulverizadora <b>Dilución:</b> agua - 15-20% <b>Rendimiento</b> (2 capas): 3-4 m <sup>2</sup> /l - Por envase (14 l): 56 m <sup>2</sup> <b>Color:</b> blanco y colorido	

tecniche	certificazioni	proprietà	tecnologie
 COLOURABLE  WATER BASED  BRUSH  ROLLER  AIRLESS		 BREATHABLE	 plus  strong

## superquarz plus reflect

scheda  
tecnicadata  
sheetficha  
técnica

idropittura riflettente	esterno	reflective water-based paint	outdoor	pintura al agua reflectante	exterior
Idropittura a base di resine in dispersione acquosa e "cool pigment" basati su tecnologia Reflect (Total Solar Reflectance) che permettono di realizzare colori dalle tonalità scure, limitando il riscaldamento eccessivo del film superficiale. Finitura opaca vellutata, insensibile all'alcalinità del supporto; idrorepellente e traspirante. Resistente all'attacco di alghe, funghi e muffe. Per uso professionale		Acryl water-based paint with balanced particle size fillers dispersed in water and "cool pigments" based on Reflect technology (Total Solar Reflectance). It can be used to create colours with dark tones, keeping excessive heating of the surface film to a minimum. Velvety matt finish, insensitive to the alkalinity of the substrate; water-repellent. Resistant to algae, fungi, mould and mildew. For professional use.		Pintura al agua a base de resinas en dispersión acuosa y "cool pigment" basados en la tecnología Reflect (Total Solar Reflectance) que permiten realizar colores de tonalidades oscuras limitando al mismo tiempo el calentamiento excesivo de la película superficial. Acabado mate aterciopelado, insensible a la alcalinidad del soporte; hidro-repellente y transpirante. Resistente al ataque de algas, hongos y mohos. Para uso profesional.	
<b>Attrezzatura:</b> pennello, rullo, airless <b>Diluizione:</b> acqua - prima mano: 20-30%, seconda mano: 15-20% <b>Resa</b> (2 mani): 3-4 m <sup>2</sup> /l - Per confezione (14 l): 56 m <sup>2</sup> <b>Colore:</b> bianco e colorato		<b>Equipment:</b> brush, roller, airless <b>Dilution:</b> water - 1° coat: 20-30%, 2° coat: 15-20% <b>Coverage</b> (2 coats): 3-4 m <sup>2</sup> /l - Per packaging (14 l): 56 m <sup>2</sup> <b>Color:</b> white and colored		<b>Herramientas:</b> brocha, rodillo, pistola pulverizadora <b>Dilución:</b> agua - 1° capa: 20-30%, 2° capa: 15-20% <b>Rendimiento</b> (2 capas): 3-4 m <sup>2</sup> /l - Por envase (14 l): 56 m <sup>2</sup> <b>Color:</b> blanco y colorido	

tecniche	certificazioni	proprietà	tecnologie
 WATER BASED  BRUSH  ROLLER  AIRLESS		 BREATHABLE	 plus  reflect

## ivasgum side finitura



scheda  
tecnica



data  
sheet



ficha  
técnica



elastomerica	esterno	elastomeric paint	outdoor	pintura elastomérica	exterior
<p>Pittura elastomerica extrafine a base di cariche inerti disperse in resine elastiche che conferiscono elevata elasticità e impermeabilità all'acqua, anche a bassi spessori. Idonea come finitura per ciclo elastomerico Ivas per superfici microfessurate. Forma una barriera alla penetrazione della CO<sub>2</sub> sul cemento armato a vista. Per uso professionale.</p>		<p>Extra-fine elastomeric paint containing inert fillers dispersed in elastic resins that provide high elasticity and water resistance, even in thin coats. Suitable as topcoat for Ivas elastomeric process for surfaces with micro-cracks. Forms a barrier against the penetration of CO<sub>2</sub> into exposed reinforced concrete. For professional use.</p>		<p>Pintura elastomérica extrafina a base de cargas inertes dispersas en resinas elásticas que proporcionan una gran elasticidad e impermeabilidad al agua, incluso con espesores bajos. Idónea como acabado para ciclo elastomérico Ivas para superficies microfisuradas. Forma una barrera contra la penetración del CO<sub>2</sub> en el cemento armado a la vista. Para uso profesional.</p>	
<p><b>Attrezzatura:</b> pennello, rullo a pelo corto, airless <b>Diluizione:</b> acqua - 10-15% <b>Resa</b> (2 mani): 4-5 m<sup>2</sup>/l - Per confezione (14 l): 70 m<sup>2</sup> <b>Colore:</b> bianco e colorato</p>		<p><b>Equipment:</b> brush, roller, airless <b>Dilution:</b> water - 10-15% <b>Coverage</b> (2 coats): 4-5 m<sup>2</sup>/l - Per packaging (14 l): 70 m<sup>2</sup> <b>Color:</b> white and colored</p>		<p><b>Herramientas:</b> brocha, rodillo a pelo corto, pistola pulverizadora <b>Dilución:</b> agua - 10-15% <b>Rendimiento</b> (2 capas): 4-5 m<sup>2</sup>/l - Por envase (14 l): 70 m<sup>2</sup> <b>Color:</b> blanco y colorido</p>	

tecniche	certificazioni	proprietà	tecnologie

## quarzogum plus



scheda  
tecnica



data  
sheet



ficha  
técnica



pittura elastomerica riempitiva al quarzo	esterno	elastomeric paint with quartz fillers	outdoor	pintura elastomérica de relleno con cuarzo	exterior
<p>Pittura riempitiva al quarzo alcaliresistente a base di resine elastomeriche, inerti, e sabbie in dispersione acquosa. La caratteristica elastica la rende idonea come finitura per cicli elastomerici anticavillature e la rende impermeabile ed altamente resistente alla presa di sporco. A film protetto dall'attacco di alghe, muffe e microorganismi. Per uso professionale.</p>		<p>Paint with quartz filler based on elastomeric resins, inert material and sands dispersed in water. Its elastic properties make it suitable as crack-preventing topcoat for elastomeric processes and renders it both waterproof and highly resistant to dirt retention. The product film protects against algae, mould and microorganisms. For professional use.</p>		<p>Pintura de relleno con cuarzo, resistente a los álcalis, a base de resinas elastoméricas, áridos y arenas en dispersión acuosa. Su característica elástica la hace idónea como acabado para ciclos elastoméricos anticuarteados, la hace impermeable y le proporciona una gran resistencia a la retención de suciedad. Forma una película protectora contra el ataque de algas, mohos y microorganismos. Para uso profesional.</p>	
<p><b>Attrezzatura:</b> pennello, rullo a pelo corto, airless <b>Diluizione:</b> acqua - 15-20% <b>Resa</b> (2 mani): 4-5 m<sup>2</sup>/l - Per confezione (14 l): 70 m<sup>2</sup> <b>Colore:</b> bianco e colorato</p>		<p><b>Equipment:</b> brush, roller, airless <b>Dilution:</b> water - 15-20% <b>Coverage</b> (2 coats): 4-5 m<sup>2</sup>/l - Per packaging (14 l): 70 m<sup>2</sup> <b>Color:</b> white and colored</p>		<p><b>Herramientas:</b> brocha, rodillo a pelo corto, pistola pulverizadora <b>Dilución:</b> agua - 15-20% <b>Rendimiento</b> (2 capas): 4-5 m<sup>2</sup>/l - Por envase (14 l): 70 m<sup>2</sup> <b>Color:</b> blanco y colorido</p>	

tecniche	certificazioni	proprietà	tecnologie

## idrobeton

scheda  
tecnicadata  
sheetficha  
técnica

pittura anticarbonatazione	interno esterno	anti-carbonation paint	indoor outdoor	pintura anticarbonatación	interior exterior
Pittura acrilica anticarbonatante particolarmente idonea per il trattamento del calcestruzzo a vista. Possiede un elevato potere penetrante ed elevato effetto barriera alla penetrazione dei gas, CO <sub>2</sub> e SO <sub>2</sub> . Permeabilità all'anidride carbonica (EN 1062): Sd 200,29m; Classe C1. La Classe TVOC A+ lo rende idoneo per ottemperare ai protocolli CAM, Leed Breeam. Per uso professionale		Acrylic anti-carbonation paint, particularly suited to the treatment of exposed concrete. It offers high penetrating power and high barrier effect against the penetration of gases, CO <sub>2</sub> and SO <sub>2</sub> . Permeability to carbon dioxide (EN 1062): Sd 200,29m; Class C1. Classified TVOC A+, it complies with Leed Breeam protocols. For professional use.		Pintura acrílica anticarbonatante particularmente adecuada para el tratamiento del hormigón a la vista. Posee un elevado poder penetrante y elevado efecto barrera contra la penetración de gases, CO <sub>2</sub> y SO <sub>2</sub> . Permeabilidad al anhídrido carbónico (EN 1062): Sd 200,29 m; Clase C1. La Clase TVOC A+ la hace idónea para cumplir con los protocolos Leed Breeam. Para uso profesional.	
<b>Attrezzatura:</b> pennello, rullo, airless <b>Diluizione:</b> acqua - 20-30% <b>Resa</b> (2 mani): 5 m <sup>2</sup> /l - Per confezione (14 l): 70 m <sup>2</sup> <b>Colore:</b> bianco e colorato		<b>Equipment:</b> brush, roller, airless <b>Dilution:</b> water - 20-30% <b>Coverage</b> (2 coats): 5 m <sup>2</sup> /l - Per packaging (14 l): 70 m <sup>2</sup> <b>Color:</b> white and colored		<b>Herramientas:</b> brocha, rodillo, pistola pulverizadora <b>Dilución:</b> agua - 20-30% <b>Rendimiento</b> (2 capas): 5 m <sup>2</sup> /l - Por envase (14 l): 70 m <sup>2</sup> <b>Color:</b> blanco y colorido	

tecniche	certificazioni	proprietà	tecnologie

## ivasil pittura

scheda  
tecnicadata  
sheetficha  
técnica

idropittura minerale ai silicati	interno esterno	water-based mineral paint with silicates	indoor outdoor	pintura mineral al agua mineral con silicatos	interior exterior
Idropittura minerale ai silicati che assicura traspirabilità al vapore, idrorepellenza, resistenza agli agenti atmosferici e ai raggi UV. La componente minerale al silicato di potassio svolge una naturale protezione contro muffe e alghe. Resistente agli alcali. Particolarmente idonea per la pitturazione di edifici di interesse storico. Conforme alla norma DIN 18363. Per uso professionale.		Water-based mineral paint with silicates that is vapour permeable, water repellent, resistant to the weather and UV light. The mineral component based on potassium silicate provides natural protection against mould, mildew and algae. Resistant to alkalis. Ideal for painting buildings in historic centres. For professional use.		Pintura mineral al agua con silicatos que asegura transpirabilidad al vapor, hidro-repelente, resistente a los agentes atmosféricos y a los rayos UV. El componente mineral con silicato de potasio ejerce una protección natural contra mohos y algas. Resistente a los álcalis. Particularmente idónea para el pintado de edificios en cascos antiguos. Para uso profesional.	
<b>Attrezzatura:</b> pennello, rullo a pelo corto, spruzzo <b>Diluizione:</b> Ivasil Primer S - 15-20% <b>Resa</b> (2 mani): 4,5-5,5 m <sup>2</sup> /l - Per confezione (14 l): 77 m <sup>2</sup> <b>Colore:</b> bianco e colorato		<b>Equipment:</b> brush, roller, airless <b>Dilution:</b> Ivasil Primer S - 15-20% <b>Coverage</b> (2 coats): 4,5-5,5 m <sup>2</sup> /l - Per packaging (14 l): 77 m <sup>2</sup> <b>Color:</b> white and colored		<b>Herramientas:</b> brocha, rodillo a pelo corto, pistola pulverizadora <b>Dilución:</b> Ivasil Primer S - 15-20% <b>Rendimiento</b> (2 capas): 4,5-5,5 m <sup>2</sup> /l - Por envase (14 l): 77 m <sup>2</sup> <b>Color:</b> blanco y colorido	

tecniche	certificazioni	proprietà	tecnologie

## deco sand plus



scheda  
tecnica



data  
sheet



ficha  
técnica



<p>idropittura mascherante ad effetto decorativo sabbato</p>	<p><b>interno esterno</b></p>	<p>water-based masking paint with decorative sandblasted</p>	<p><b>indoor outdoor</b></p>	<p>pintura al agua enmascarante de efecto decorativo arenado</p>	<p><b>interior exterior</b></p>
<p>Idropittura acrilossilossanica con farina di quarzo ad alto potere mascherante e riempitivo. La curva granulometrica rende la finitura idonea per uniformare e mascherare facciate rappazzate ottenendo un'elevata copertura e resistenza agli agenti atmosferici. L'applicazione della seconda mano con idonea pennellessa permette di ottenere una finitura ad effetto sabbato ad alto valore estetico. Film protetto dall'attacco di alghe, muffe e microrganismi. Per uso professionale.</p>		<p>Water-based acrylic-siloxane paint containing quartz flour with high masking and filling properties. The range in size of the particles makes it possible to smooth out and mask patched façades, obtaining high coverage and resistance to the weather. By applying the second coat with a suitable flat brush, a highly attractive, sandblasted effect can be achieved. Film protected against algae, mould and microorganisms. For professional use.</p>		<p>Pintura al agua acrilossiloxánica con harina de cuarzo de gran poder enmascarante y de relleno. La curva granulométrica hace de ella el acabado idóneo para uniformar y enmascarar fachadas con reparaciones para obtener una gran capacidad cubriente y resistencia a los agentes atmosféricos. La aplicación de la segunda mano con una brocha ancha permite obtener un acabado de efecto arena de alto valor estético. Película protectora contra el ataque de algas, mohos y microorganismos. Para uso profesional.</p>	
<p><b>Attrezzatura:</b> pennello, rullo <b>Diluizione:</b> acqua - 0-15% <b>Resa</b> (1 mano): 3,5-5,5 m<sup>2</sup>/l - Per confezione (14 l): 49-77 m<sup>2</sup> <b>Colore:</b> bianco e colorato</p>		<p><b>Equipment:</b> brush, roller <b>Dilution:</b> water - 0-15% <b>Coverage</b> (1 coat): 3,5-5,5 m<sup>2</sup>/l - Per packaging (14 l): 49-77 m<sup>2</sup> <b>Color:</b> white and colored</p>		<p><b>Herramientas:</b> brocha, rodillo <b>Dilución:</b> agua - 0-15% <b>Rendimiento</b> (1 capa): 3,5-5,5 m<sup>2</sup>/l - Por envase (14 l): 49-77 m<sup>2</sup> <b>Color:</b> blanco y colorido</p>	

tecniche				certificazioni				proprietà				tecnologie				



## ivaglass lucido

scheda  
tecnicadata  
sheetficha  
técnica

smalto bicomponente acrilpoliuretano	interno esterno	two-pack acryl-polyurethane enamel	indoor outdoor	esmalte bicomponente acrilpoliuretánico	interior exterior
Smalto bicomponente acrilpoliuretano lucido non ingiallente, a base di pigmenti di alto pregio dispersi in veicolo acrilico, induritore isocianato alifatico. Dotato di elevata resistenza agli agenti chimici, alle soluzioni saline e all'esposizione in atmosfera industriale aggressiva e marina e particolarmente idoneo su supporti a bassa adesione. La particolare formulazione permette di realizzare tinte RAL anche per applicazione su grandi superfici di capannoni industriali. Per uso professionale.		Gloss two-pack, non-yellowing, acryl-polyurethane enamel based on high quality pigments dispersed in an acrylic medium and aliphatic isocyanate hardener. Highly resistant to chemicals, saline solutions and to exposure in aggressive industrial and marine atmospheres. Particularly suitable for substrates offering poor adhesion. Its unique formulation makes it possible to create RAL colours, even for application on the large surfaces of industrial warehouses. For professional use.		Esmalte bicomponente acrilpoliuretánico brillante no amarilla, a base de pigmentos de alta calidad dispersos en vehículo acrílico, endurecedor isocianato alifático. Dotado de alta resistencia a los agentes químicos, a las soluciones salinas y a la exposición a atmósfera industrial agresiva y marina; particularmente idóneo sobre soportes poco adhesivos. Su particular formulación permite realizar tintes RAL también para su aplicación sobre grandes superficies de naves industriales. Para uso profesional.	
<b>Attrezzatura:</b> pennello, rullo, airless <b>Rapporto di catalisi:</b> (A:B) 3:1 in volume <b>Diluizione:</b> Diluente per Poliuretano - max 10% (ailess max 15%) <b>Resa (2 mani):</b> 4-4,5 m <sup>2</sup> /l - Per confezione (12 l + 4 l): 72 m <sup>2</sup> <b>Colore:</b> bianco e colorato		<b>Equipment:</b> brush, roller, airless <b>Ratio of catalysis:</b> (A:B) 3:1 in volume <b>Dilution:</b> Diluente per Poliuretano - max 10% (ailess max 15%) <b>Coverage (2 coats):</b> 4-4,5 m <sup>2</sup> /l - Per packaging (12 l + 4 l): 72 m <sup>2</sup> <b>Color:</b> white and colored		<b>Herramientas:</b> brocha, rodillo, pistola pulverizadora <b>Relación de mezcla:</b> (A:B) 3:1 por volumen <b>Dilución:</b> Diluente per Poliuretano - 10% (pistola pulverizadora max 15%) <b>Rendimiento (2 capas):</b> 4-4,5 m <sup>2</sup> /l - Por envase (12 l + 4 l): 72 m <sup>2</sup> <b>Color:</b> blanco y colorido	

tecniche	certificazioni	proprietà	tecnologie

## ivaglass opaco

scheda  
tecnicadata  
sheetficha  
técnica

smalto bicomponente acrilpoliuretano	interno esterno	two-pack acryl-polyurethane enamel	indoor outdoor	esmalte bicomponente acrilpoliuretánico	interior exterior
Smalto bicomponente acrilpoliuretano opaco, non ingiallente, a base di pigmenti di alto pregio dispersi in veicolo acrilico, induritore isocianato alifatico. Dotato di elevata resistenza agli agenti chimici, alle soluzioni saline e all'esposizione in atmosfera industriale aggressiva e marina e particolarmente idoneo su supporti a bassa adesione. La particolare formulazione permette di realizzare tinte RAL anche per applicazione su grandi superfici di capannoni industriali. Per uso professionale.		Matt two-pack, non-yellowing, acryl-polyurethane enamel based on high quality pigments dispersed in an acrylic medium and aliphatic isocyanate hardener. Highly resistant to chemicals, saline solutions and to exposure in aggressive industrial and marine atmospheres. Particularly suitable for substrates offering poor adhesion. Its unique formulation makes it possible to create RAL colours, even for application on the large surfaces of industrial warehouses. For professional use.		Esmalte bicomponente acrilpoliuretánico mate, no amarilla, a base de pigmentos de alta calidad dispersos en vehículo acrílico, endurecedor isocianato alifático. Dotado de alta resistencia a los agentes químicos, a las soluciones salinas y a la exposición a atmósfera industrial agresiva y marina; particularmente idóneo sobre soportes poco adhesivos. Su particular formulación permite realizar tintes RAL también para su aplicación sobre grandes superficies de naves industriales. Para uso profesional.	
<b>Attrezzatura:</b> pennello, rullo, airless <b>Rapporto di catalisi:</b> (A:B) 3:1 in volume <b>Diluizione:</b> Diluente per Poliuretano - max 10% (ailess max 15%) <b>Resa (2 mani):</b> 4-4,5 m <sup>2</sup> /l - Per confezione (12 l + 4 l): 72 m <sup>2</sup> <b>Colore:</b> bianco e colorato		<b>Equipment:</b> brush, roller, airless <b>Ratio of catalysis:</b> (A:B) 3:1 in volume <b>Dilution:</b> Diluente per Poliuretano - max 10% (ailess max 15%) <b>Coverage (2 coats):</b> 4-4,5 m <sup>2</sup> /l - Per packaging (12 l + 4 l): 72 m <sup>2</sup> <b>Color:</b> white and colored		<b>Herramientas:</b> brocha, rodillo, pistola pulverizadora <b>Relación de mezcla:</b> (A:B) 3:1 por volumen <b>Dilución:</b> Diluente per Poliuretano - 10% (pistola pulverizadora max 15%) <b>Rendimiento (2 capas):</b> 4-4,5 m <sup>2</sup> /l - Por envase (12 l + 4 l): 72 m <sup>2</sup> <b>Color:</b> blanco y colorido	

tecniche	certificazioni	proprietà	tecnologie



## betonglass lucido



scheda  
tecnica



data  
sheet



ficha  
técnica



<p>smalto lucido bicomponente acrilpoliuretano per CLS</p> <p><b>interno esterno</b></p>	<p>two-pack acryl-polyurethane enamel for concrete</p> <p><b>indoor outdoor</b></p>	<p>esmalte bicomponente acrilpoliuretánico para hormigón</p> <p><b>interior exterior</b></p>
<p>Smalto bicomponente acril-poliuretano lucido non ingiallente, specificatamente formulato per la protezione del calcestruzzo. Dotato di elevata resistenza agli agenti chimici, alle soluzioni saline ed all'esposizione in atmosfera industriale aggressiva e marina.</p>	<p>Gloss two-pack, non-yellowing, acryl-polyurethane enamel formulated specifically to protect concrete. Highly resistant to chemicals, saline solutions and to exposure in aggressive industrial and marine atmospheres. For professional use.</p>	<p>Esmalte bicomponente acrilpoliuretánico brillante, no amarillea, formulado específicamente para la protección del hormigón. Dotado de alta resistencia a los agentes químicos, a las soluciones salinas y a la exposición a atmósfera industrial agresiva y marina. Para uso profesional.</p>
<p><b>Attrezzatura:</b> pennello, rullo, airless <b>Rapporto di catalisi:</b> (A:B) 3:1 in volume <b>Diluizione:</b> Diluente per Poliuretani - max 10% (airless max 15%) <b>Resa (2 mani):</b> 4-4,5 m<sup>2</sup>/l - Per confezione (12 l + 4 l): 72 m<sup>2</sup> <b>Colore:</b> bianco e colorato</p>	<p><b>Equipment:</b> brush, roller, airless <b>Ratio of catalysis:</b> (A:B) 3:1 in volume <b>Dilution:</b> Diluente per Poliuretani - max 10% (airless max 15%) <b>Coverage (2 coats):</b> 4-4,5 m<sup>2</sup>/l - Per packaging (12 l + 4 l): 72 m<sup>2</sup> <b>Color:</b> white and colored</p>	<p><b>Herramientas:</b> brocha, rodillo, pistola pulverizadora <b>Relación de mezcla:</b> (A:B) 3:1 por volumen <b>Dilución:</b> Diluyente per Poliuretani - max 10% (pistola pulverizadora max 15%) <b>Rendimiento (2 capas):</b> 4-4,5 m<sup>2</sup>/l - Por envase (12 l + 4 l): 72 m<sup>2</sup> <b>Color:</b> blanco y colorido</p>

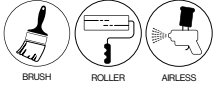

tecniche	certificazioni	proprietà	tecnologie
SOLVENT BASED BRUSH ROLLER AIRLESS		gloss BRILLIANCE WALKABLE	resistance 5

## betonglass opaco



scheda  
tecnica



data  
sheet



ficha  
técnica



<p>smalto opaco bicomponente acrilpoliuretano per CLS</p> <p><b>interno esterno</b></p>	<p>two-pack acryl-polyurethane enamel for concrete</p> <p><b>indoor outdoor</b></p>	<p>esmalte bicomponente acrilpoliuretánico para hormigón</p> <p><b>interior exterior</b></p>
<p>Smalto bicomponente acril-poliuretano opaco, non ingiallente, specificatamente formulato per la protezione del calcestruzzo. Dotato di elevata resistenza agli agenti chimici, alle soluzioni saline ed all'esposizione in atmosfera industriale aggressiva e marina. Per uso professionale.</p>	<p>Matt two-pack, non-yellowing, acryl-polyurethane enamel formulated specifically to protect concrete. Highly resistant to chemicals, saline solutions and to exposure in aggressive industrial and marine atmospheres. For professional use.</p>	<p>Esmalte bicomponente acrilpoliuretánico mate, no amarillea, formulado específicamente para la protección del hormigón. Dotado de alta resistencia a los agentes químicos, a las soluciones salinas y a la exposición a atmósfera industrial agresiva y marina. Para uso profesional.</p>
<p><b>Attrezzatura:</b> pennello, rullo, airless <b>Rapporto di catalisi:</b> (A:B) 3:1 in volume <b>Diluizione:</b> Diluente per Poliuretani - max 10% (airless max 15%) <b>Resa (2 mani):</b> 4-4,5 m<sup>2</sup>/l - Per confezione (12 l + 4 l): 72 m<sup>2</sup> <b>Colore:</b> bianco e colorato</p>	<p><b>Equipment:</b> brush, roller, airless <b>Ratio of catalysis:</b> (A:B) 3:1 in volume <b>Dilution:</b> Diluente per Poliuretani - max 10% (airless max 15%) <b>Coverage (2 coats):</b> 4-4,5 m<sup>2</sup>/l - Per packaging (12 l + 4 l): 72 m<sup>2</sup> <b>Color:</b> white and colored</p>	<p><b>Herramientas:</b> brocha, rodillo, pistola pulverizadora <b>Relación de mezcla:</b> (A:B) 3:1 por volumen <b>Dilución:</b> Diluyente per Poliuretani - max 10% (pistola pulverizadora max 15%) <b>Rendimiento (2 capas):</b> 4-4,5 m<sup>2</sup>/l - Por envase (12 l + 4 l): 72 m<sup>2</sup> <b>Color:</b> blanco y colorido</p>

tecniche	certificazioni	proprietà	tecnologie
SOLVENT BASED BRUSH ROLLER AIRLESS		matt BRILLIANCE WALKABLE	resistance 5



# exterio

**rivestimenti e finiture high tech**

# prodotti

intogum plus g12

intogum plus g10

intonachino idrosiliconico plus g08

intonachino idrosiliconico plus g06

rivasil g15

rivasil g12

ivasil intonachino g08



orht

## intogum plus g12

scheda  
tecnicadata  
sheetficha  
técnica

rivestimento a spessore elastomerico - 1.2 mm	esterno	thick elastomeric coating - 1.2 mm	outdoor	revestimiento de espesor elastomérico - 1.2 mm	exterior
Rivestimento all'acqua a spessore caratterizzato da un alto potere riempitivo. Possiede elevate resistenze meccaniche unite ad un alto valore dell'allungamento percentuale riducendo i rischi di cavillature e screpolature del prodotto sollecitato a forti tensioni superficiali. Si presta come barriera alla penetrazione della CO <sub>2</sub> sui cementi armati a vista. Forma un film resistente all'attacco di alghe, funghi e muffe. Per uso professionale.		Thick water-based coating with high filling power. Offers high mechanical resistance together with a high percentage elongation value, thus reducing the risk of cracks and fissures in the product when subject to strong surface tensions. Serves as a barrier to CO <sub>2</sub> penetration into exposed reinforced concrete. Produces a mould, algae, and fungi-resistant film. For professional use.		Revestimiento de espesor al agua caracterizado por un alto poder de relleno. Posee una gran resistencia mecánica que, junto con un alto valor de alargamiento porcentual, reduce los riesgos de cuarteados y agrietamientos del producto sometido a fuertes tensiones superficiales. Se presta como barrera a la penetración del CO <sub>2</sub> en hormigones armados a la vista. Forma una película resistente al ataque de algas, hongos y mohos. Para uso profesional.	
<b>Granulometria:</b> 1,2 mm <b>Attrezzatura:</b> spatola di acciaio <b>Diluizione:</b> pronto all'uso <b>Resa</b> (1 mano): 1,9 kg/ m <sup>2</sup> - Per confezione (25 kg): 13 m <sup>2</sup> <b>Colore:</b> bianco e colorato		<b>Particle size:</b> 1,2 mm <b>Equipment:</b> steel spatula <b>Dilution:</b> ready to use <b>Coverage</b> (1 coat): 1,9 kg/ m <sup>2</sup> - Per packaging (25 kg): 13 m <sup>2</sup> <b>Color:</b> white and colored		<b>Granulometría:</b> 1,2 mm <b>Herramientas:</b> espátula de acero <b>Dilución:</b> listo para usar <b>Rendimiento</b> (1 capa): 1,9 kg/ m <sup>2</sup> - Por envase (25 kg): 13 m <sup>2</sup> <b>Color:</b> blanco y colorido	

tecniche	certificazioni	proprietà	tecnologie
WATER BASED TROWEL READY TO USE	CE EN 15824	BREATHABLE	plus flex 5 cig protect 4

## intogum plus g10

scheda  
tecnicadata  
sheetficha  
técnica

rivestimento a spessore elastomerico - 1 mm	esterno	thick elastomeric coating - 1 mm	outdoor	revestimiento de espesor elastomérico 1 mm	exterior
Rivestimento all'acqua a spessore caratterizzato da un alto potere riempitivo. Applicato a due mani possiede elevate resistenze meccaniche unite ad un alto valore dell'allungamento percentuale riducendo i rischi di cavillature e screpolature del prodotto sollecitato a forti tensioni superficiali. Si presta come barriera alla penetrazione della CO <sub>2</sub> sui cementi armati a vista. Forma un film resistente all'attacco di alghe, funghi e muffe. Per uso professionale.		Thick water-based coating with high filling power. When applied in two coats, it offers high mechanical resistance together with a high percentage elongation value, thus reducing the risk of cracks and fissures in the product when subject to strong surface tensions. Serves as a barrier to CO <sub>2</sub> penetration into exposed reinforced concrete. Produces a mould-, algae-, and fungi-resistant film. For professional use.		Revestimiento de espesor al agua caracterizado por un alto poder de relleno. Aplicado en dos manos, posee una gran resistencia mecánica que, junto con un alto valor de alargamiento porcentual, reduce los riesgos de cuarteados y agrietamientos del producto sometido a fuertes tensiones superficiales. Se presta como barrera a la penetración del CO <sub>2</sub> en hormigones armados a la vista. Forma una película resistente al ataque de algas, hongos y mohos. Para uso profesional.	
<b>Granulometria:</b> 0,9 - 1mm <b>Attrezzatura:</b> spatola di acciaio <b>Diluizione:</b> pronto all'uso <b>Resa</b> (1 mano): 1,5-1,6 kg/m <sup>2</sup> - Per confezione (25 kg): 16,5 m <sup>2</sup> <b>Colore:</b> bianco e colorato		<b>Particle size:</b> 0,9 - 1mm <b>Equipment:</b> steel spatula <b>Dilution:</b> ready to use <b>Coverage</b> (1 coat): 1,5-1,6 kg/m <sup>2</sup> - Per packaging (25 kg): 16,5 m <sup>2</sup> <b>Color:</b> white and colored		<b>Granulometría:</b> 0,9 - 1mm <b>Herramientas:</b> espátula de acero <b>Dilución:</b> listo para usar <b>Rendimiento</b> (1 capa): 1,5-1,6 kg/m <sup>2</sup> - Por envase (25 kg): 16,5 m <sup>2</sup> <b>Color:</b> blanco y colorido	

tecniche	certificazioni	proprietà	tecnologie
WATER BASED TROWEL READY TO USE	CE EN 15824	BREATHABLE	plus flex 5 cig protect 4

## intonachino idrosiliconico plus g08



scheda  
tecnica



data  
sheet



ficha  
técnica



<p>polisilossano ad effetto intonachino - 0.8 mm</p> <p><b>esterno</b></p>	<p>coating with a polysiloxane intonachino effect - 0.8 mm</p> <p><b>outdoor</b></p>	<p>efecto intonachino polisiloxano - 0.8 mm</p> <p><b>exterior</b></p>
<p>Rivestimento all'acqua a spessore a base di resine polisilossaniche. Caratterizzato da elevata traspirabilità, resistenza alle intemperie, ritenzione di sporco e basso assorbimento d'acqua. Si presta per rinnovare supporti con vecchie pitture o irregolari conferendo protezione e durabilità. Film protetto dall'attacco di alghe, funghi e muffe. Per uso professionale.</p>	<p>Thick water-based coating containing polysiloxane resins. Features high breathability and resistance to bad weather, dirt retention and low water absorption. Lends itself to renovating substrates with old or uneven paint, protecting them and ensuring durability. Film protected against mould, algae, and fungi. For professional use.</p>	<p>Revestimiento de espesor al agua a base de resinas polisiloxánicas. Caracterizado por su gran transpirabilidad, resistencia a la intemperie, retención de la suciedad y baja absorción de agua. Idóneo para renovar soportes con pintura vieja o irregular, proporcionando protección y durabilidad. Película protectora contra el ataque de algas, hongos y mohos. Para uso profesional.</p>
<p><b>Granulometria:</b> 0,8 - 1 mm <b>Attrezzatura:</b> spatola metallica, plastica, finitura con frattazzo di spugna <b>Diluizione:</b> pronto all'uso <b>Resa</b> (2 mani): 1,3-1,6 kg/m<sup>2</sup> - Per confezione (25 kg): 19 m<sup>2</sup> <b>Colore:</b> bianco e colorato</p>	<p><b>Particle size:</b> 0,8 - 1 mm <b>Equipment:</b> metal spatula, plastic, finish with sponge trowel <b>Dilution:</b> ready to use <b>Coverage</b> (2 coats): 1,3-1,6 kg/m<sup>2</sup> - Per packaging (25 kg): 19 m<sup>2</sup> <b>Color:</b> white and colored</p>	<p><b>Granulometría:</b> 0,8 - 1 mm <b>Herramientas:</b> llana metálica, llana de plástico, llana de esponja <b>Dilución:</b> listo para usar <b>Rendimiento</b> (2 capas): 1,3-1,6 kg/m<sup>2</sup> - Por envase (25 kg): 19 m<sup>2</sup> <b>Color:</b> blanco y colorido</p>

<p><b>tecniche</b></p>	<p><b>certificazioni</b></p>	<p><b>proprietà</b></p>	<p><b>tecnologie</b></p>
------------------------	------------------------------	-------------------------	--------------------------

## intonachino idrosiliconico plus g06



scheda  
tecnica



data  
sheet



ficha  
técnica



<p>polisilossano ad effetto intonachino - 0.6 mm</p> <p><b>esterno</b></p>	<p>coating with a polysiloxane intonachino effect - 0.6 mm</p> <p><b>outdoor</b></p>	<p>efecto intonachino polisiloxano - 0.6 mm</p> <p><b>exterior</b></p>
<p>Rivestimento all'acqua a spessore a base di resine polisilossaniche. Caratterizzato da elevata traspirabilità, resistenza alle intemperie, ritenzione di sporco e basso assorbimento d'acqua. Si presta per rinnovare supporti con vecchie pitture o irregolari conferendo protezione e durabilità. Film protetto dall'attacco di alghe, funghi e muffe. Per uso professionale.</p>	<p>Thick water-based coating containing polysiloxane resins. Features high breathability and resistance to bad weather, dirt retention and low water absorption. Lends itself to renovating substrates with old or uneven paint, protecting them and ensuring durability. Film protected against mould, algae, and fungi. For professional use.</p>	<p>Revestimiento de espesor al agua a base de resinas polisiloxánicas. Caracterizado por su gran transpirabilidad, resistencia a la intemperie, retención de la suciedad y baja absorción de agua. Idóneo para renovar soportes con pintura vieja o irregular, proporcionando protección y durabilidad. Película protectora contra el ataque de algas, hongos y mohos. Para uso profesional.</p>
<p><b>Granulometria:</b> 0,6 mm <b>Attrezzatura:</b> spatola metallica, plastica, finitura con frattazzo di spugna <b>Diluizione:</b> pronto all'uso <b>Resa</b> (2 mani): 1,3-1,6 kg/m<sup>2</sup> - Per confezione (25 kg): 20 m<sup>2</sup> <b>Colore:</b> bianco e colorato</p>	<p><b>Particle size:</b> 0,6 mm <b>Equipment:</b> metal spatula, plastic, finish with sponge trowel <b>Dilution:</b> ready to use <b>Coverage</b> (2 coats): 1,3-1,6 kg/m<sup>2</sup> - Per packaging (25 kg): 20 m<sup>2</sup> <b>Color:</b> white and colored</p>	<p><b>Granulometría:</b> 0,6 mm <b>Herramientas:</b> llana metálica, llana de plástico, llana de esponja <b>Dilución:</b> listo para usar <b>Rendimiento</b> (2 capas): 1,3-1,6 kg/m<sup>2</sup> - Por envase (25 kg): 20 m<sup>2</sup> <b>Color:</b> blanco y colorido</p>

<p><b>tecniche</b></p>	<p><b>certificazioni</b></p>	<p><b>proprietà</b></p>	<p><b>tecnologie</b></p>
------------------------	------------------------------	-------------------------	--------------------------

## rivasil g15

scheda  
tecnicadata  
sheetficha  
técnicarivestimento minerale  
ai silicati - 1.5 mm**esterno**mineral coating with  
silicates - 1.5 mm**outdoor**revestimiento mineral  
con silicatos - 1.5 mm**exterior**

Rivestimento minerale a spessore continuo, formulato con silicato alcalino a norma DIN 18363. Formulato in modo da assicurare traspirabilità al vapore, resistenza alle intemperie, alla luce e agli agenti inquinanti in genere. Differisce dai normali rivestimenti plastici continui in quanto la superficie che si ottiene ha un aspetto pieno ed uniforme. Per uso professionale.

Continuous thick mineral coating formulated with alkaline silicate in accordance with DIN 18363. Formulated to guarantee vapour permeability, resistant to bad weather, light and pollutants in general. It differs from normal continuous plastic coatings because it achieves a full, uniform surface. For professional use.

Revestimiento mineral de espesor continuo, formulado con silicato alcalino conforme a la norma DIN 18363. Formulato para asegurar la transpirabilidad al vapor, resistencia a la intemperie, a la luz y a los agentes contaminantes en general. Se diferencia de los revestimientos plásticos de espesor continuo más comunes en que la superficie que se obtiene presenta un aspecto pleno y uniforme. Para uso profesional.

**Granulometria:** max 1,5 mm  
**Attrezzatura:** frattazzo metallico o plastico  
**Diluizione:** pronto all'uso  
**Resa** (1 mano): 3 kg/m<sup>2</sup> - Per confezione (25 kg): 8,3 m<sup>2</sup>  
**Colore:** bianco e colorato

**Particle size:** max 1,5 mm  
**Equipment:** metal or plastic trowel  
**Dilution:** ready to use  
**Coverage** (1 coat): 3 kg/m<sup>2</sup> - Per packaging (25 kg): 8,3 m<sup>2</sup>  
**Color:** white and colored

**Granulometría:** max 1,5 mm  
**Herramientas:** llana metálica, llana de plástico  
**Dilución:** listo para usar  
**Rendimiento** (1 capa): 3 kg/m<sup>2</sup> - Por envase (25 kg): 8,3 m<sup>2</sup>  
**Color:** blanco y colorido

## tecniche



COLOURABLE

WATER  
BASED

TROWEL

READY  
TO USE

## certificazioni

CE  
EN 15824

## proprietà



MINERAL

VI  
BREATHABLE

## tecnologie

silicate  
3

## rivasil g12

scheda  
tecnicadata  
sheetficha  
técnicarivestimento minerale  
ai silicati - 1.2 mm**esterno**mineral coating with  
silicates - 1.2 mm**outdoor**revestimiento mineral  
con silicatos - 1.2 mm**exterior**

Rivestimento minerale a spessore continuo, formulato con silicato alcalino a norma DIN 18363. Formulato in modo da assicurare traspirabilità al vapore, resistenza alle intemperie, alla luce e agli agenti inquinanti in genere. Differisce dai normali rivestimenti plastici continui in quanto la superficie che si ottiene ha un aspetto pieno ed uniforme. Per uso professionale.

Continuous thick mineral coating formulated with alkaline silicate in accordance with DIN 18363. Formulated to guarantee vapour permeability, resistant to bad weather, light and pollutants in general. It differs from normal continuous plastic coatings because it achieves a full, uniform surface. For professional use.

Revestimiento mineral de espesor continuo, formulado con silicato alcalino conforme a la norma DIN 18363. Formulato para asegurar la transpirabilidad al vapor, resistencia a la intemperie, a la luz y a los agentes contaminantes en general. Se diferencia de los revestimientos plásticos de espesor continuo más comunes en que la superficie que se obtiene presenta un aspecto pleno y uniforme. Para uso profesional.

**Granulometria:** max 1,2 mm  
**Attrezzatura:** frattazzo metallico o plastico  
**Diluizione:** pronto all'uso  
**Resa** (1 mano): 2,2 kg/m<sup>2</sup> - Per confezione (25 kg): 11,4 m<sup>2</sup>  
**Colore:** bianco e colorato

**Particle size:** max 1,2 mm  
**Equipment:** metal or plastic trowel  
**Dilution:** ready to use  
**Coverage** (1 coat): 2,2 kg/m<sup>2</sup> - Per packaging (25 kg): 11,4 m<sup>2</sup>  
**Color:** white and colored

**Granulometría:** max 1,2 mm  
**Herramientas:** llana metálica, llana de plástico  
**Dilución:** listo para usar  
**Rendimiento** (1 capa): 2,2 kg/m<sup>2</sup> - Por envase (25 kg): 11,4 m<sup>2</sup>  
**Color:** blanco y colorido

## tecniche



COLOURABLE

WATER  
BASED

TROWEL

READY  
TO USE

## certificazioni

CE  
EN 15824

## proprietà



MINERAL

VI  
BREATHABLE

## tecnologie

silicate  
3



# ivasil intonachino g08



scheda  
tecnica



data  
sheet



ficha  
técnica



rivestimento ai silicati ad effetto intonachino - 0.8 mm <b>esterno</b>	rivestimento ai silicati ad effetto intonachino - 0.8 mm <b>outdoor</b>	revestimiento de efecto intonachino con silicatos - 0.8 mm <b>exterior</b>
Rivestimento minerale a base di silicato di potassio alcalino in soluzione acquosa, pigmenti naturali e graniglie di marmo che ne conferiscono spessore e lo rendono atto a livellare supporti irregolari. Formulato specificatamente per edifici di interesse storico e come finitura cicli deumidificanti. Per uso professionale	Mineral coating based on alkaline potassium silicate in a water-based solution, natural pigments and marble granules that provide thickness and make it ideal for levelling irregular substrates. Specifically formulated for historic buildings and as a topcoat for dehumidifying processes. For professional use.	Revestimiento mineral a base de silicato de potasio alcalino en solución acuosa, pigmentos naturales y granallas de mármol que le dan espesor y lo hacen idóneo para nivelar soportes irregulares. Formulado específicamente para edificios de interés histórico y como acabado para ciclos deshumidificantes. Para uso profesional.
<b>Granulometria:</b> 0,8 - 1 mm <b>Attrezzatura:</b> frattazzo metallico, plastico o di spugna <b>Diluizione:</b> pronto all'uso <b>Resa</b> (1 mano): 1,25 kg/m <sup>2</sup> - Per confezione (25 kg): 19,2 m <sup>2</sup> <b>Colore:</b> bianco e colorato	<b>Particle size:</b> 0,8 - 1 mm <b>Equipment:</b> metal, plastic or sponge trowel <b>Dilution:</b> ready to use <b>Coverage</b> (1 coat): 1,25 kg/m <sup>2</sup> - Per packaging (25 kg): 19,2 m <sup>2</sup> <b>Color:</b> white and colored	<b>Granulometría:</b> 0,8 - 1 mm <b>Herramientas:</b> llana metálica, llana de plástico, llana de esponja <b>Dilución:</b> listo para usar <b>Rendimiento</b> (1 capa): 1,25 kg/m <sup>2</sup> - Por envase (25 kg): 19,2 m <sup>2</sup> <b>Color:</b> blanco y colorido

tecniche			certificazioni			proprietà			tecnologie		





# exterior

**rivestimenti e finiture**

# prodotti

finquarz  
quarzoplast  
graffiato  
rugoplast

Dr

## finquarz



scheda  
tecnica



data  
sheet



ficha  
técnica



idropittura al quarzo	esterno	water-based quartz paint	outdoor	pintura al agua con cuarzo	exterior
<p>Microrivestimento con farina di quarzo, a base di resine viniliche. Finitura riempitiva di aspetto opaco, insensibile all'alcalinità del supporto; resistente alla proliferazione di muffe; resistente agli agenti atmosferici pur permettendo traspirabilità. Per uso professionale.</p>		<p>Quartz flour-based micro-coating with vinyl resins. Filler topcoat, insensitive to the alkalinity of the substrate; resistant to the proliferation of mould and mildew; resistant to the weather while still ensuring breathability. Matt finish For professional use.</p>		<p>Micro-revestimiento con harina de cuarzo, a base de resinas vinílicas. Acabado de relleno de aspecto mate, insensible a la alcalinidad del soporte; resistente a la proliferación de mohos; resistente a los agentes atmosféricos y transpirante al mismo tiempo. Para uso profesional.</p>	
<p><b>Attrezzatura:</b> pennello, rullo, airless <b>Diluizione:</b> acqua - prima mano: 20-30%, seconda mano: 15-20% <b>Resa</b> (2 mani): 3-4 m<sup>2</sup>/l - Per confezione (14 l): 56 m<sup>2</sup> <b>Colore:</b> bianco e colorato</p>		<p><b>Equipment:</b> brush, roller, airless <b>Dilution:</b> water - 1°coat: 20-30%, 2°coat: 15-20% <b>Coverage</b> (2 coats): 3-4 m<sup>2</sup>/l - Per packaging (14 l): 56 m<sup>2</sup> <b>Color:</b> white and colored</p>		<p><b>Herramientas:</b> brocha, rodillo, pistola pulverizadora <b>Dilución:</b> agua - 1° capa: 20-30%, 2° capa: 15-20% <b>Rendimiento</b> (2 capas): 3-4 m<sup>2</sup>/l - Por envase (14 l): 56 m<sup>2</sup> <b>Color:</b> blanco y colorido</p>	

### tecniche



### certificazioni

### proprietà



### tecnologie

## quarzoplast



scheda  
tecnica



data  
sheet



ficha  
técnica



rivestimento plastico continuo ad effetto bucciato	esterno	continuous plastic coating with orange-peel effect	outdoor	revestimiento plástico continuo de efecto moteado	exterior
<p>Rivestimento plastico ad effetto bucciato. A base di resine acriliche in dispersione, additivi vari atti a facilitare l'applicazione e la filmazione, sabbie quarzifere a diversa granulometria che ne conferiscono il caratteristico aspetto bucciato. Per uso professionale.</p>		<p>Plastic coating with orange-peel effect. Based on acrylic resins in dispersion, contains various additives to facilitate application and film-formation as well as quartz sand of various particle size to create the characteristic orange-peel effect. For professional use.</p>		<p>Revestimiento plástico de efecto moteado. A base de resinas acrílicas en dispersión, aditivos varios con la función de facilitar la aplicación y la formación de película, arenas de cuarzo de distintas granulometrías que le proporcionan su característico aspecto moteado. Para uso profesional.</p>	
<p><b>Attrezzatura:</b> pennello, rullo e frattazzo metallico o plastico <b>Diluizione:</b> pronto all'uso <b>Resa</b> (1 mano): 1,25 m<sup>2</sup>/l - Per confezione (14 l): 17,5 m<sup>2</sup> <b>Colore:</b> bianco e colorato</p>		<p><b>Equipment:</b> brush, roller e metal or plastic trowel <b>Dilution:</b> ready to use <b>Coverage</b> (1 coat): 1,25 m<sup>2</sup>/l - Per packaging (14 l): 17,5 m<sup>2</sup> <b>Color:</b> white and colored</p>		<p><b>Herramientas:</b> brocha, rodillo, llana metálica, llana de plástico <b>Dilución:</b> listo para usar <b>Rendimiento</b> (1 capa): 1,25 m<sup>2</sup>/l - Por envase (14 l): 17,5 m<sup>2</sup> <b>Color:</b> blanco y colorido</p>	

### tecniche



### certificazioni



### proprietà



### tecnologie



## graffiato



scheda  
tecnica



data  
sheet



ficha  
técnica



rivestimento plastico continuo ad effetto graffiato <b>esterno</b>	continuous plastic coating with scratched effect <b>outdoor</b>	revestimiento plástico continuo de efecto rayado <b>exterior</b>
Rivestimento plastico continuo che riproduce il caratteristico effetto graffiato. A base di emulsione di resine sintetiche, sabbie quarzifere a diversa granulometria ed additivi atti a facilitare l'applicazione e la filmazione, pigmenti colorati resistenti alla luce ed alle condizioni atmosferiche più gravose. Per uso professionale.	Continuous plastic coating that reproduces a conventional scratched effect. Based on an emulsion of synthetic resins, quartz sands of different particle sizes and additives to facilitate application and film forming, coloured pigments resistant to light and to the most severe atmospheric conditions. For professional use.	Revestimiento plástico continuo que reproduce el característico efecto rayado. A base de emulsión de resinas sintéticas, arenas de cuarzo de distintas granulometrías y aditivos con la función de facilitar la aplicación y la formación de película, pigmentos de color resistentes a la luz y a las condiciones atmosféricas más exigentes. Para uso profesional.
<b>Granulometria:</b> max 1,7 mm <b>Attrezzatura:</b> frattazzo metallico o plastico <b>Diluizione:</b> pronto all'uso <b>Resa</b> (1 mano): 3 kg/m <sup>2</sup> - Per confezione (25 kg): 8,3 m <sup>2</sup> <b>Colore:</b> bianco e colorato	<b>Particle size:</b> max 1,7 mm <b>Equipment:</b> metal or plastic trowel <b>Dilution:</b> ready to use <b>Coverage</b> (1 coat): 3 kg/m <sup>2</sup> - Per packaging (25 kg): 8,3 m <sup>2</sup> <b>Color:</b> white and colored	<b>Granulometría:</b> max 1,7 mm <b>Herramientas:</b> llana metálica, llana de plástico <b>Dilución:</b> listo para usar <b>Rendimiento</b> (1 capa): 3 kg/m <sup>2</sup> - Por envase (25 kg): 8,3 m <sup>2</sup> <b>Color:</b> blanco y colorido

tecniche	certificazioni	proprietà	tecnologie

## rugoplast



scheda  
tecnica



data  
sheet



ficha  
técnica



rivestimento plastico continuo mascherante <b>esterno</b>	continuous plastic coating with masking effect <b>outdoor</b>	revestimiento plástico continuo de efecto máscara <b>exterior</b>
Rivestimento indicato per mascherare le disuniformità del supporto, dotato di buona elasticità, può essere applicato in forti spessori senza evidenziare screpolature. A base di resine viniliche in dispersione, graniglie di marmo e sabbie quarzifere, speciali additivi che lo rendono idrorepellente e ne conferiscono il caratteristico aspetto. Per uso professionale.	Ideal for covering unevenness in the substrates. Given its good elasticity, it can be applied in very thick coats without showing cracking. Based on vinyl resins in dispersion, marble granules and quartz sand, with special additives that make it water-repellent and impart its characteristic appearance. For professional use.	Revestimiento idóneo para enmascarar problemas de falta de uniformidad en el soporte; su buena elasticidad permite su aplicación en espesores gruesos sin mostrar cuarteados. A base de resinas vinílicas en dispersión, granallas de mármol y arenas de cuarzo, aditivos especiales que lo hacen hidro-repellente y le proporcionan su aspecto característico. Para uso profesional.
<b>Granulometria:</b> max 0,6 mm <b>Attrezzatura:</b> frattazzo metallico, rullo di spugna a nido d'ape <b>Diluizione:</b> pronto all'uso <b>Resa</b> (1 mano): 3-3,5 kg/m <sup>2</sup> - Per confezione (25 kg): 8,3 m <sup>2</sup> <b>Colore:</b> bianco e colorato	<b>Particle size:</b> max 0,6 mm <b>Equipment:</b> metal trowel, sponge, honeycomb roller <b>Dilution:</b> ready to use <b>Coverage</b> (1 coat): 3-3,5 kg/m <sup>2</sup> - Per packaging (25 kg): 8,3 m <sup>2</sup> <b>Color:</b> white and colored	<b>Granulometría:</b> max 0,6 mm <b>Herramientas:</b> llana metálica, rodillo de esponja alveolar <b>Dilución:</b> listo para usar <b>Rendimiento</b> (1 capa): 3-3,5 kg/m <sup>2</sup> - Por envase (25 kg): 8,3 m <sup>2</sup> <b>Color:</b> blanco y colorido

tecniche	certificazioni	proprietà	tecnologie

	prodotto	caratteristiche principali
PAINT HT	<b>silox plus</b> pag. 52	idropittura polisilossanica a effetto vellutato
	<b>superquarz plus</b> pag. 53	idropittura acrilsilossanica con farina di quarzo
	<b>ultra dry</b> pag. 53	pittura idrorepellente protettiva
	<b>superclean plus</b> pag. 53	idropittura autopulente ad effetto fotocatalitico
	<b>superquarz plus strong</b> pag. 54	idropittura al quarzo per colori intensi
	<b>superquarz plus reflect</b> pag. 54	idropittura al quarzo riflettente
	<b>ivasgum side finitura</b> pag. 55	pittura elastomerica
	<b>quarzogum plus</b> pag. 55	pittura elastomerica riempitiva al quarzo
	<b>idrobeton</b> pag. 56	pittura anticarbonatazione
	<b>ivasil pittura</b> pag. 56	idropittura minerale ai silicati
	<b>deco sand plus</b> pag. 57	idropittura mascherante ad effetto decorativo sabbiato
	<b>ivaglass lucido/opaco</b> pag. 58	smalto bicomponente acrilpoliuretano
<b>betonglass lucido/opaco</b> pag. 59	smalto bicomponente acrilpoliuretano per CLS	

EXTERIOR HT	<b>intogum g12</b> pag. 62	rivestimento a spessore elastomerico - 1.2 mm
	<b>intogum g10</b> pag. 62	rivestimento a spessore elastomerico - 1 mm
	<b>intonachino idrosiliconico g08</b> pag. 63	rivestimento polisilossano ad effetto intonachino - 0.8 mm
	<b>intonachino idrosiliconico g06</b> pag. 63	rivestimento polisilossano ad effetto intonachino - 0.6 mm
	<b>rivasil g15</b> pag. 64	rivestimento minerale ai silicati 1.5 mm
	<b>rivasil g12</b> pag. 64	rivestimento minerale ai silicati - 1.2 mm
	<b>ivasil intonachino g08</b> pag. 65	rivestimento ai silicati ad effetto intonachino - 0.8 mm

EXTERIOR	<b>finquarz</b> pag. 68	idropittura al quarzo
	<b>quarzoplast</b> pag. 68	rivestimento plastico continuo ad effetto bucciato
	<b>graffiato</b> pag. 69	rivestimento plastico continuo ad effetto graffiato
	<b>rugoplast</b> pag. 69	rivestimento plastico continuo mascherante

destinazione d'uso	colori	traspirabilità	brillantezza	altro	tecnologie	certificazioni
esterno	YouColor®	V1	---	---	plus; silox 5	A+; muffe alghe batteri
esterno	YouColor®	V2	---	---	plus; silox 3	A+; muffe alghe
esterno	YouColor®	V2	---	---	dry; plus; resist 4	---
esterno	YouColor®	V2	---	---	clean; plus; silox 5	A+; muffe alghe batteri
esterno	YouColor®	V2	---	---	strong; plus	---
esterno	colorato	V2	---	---	reflect; plus	---
esterno	YouColor®	V2	---	---	flex 5; cls protect 3; resist 3	---
esterno	YouColor®	V2	---	---	plus; flex 3, cls protect 3	---
interno / esterno	YouColor®	V2	---	---	cls protect 5; resist 4	A+
interno / esterno	YouColor®	V1	---	mineral	silicate 4	---
interno / esterno	YouColor®	V2	---	---	plus; silox 3	---
interno / esterno	YouColor®	---	---	---	resist 5	---
interno / esterno	colorato	---	---	---	resist 5	---
		---	---	---		
esterno	colorato	V1	---	---	plus; fex 5; cls protect 4	CE EN 15824
esterno	colorato	V1	---	---	plus; fex 5; cls protect 4	CE EN 15824
esterno	YouColor®	V1	---	---	plus; siloxan 4	CE EN 15824
esterno	YouColor®	V1	---	---	plus; siloxan 4	CE EN 15824
esterno	YouColor®	V1	---	mineral	silicate 3	CE EN 15824
esterno	YouColor®	V1	---	mineral	silicate 3	CE EN 15824
esterno	colorato	V1	---	mineral	silicate 4	CE EN 15824
						---
esterno	YouColor®	---	matt	---	---	---
esterno	colorato	V2	matt	---	flex 3	---
esterno	YouColor®	---	---	pronto uso	---	---
esterno	colorato	---	---	pronto uso	---	---



**anticarbonatazione - anticarbonation - anti-carbonatación**

consolidamento / imprimitura consolidation/ priming consolidación / imprimación	finitura finish acabado
<b>primacril</b> pag.80	<b>idrobeton</b> pag.56

**per cavillature max 100 µ - for fine-tuning up to 100 µ - para fisuración máx. 100 µ**

consolidamento / imprimitura consolidation/ priming consolidación / imprimación	strato uniformante uniforming layer capa uniformadora	finitura finish acabado
<b>nitrofix</b> pag. 80 oppure <b>primacril</b> pag. 80	<b>rasofondo flex</b> pag. 77	<b>quarzogum plus</b> pag. 55

**per cavillature max 1 mm - for fine-tuning up to 1 mm - para fisuración máx. 1 mm**

consolidamento / imprimitura consolidation/ priming consolidación / imprimación	strato uniformante uniforming layer capa uniformadora	finitura finish acabado
<b>nitrofix</b> pag. 80 oppure <b>primacril</b> pag. 80	<b>ivasgum fondo</b> pag. 77	<b>ivasgum side finitura</b> pag. 55 oppure <b>intogum plus</b> pag. 62

**per cavillature max 2 mm - for fine-tuning up to 2 mm - para fisuración máx. 2 mm**

risanamento restoration acabado	consolidamento / imprimitura consolidation/ priming consolidación / imprimación	strato uniformante uniforming layer capa uniformadora	rete mesh malla	finitura finish acabado
<b>elastucco</b> pag. 84	<b>nitrofix</b> pag. 80 oppure <b>primacril</b> pag. 80	<b>ivasgum fondo</b> pag. 77	<b>armatex micro</b> pag. 112	<b>ivasgum side finitura</b> pag. 55 oppure <b>intogum plus</b> pag. 62

**antialga, antimuffa - anti alga, anti mold - antimoho, antialgas**

risanamento restoration acabado	consolidamento / imprimitura consolidation/ priming consolidación / imprimación	finitura finish acabado
<b>sana solux</b> pag.41	<b>nitrofix</b> pag. 80 oppure <b>primacril</b> pag.80	<b>superquarz plus</b> pag. 52 oppure <b>silox plus</b> pag.52 oppure <b>ultra dry</b> pag. 53

**minerali ai silicati - silicate minerals - minerales de silicato**

consolidamento / imprimitura consolidation/ priming consolidación / imprimación	strato uniformante uniforming layer capa uniformadora	finitura finish acabado
<b>ivasil primer s</b> pag.81	<b>ivasil fondo</b> pag.77	<b>ivasil pittura</b> pag. 56 oppure <b>ivasil intonachino</b> pag. 65 oppure <b>rivasil</b> pag. 64

**mascherante uniformante decorativo - decorative uniform concealer - enmascaramiento uniformador decorativo**

consolidamento / imprimitura consolidation/ priming consolidación / imprimación	finitura finish acabado
<b>silofix</b> pag.80	<b>deco sand plus</b> pag.57

**fotocatalitico, autopulente - photocatalytic, self-cleaning - fotocatalítico, autolimpiante**

consolidamento / imprimitura consolidation/ priming consolidación / imprimación	finitura finish acabado
<b>silofix</b> pag.80	<b>superclean plus</b> pag.53



# fondi

**fondi uniformanti**

# prodotti

rasofondo color

prime tech

rasofondo flex

ivasgum fondo

ivasil fondo





## rasofondo color

scheda  
tecnicadata  
sheetficha  
técnica

fondo uniformante pigmentato	interno esterno	pigmented uniforming base coat	indoor outdoor	fondo uniformante pigmentado	interior exterior
Fondo riempitivo uniformante a grana fine a base di resine acrililossaniche e farine di quarzo in dispersione acquosa. Ideale come mano di fondo per idropitture al fine di uniformare gli assorbimenti e la tenuta dei colori. Caratterizzato da ottimo potere riempitivo, elevata copertura, elevata traspirabilità. Per uso professionale.		Uniforming filler base coat based on acrylic resins and quartz flours in water dispersion, suitable for uniforming old patched plasters or for making smooth skimmed surfaces rough. Ideal as a base coat for water-based paints. Characterized by excellent filling power, high coverage and high breathability. For professional use.		Fondo de relleno uniformante a base de resinas acrílicas y harinas de cuarzo en dispersión acuosa, indicado para uniformar enfoscados viejos reparados o para dar rugosidad a superficies enrasadas lisas. Ideal como capa de fondo para pinturas al agua. Caracterizado por su excelente capacidad de relleno, alto nivel cubriente y alta transpirabilidad. Para uso profesional.	
<b>Granulometria:</b> 75 µ <b>Attrezzatura:</b> pennello, rullo a pelo corto <b>Diluizione:</b> acqua - 15-20% <b>Resa</b> (2 mani): 3-4 m <sup>2</sup> /l - Per confezione (14 l): 56 m <sup>2</sup> <b>Colore:</b> bianco e colorato		<b>Particle size:</b> 75 µ <b>Equipment:</b> brush, roller <b>Dilution:</b> water - 15-20% <b>Coverage</b> (2 coats): 3-4 m <sup>2</sup> /l - Per packaging (14 l): 56 m <sup>2</sup> <b>Color:</b> white and colored		<b>Granulometría:</b> 75 µ <b>Herramientas:</b> brocha, rodillo a pelo corto <b>Dilución:</b> agua - 15-20% <b>Rendimiento</b> (2 capas): 3-4 m <sup>2</sup> /l - Por envase (14 l): 56 m <sup>2</sup> <b>Color:</b> blanco y colorido	

tecniche	certificazioni	proprietà	tecnologie
   			

## prime tech

scheda  
tecnicadata  
sheetficha  
técnica

fondo all'acqua liscio opaco - pronto uso	interno	water-based, smooth matt base coat with pigments	indoor	fondo al agua liso mate pigmentado	interiores
Fondo all'acqua extrafine opaco pronto uso a base di resine vinilversatiche, cariche minerali inerti, pigmenti selezionati. Uniforma la superficie del supporto al fine di ottimizzare l'applicazione del prodotto di finitura. Ideale come mano di fondo per cartongesso per successive finiture linea idropitture, lavabili e idrosmalti. Si consiglia applicazione di idoneo primer su supporti sfarinanti. Per uso professionale.		Extra-fine water-based matt base coat containing vinylversatic resins, inert mineral fillers and selected pigments. It smooths out the surface of the substrate, thus optimizing application of the topcoat. Ideal for plasterboard after a suitable primer has been applied. We recommend the application of suitable primer on flakes. For professional use.		Fondo al agua extrafino mate a base de resinas vinilversatic, cargas minerales inertes, pigmentos seleccionados. Uniforma la superficie del soporte a fin de optimizar la aplicación del producto de acabado. Ideal para cartón-yeso previa aplicación de una imprimación adecuada. Se recomienda la aplicación de cebadores adecuados en soportes con desintegración pulverulenta. Para uso profesional.	
<b>Granulometria:</b> 45 µ <b>Attrezzatura:</b> pennello, rullo, airless <b>Diluizione:</b> pronto uso <b>Resa</b> (1 mano): 5-6 m <sup>2</sup> /l - Per confezione (14 l): 84 m <sup>2</sup> <b>Colore:</b> solo bianco		<b>Particle size:</b> 45 µ <b>Equipment:</b> brush, roller, airless <b>Dilution:</b> ready to use <b>Coverage</b> (1 coat): 5-6 m <sup>2</sup> /l - Per packaging (14 l): 84 m <sup>2</sup> <b>Color:</b> only white		<b>Granulometría:</b> 45 µ <b>Herramientas:</b> brocha, rodillo, pistola pulverizadora <b>Dilución:</b> listo para usar <b>Rendimiento</b> (1 capa): 5-6 m <sup>2</sup> /l - Por envase (14 l): 84 m <sup>2</sup> <b>Color:</b> solo blanco	

tecniche	certificazioni	proprietà	tecnologie
    			

## rasofondo flex



scheda  
tecnica



data  
sheet



ficha  
técnica



fondo riempitivo uniformante polisilossanico	interno esterno	polysiloxanic uniforming filler base coat	indoor outdoor	fondo de relleno uniformante polisiloxánico	interior exterior
Rivestimento di fondo deformabile a base di resine acrilisilossaniche elastomeriche in dispersione acquosa granulometria 0.5mm. Possiede elevata flessibilità, elevata traspirabilità, basso assorbimento d'acqua, ottimo potere riempitivo ed elevata copertura. Ideale per uniformare la granulometria dei supporti e in esterno per superfici microcavillate. Per uso professionale.		Deformable base coat containing acrylic-siloxane-elastomeric resins in water dispersion with 0.5mm grain size. Offers great flexibility, high breathability, low water absorption, superb filling and high coverage. Ideal to even out of the particle size of the substrates and outdoors for surfaces presenting micro-cracks. For professional use.		Revestimiento de fondo deformable a base de resinas acrilisiloxánicas elastoméricas en dispersión acuosa con granulometría de 0,5 mm. Posee una elevada flexibilidad, alta transpirabilidad, baja absorción de agua, excelente capacidad de relleno y alto nivel cubriente. Ideal para dar uniformidad a la granulometría de los soportes y exteriores para superficies microcuartheadas. Para uso profesional.	
<b>Granulometria:</b> 0,5 mm <b>Attrezzatura:</b> pennello, rullo a pelo corto <b>Diluizione:</b> acqua - 12-15% <b>Resa</b> (1 mano): 3,5-4 m <sup>2</sup> /l - Per confezione (14 l): 56 m <sup>2</sup> <b>Colore:</b> solo bianco		<b>Particle size:</b> 0,5 mm <b>Equipment:</b> brush, roller <b>Dilution:</b> water - 12-15% <b>Coverage</b> (1 coat): 3,5-4 m <sup>2</sup> /l - Per packaging (14 l): 56 m <sup>2</sup> <b>Color:</b> only white		<b>Granulometría:</b> 0,5 mm <b>Herramientas:</b> brocha, rodillo a pelo corto <b>Dilución:</b> agua - 12-15% <b>Rendimiento</b> (1 capa): 3,5-4 m <sup>2</sup> /l - Por envase (14 l): 56 m <sup>2</sup> <b>Color:</b> solo blanco	

tecniche	certificazioni	proprietà	tecnologie
WATER BASED BRUSH ROLLER			flex 5

## ivasgum fondo



scheda  
tecnica



data  
sheet



ficha  
técnica



fondo uniformante elastomerico	esterno	uniforming elastomeric base coat	outdoor	fondo uniformante elastomérico	exterior
Rivestimento di fondo riempitivo elastomerico. Possiede elevate resistenze meccaniche unite ad un'elevata resistenza agli shock termici. La notevole elasticità riduce i rischi di cavillature e screpolature. Abbinato alla rete Armatex Micro è utilizzato come ciclo elastomerico Ivas. Per uso professionale.		Elastomeric filler base coat. High resistance, both mechanical and to abrupt changes in temperature. Its remarkable elasticity reduces the risk of cracks and fissures. In combination with Armatex Micro mesh, it is used as an Ivas elastomeric process. For professional use.		Revestimiento de fondo de relleno elastomérico. Dotado de altas resistencias mecánicas unidas a resistencia a los choques térmicos. Su notable elasticidad reduce los riesgos de cuarteados y grietas. Unido a la malla Armatex Micro se utiliza como ciclo elastomérico Ivas. Para uso profesional.	
<b>Granulometria:</b> 75 µ <b>Attrezzatura:</b> pennello, rullo a pelo corto <b>Diluizione:</b> acqua - max 5% o tal quale <b>Resa</b> (2 mani): 2,5-3 m <sup>2</sup> /l - Per confezione (14 l): 42 m <sup>2</sup> <b>Colore:</b> solo bianco		<b>Particle size:</b> 75 µ <b>Equipment:</b> brush, roller <b>Dilution:</b> water - max 5% o tal quale <b>Coverage</b> (2 coats): 2,5-3 m <sup>2</sup> /l - Per packaging (14 l): 42 m <sup>2</sup> <b>Color:</b> only white		<b>Granulometría:</b> 75 µ <b>Herramientas:</b> brocha, rodillo <b>Dilución:</b> agua - max 5% o tal quale <b>Rendimiento</b> (2 capas): 2,5-3 m <sup>2</sup> /l - Por envase (14 l): 42 m <sup>2</sup> <b>Color:</b> solo blanco	

tecniche	certificazioni	proprietà	tecnologie
WATER BASED BRUSH ROLLER			flex 5

## ivasil fondo



scheda  
tecnica



data  
sheet



ficha  
técnica



fondo uniformante ai silicati	interno esterno	Uniforming silicate base coat	indoor outdoor	fondo uniformante con silicatos	interior exterior
Fondo riempitivo uniformante ai silicati per cicli con elevata traspirabilità al vapore. Particolarmente idoneo per uniformare vecchi intonaci rappezzati, per supporti con esistenti pitture organiche. Ideale come fondo per finiture minerali. Per uso professionale.		Uniforming silicate filler base coat for mineral processes offering high vapour breathability. Particularly suitable for smoothing out old, patched plasters, for substrates with old organic paints. For professional use.		Fondo de relleno uniformante con silicatos para ciclos minerales de gran transpirabilidad al vapor. Particolarmente idoneo para dar uniformidad a enfoscados viejos con reparaciones y para soportes con pinturas orgánicas preexistentes.	
<b>Granulometria:</b> 0,35 mm <b>Attrezzatura:</b> pennello, rullo <b>Diluizione:</b> acqua/Ivasil Primer S - 20-25% <b>Resa</b> (1 mano): 3,5-4 m <sup>2</sup> /l - Per confezione (14 l): 56 m <sup>2</sup> <b>Colore:</b> solo bianco		<b>Particle size:</b> 0,35 mm <b>Equipment:</b> brush, roller <b>Dilution:</b> water/Ivasil Primer S - 20-25% <b>Coverage</b> (1 coat): 3,5-4 m <sup>2</sup> /l - Per packaging (14 l): 56 m <sup>2</sup> <b>Color:</b> only white		<b>Granulometría:</b> 0,35 mm <b>Herramientas:</b> brocha, rodillo <b>Dilución:</b> agua/Ivasil Primer S - 20-25% <b>Rendimiento</b> (1 capa): 3,5-4 m <sup>2</sup> /l - Por envase (14 l): 56 m <sup>2</sup> <b>Color:</b> solo blanco	

tecniche	certificazioni	proprietà	tecnologie
WATER BASED BRUSH ROLLER			silicate 3



**fissativ**

# prodotti

primacril

silofix

nitrofix

acrilica 100

bloccafumo

ivasil primer s

vi

## primacril

scheda  
tecnicadata  
sheetficha  
técnica

fissativo all'acqua ad alta penetrazione	interno esterno	high penetrating, water-based fixative	indoor outdoor	fijador al agua de alto poder penetrante	interior exterior
Fissativo all'acqua ad altissima penetrazione e resistenza agli alcali, formulato per ottenere un'alta protezione suintonaci anche sfarinanti e per uniformare gli assorbimenti. Particolarmente indicato sui supporti in cartongesso. Per uso professionale.		Water-based fixative with utmost penetration and resistance to alkalis, formulated for superb protection on plasters, both indoor and outdoor (including chalky plasters), and to ensure uniform absorption. Particularly suitable for plasterboard substrates. For professional use.		Fijador al agua de máximo poder penetrante, resistente a los álcalis, formulado para obtener una gran protección sobre enfoscados, incluso con desintegración pulverulenta y para uniformar las absorciones. Particolarmente indicado sobre soportes en cartón-yeso. Para uso profesional.	
<b>Attrezzatura:</b> pennello, rullo <b>Diluizione:</b> acqua - 50% <b>Resa</b> (1 mano): 10-12 m <sup>2</sup> /l - Per confezione (25 l): 300 m <sup>2</sup> <b>Colore:</b> incolore		<b>Equipment:</b> brush, roller <b>Dilution:</b> water - 50% <b>Coverage</b> (1 coat): 10-12 m <sup>2</sup> /l - Per packaging (25 l): 300 m <sup>2</sup> <b>Color:</b> colourless		<b>Herramientas:</b> brocha, rodillo <b>Dilución:</b> agua - 50% <b>Rendimiento</b> (1 capa): 10-12 m <sup>2</sup> /l - Por envase (25 l): 300 m <sup>2</sup> <b>Color:</b> incoloro	

## tecniche



## certificazioni

## proprietà

## tecnologie

## silofix

scheda  
tecnicadata  
sheetficha  
técnica

fissativo all'acqua acril-siliconico	esterno	water-based acrylic-silicone fixative	outdoor	fijador al agua acril-silicónico	exterior
Fissativo all'acqua acril-siliconico e polisilossani non filmogeno a particelle estremamente fini. Formulato per ottenere un'alta protezione su calcestruzzi e intonaci esterni anche sfarinanti dando ai supporti idrorepellenza superficiale e di profondità. Particolarmente indicato come primer per successivi cicli altamente traspiranti. Per uso professionale.		Water-based acrylic-silicone fixative with extremely fine, non film-forming polysiloxanes particles. Formulated to achieve superb protection on concrete and external plasters, even when chalky. Makes the substrate water repellent both on the surface and inside. Particularly suitable as primer for subsequent, highly breathable processes. For professional use.		Fijador al agua acril-silicónico con polisiloxanos, no filmógeno, de partículas extremadamente finas. Formulato para obtener una gran protección en hormigones y enfoscados externos, incluso con desintegración pulverulenta, dando a los soportes poder hidro-repelente en la superficie y en profundidad. Particolarmente indicado como imprimación para posteriores ciclos altamente traspirantes. Para uso profesional.	
<b>Attrezzatura:</b> pennello, rullo, airless <b>Diluizione:</b> acqua - 50% <b>Resa</b> (1 mano): 7-8 m <sup>2</sup> /l - Per confezione (25 l): 200 m <sup>2</sup> <b>Colore:</b> incolore		<b>Equipment:</b> brush, roller, airless <b>Dilution:</b> water - 50% <b>Coverage</b> (1 coat): 7-8 m <sup>2</sup> /l - Per packaging (25 l): 200 m <sup>2</sup> <b>Color:</b> colourless		<b>Herramientas:</b> brocha, rodillo, pistola pulverizadora <b>Dilución:</b> agua - 50% <b>Rendimiento</b> (1 capa): 7-8 m <sup>2</sup> /l - Por envase (25 l): 200 m <sup>2</sup> <b>Color:</b> incoloro	

## tecniche



## certificazioni

## proprietà

## tecnologie

## nitrofix

scheda  
tecnicadata  
sheetficha  
técnica

fissativo a solvente ad alta penetrazione	esterno	high penetrating solvent-based fixative	outdoor	fijador con disolvente de alto poder penetrante	exterior
Fissativo trasparente alla Pliolite®, uniformante e consolidante ad elevatissima penetrazione che lo rendono particolarmente idoneo per applicazione su supporti murari esistenti, sfarinanti ed ammalorati. Per uso professionale.		Transparent fixative with Pliolite®, smoothing and consolidating with very high penetration. Ideal for application on old, chalky, deteriorated wall substrates. For professional use.		Fijador trasparente con Pliolite®, uniformante y consolidante de gran poder de penetración que lo hace particularmente idóneo para su aplicación sobre soportes de pared ya existentes, con desintegración pulverulenta y deteriorados. Para uso profesional.	
<b>Attrezzatura:</b> pennello, rullo <b>Diluizione:</b> Diluente Nitro Antinebbia - 10% <b>Resa</b> (1 mano): 8-10 m <sup>2</sup> /l - Per confezione (25 l): 250 m <sup>2</sup> <b>Colore:</b> incolore		<b>Equipment:</b> brush, roller <b>Dilution:</b> Diluente Nitro Antinebbia - 10% <b>Coverage</b> (1 coat): 8-10 m <sup>2</sup> /l - Per packaging (25 l): 250 m <sup>2</sup> <b>Color:</b> colourless		<b>Herramientas:</b> brocha, rodillo <b>Dilución:</b> Diluente Nitro Antinebbia - 10% <b>Rendimiento</b> (1 capa): 8-10 m <sup>2</sup> /l - Por envase (25 l): 250 m <sup>2</sup> <b>Color:</b> incoloro	

## tecniche



## certificazioni

## proprietà

## tecnologie

## acrilica 100



scheda  
tecnica



data  
sheet



ficha  
técnica



fissativo all'acqua ad alta resa	interno esterno	high coverage, water-based fixative	indoor outdoor	fijador al agua de alto rendimiento	interior exterior
<p>Fissativo all'acqua ad alta resa a base di microemulsioni acriliche che conferiscono un alto potere consolidante. Particolarmente indicato suintonaci e pitture esistenti. La Classe TVOC A+ lo rende idoneo per ottemperare i protocolli Leed Breeam. Per uso professionale.</p>		<p>High coverage, water-based fixative with acrylic micro-emulsions that impart high consolidating power. Particularly suitable on old plasters and paints. Classified TVOC A+, it complies with Leed Breeam protocols. For professional use.</p>		<p>Fijador al agua de alto rendimiento a base de microemulsiones acrílicas que le proporcionan una gran capacidad consolidante. Particolarmente indicado sobre enfoscados y pinturas ya existentes. La Clase TVOC A+ la hace idónea para cumplir con los protocolos Leed Breeam. Para uso profesional.</p>	
<p><b>Attrezzatura:</b> pennello, rullo <b>Diluizione:</b> acqua - per impregnazione 400% - per finiture 100-300% <b>Resa prodotto diluito (1 mano):</b> 40-50 m<sup>2</sup>/l - Per confezione (25 l): 1250 m<sup>2</sup> <b>Colore:</b> incolore</p>		<p><b>Equipment:</b> brush, roller <b>Dilution:</b> water - per impregnazione 400% - per finiture 100-300% <b>Coverage diluted product (1 coat):</b> 40-50 m<sup>2</sup>/l - Per packaging (25 l): 1250 m<sup>2</sup> <b>Color:</b> colourless</p>		<p><b>Herramientas:</b> brocha, rodillo <b>Dilución:</b> agua - para impregnación 400% - para acabados 100-300% <b>Rendimiento producto diluido (1 capa):</b> 40-50 m<sup>2</sup>/l - Por envase (25 l): 1250 m<sup>2</sup> <b>Color:</b> incoloro</p>	

tecniche	certificazioni	proprietà	tecnologie
WATER BASED BRUSH ROLLER			

## bloccafumo



scheda  
tecnica



data  
sheet



ficha  
técnica



fissativo all'acqua antifumo	interno	smoke suppressant water-based fixative	indoor	fijador al agua antihumo	interiores
<p>Fissativo trasparente antifumo formulato con specifici leganti in soluzione acquosa che lo rendono idoneo per il trattamento di ambienti con ingiallimenti e macchie di fumo dovuti a stufe caminetti e cucine. particolarmente idoneo come primer per successiva applicazione di Idrofumo. Per uso professionale.</p>		<p>Transparent smoke suppressant fixative formulated with specific binders in a water-based solution. Suitable for the treatment of areas subject to yellowing and smoke stains from heaters, fireplaces and kitchens. Ideal as primer for subsequent application of Idrofumo. For professional use.</p>		<p>Fijador transparente antihumo formulado con aglomerantes específicos en solución acuosa que lo hacen idóneo para el tratamiento de espacios con amarilleo y manchas de humo debidas a estufas, chimeneas y cocinas. Particularmente idóneo como imprimación para la posterior aplicación de Idrofumo. Para uso profesional.</p>	
<p><b>Attrezzatura:</b> pennello, rullo, airless <b>Diluizione:</b> acqua - 20% <b>Resa (1 mano):</b> 6 m<sup>2</sup>/l - Per confezione (25 l): 150 m<sup>2</sup> <b>Colore:</b> incolore</p>		<p><b>Equipment:</b> brush, roller, airless <b>Dilution:</b> water - 20% <b>Coverage (1 coat):</b> 6 m<sup>2</sup>/l - Per packaging (25 l): 150 m<sup>2</sup> <b>Color:</b> colourless</p>		<p><b>Herramientas:</b> brocha, rodillo, pistola pulverizadora <b>Dilución:</b> agua - 20% <b>Rendimiento (1 capa):</b> 6 m<sup>2</sup>/l - Por envase (25 l): 150 m<sup>2</sup> <b>Color:</b> incoloro</p>	

tecniche	certificazioni	proprietà	tecnologie
WATER BASED BRUSH ROLLER			

## ivasil primer s



scheda  
tecnica



data  
sheet



ficha  
técnica



fissativo all'acqua ai silicati	esterno	water-based silicate fixative	outdoor	fijador al agua acrilisilicónico	exterior
<p>Fissativo all'acqua per cicli a base di silicati. Particolarmente idoneo per consolidare intonaci esistenti, rappezzati e per supporti con vecchie pitture organiche. Può essere utilizzato come diluente in Ivasil Pittura e Ivasil Fondo. Conforme alla norma DIN 18363. Per uso professionale.</p>		<p>Water-based silicate fixative for mineral processes. Particularly suitable for consolidating old, patched plasters and substrates with old organic paints. Can also be used as thinner for Ivasil Pittura and Ivasil Fondo. Conforms to DIN 18363. For professional use.</p>		<p>Fijador al agua para ciclos minerales a base de silicatos. Particolarmente idóneo para consolidar enfoscados ya existentes, reparados y para soportes con pinturas orgánicas viejas. Puede utilizarse como diluyente con Ivasil pintura e Ivasil Fondo. Conforme a la norma DIN 18363. Para uso profesional.</p>	
<p><b>Attrezzatura:</b> pennello, rullo <b>Diluizione:</b> pronto all'uso <b>Resa (1 mano):</b> 7-8 m<sup>2</sup>/l - Per confezione (25 l): 190 m<sup>2</sup> <b>Colore:</b> incolore</p>		<p><b>Equipment:</b> brush, roller <b>Dilution:</b> ready to use <b>Coverage (1 coat):</b> 7-8 m<sup>2</sup>/l - Per packaging (25 l): 190 m<sup>2</sup> <b>Color:</b> colourless</p>		<p><b>Herramientas:</b> brocha, rodillo <b>Dilución:</b> listo para usar <b>Rendimiento (1 capa):</b> 7-8 m<sup>2</sup>/l - Por envase (25 l): 190 m<sup>2</sup> <b>Color:</b> incoloro</p>	

tecniche	certificazioni	proprietà	tecnologie
WATER BASED BRUSH ROLLER		MINERAL	SILICATE 5



**stucco**

# prodotti

ivastucco

elastucco

novostucco

stucco in polvere





## ivastucco

scheda  
tecnicadata  
sheetficha  
técnica

stucco in pasta per rasature	interno	skimming plaster in paste form	indoor	emplaste en pasta para enrasados	interiores
Stucco fine per rasature e riempimento, a base di resine sintetiche in dispersione acquosa e riempitivi selezionati, di buona scorrevolezza e spatolabilità, non dà luogo a fessurazioni. Per uso professionale.		Fine skimming and filling plaster based on synthetic resins dispersed in water and selected fillers. Good flow and spreadability. It does not cause cracks. For professional use.		Emplaste fino para enrasados y relleno, a base de resinas sintéticas en dispersión acuosa y rellenos seleccionados, con buenas capacidades de deslizamiento y facilidad para la aplicación con espátula, no causa fisuras. Para uso profesional.	
<b>Attrezzatura:</b> spatola <b>Diluizione:</b> pronto all'uso <b>Resa:</b> 1 kg/m <sup>2</sup> per mm di spessore <b>Colore:</b> solo bianco		<b>Equipment:</b> spatula <b>Dilution:</b> ready to use <b>Coverage:</b> 1 kg/m <sup>2</sup> per mm of thickness <b>Color:</b> only white		<b>Herramientas:</b> espátula <b>Dilución:</b> listo para usar <b>Rendimiento:</b> 1 kg/m <sup>2</sup> per mm de espesor <b>Color:</b> solo blanco	

tecniche	certificazioni	proprietà	tecnologie
 WATER BASED  TROWEL  READY TO USE			

## elastucco

scheda  
tecnicadata  
sheetficha  
técnica

stucco rasante elastico riempitivo	esterno	elastic filler skimming plaster	outdoor	emplaste de enrasado elástico de relleno	exterior
Stucco a base di elastomeri in emulsione acquosa, pigmenti resistenti agli alcali ed alla luce, fibre naturali e sintetiche, extenders. Impiegabile come rasante riempitivo per esterni, elastico ed impermeabile, appositamente formulato per riempimento di fessurazioni o crepe, armabile con Armatex micro. Per uso professionale.		Elastomer-based filler in water emulsion, it contains alkal- and light-resistant pigments, natural and synthetic fibres, extenders. Can be used as elastic, waterproofing filler/skim coat to fill cracks or fissures, for outdoor use. Specially formulated for skimming of plasters with cracks and fissures. Can be used with Armatex micro. For outdoor use. For professional use.		Emplaste a base de elastómeros en emulsión acuosa, pigmentos resistentes a los álcalis y a la luz, fibras naturales y sintéticas, extenders. Puede emplearse como emplaste de enrasado y de relleno para exteriores, elástico e impermeable, específicamente formulado para relleno de fisuras o grietas; puede armarse con Armatex micro. Para uso profesional.	
<b>Attrezzatura:</b> spatola <b>Diluizione:</b> pronto all'uso <b>Resa:</b> 1,4 kg/m <sup>2</sup> per mm di spessore <b>Colore:</b> solo bianco		<b>Equipment:</b> spatula <b>Dilution:</b> ready to use <b>Coverage:</b> 1,4 kg/m <sup>2</sup> per mm of thickness <b>Color:</b> only white		<b>Herramientas:</b> espátula <b>Dilución:</b> listo para usar <b>Rendimiento:</b> 1,4 kg/m <sup>2</sup> per mm de espesor <b>Color:</b> solo blanco	

tecniche	certificazioni	proprietà	tecnologie
 WATER BASED  TROWEL  READY TO USE			 flex 4





# coloranti

## coloranti universali ri



scheda  
tecnica



data  
sheet



ficha  
técnica



	interno		indoor		interiores
	Coloranti ad alta concentrazione di pigmenti organici ad altissimo potere colorante. Si ottengono tonalità intense con poco colorante, utilizzabili sia in prodotti all'acqua che in prodotti a solvente.		Dyes with high concentration of organic pigments with very high coloring power. Intense shades with little dye are obtained, usable both in water products and in solvent products.		Colorantes con alta concentración de pigmentos orgánicos con muy alto poder colorante. Se obtienen tonalidades intensas con poco colorante, que se puede utilizar tanto en agua productos como en productos a base de disolventes.
	<b>Idoneità prodotti:</b> pitture o smalti <b>Diluizione:</b> pronto all'uso <b>Quantità massima utilizzabile:</b> 6% in volume sul prodotto finito <b>Colore:</b> colori organici		<b>Idoneità products:</b> paint or enamel <b>Dilution:</b> ready to use <b>Quantità massima utilizzabile:</b> 6% in volume sul product finito <b>Color:</b> organic colors		<b>Idoneità productos:</b> pinturas o esmaltes <b>Dilución:</b> listo para usar <b>Cantidad máxima utilizable:</b> 6% en volumen sobre el producto terminado <b>color:</b> colores orgánicos

tecniche				certificazioni				proprietà				tecnologie			
WATER BASED	BRUSH	ROLLER	READY TO USE												

## coloranti universali re



scheda  
tecnica



data  
sheet



ficha  
técnica



	esterno		outdoor		exterior
	Coloranti ad alta concentrazione di pigmenti organici ed inorganici ad altissimo potere colorante. Si ottengono tonalità intense con poco colorante, utilizzabili sia in prodotti all'acqua che in prodotti a solvente.		Dyes with high concentration of organic and inorganic pigments with very high coloring power. Intense shades with little dye are obtained, usable both in water products and in solvent products.		Colorantes con alta concentración de pigmentos orgánicos con muy alto poder colorante. Se obtienen tonalidades intensas con poco colorante, que se puede utilizar tanto en agua productos como en productos a base de disolventes.
	<b>Idoneità prodotti:</b> pitture o smalti <b>Diluizione:</b> pronto all'uso <b>Quantità massima utilizzabile:</b> 6% in volume sul prodotto finito <b>Colore:</b> colori organici e inorganici		<b>Idoneità products:</b> paint or enamel <b>Dilution:</b> ready to use <b>Quantità massima utilizzabile:</b> 6% in volume sul product finito <b>Color:</b> organic and inorganic colors		<b>Idoneità productos:</b> pinturas o esmaltes <b>Dilución:</b> listo para usar <b>Cantidad máxima utilizable:</b> 6% en volumen sobre el producto terminado <b>color:</b> colores orgánicos e inorgánicos

tecniche				certificazioni				proprietà				tecnologie			
WATER BASED	BRUSH	ROLLER	READY TO USE												



# smalti

smalti ultrafini all'acqua

# prodotti

real matt  
real satin  
real gloss  
real tech



# h2o



## real matt

scheda  
tecnicadata  
sheetficha  
técnica

smalto opaco all'acqua	interno esterno	matt water-based enamel	indoor outdoor	esmalte mate al agua	interior exterior
<p>Smalto opaco all'acqua, di ottima pennellabilità, dilatazione, brillantezza. A base di resine acriliche, pigmenti idonei, additivi, inodore, non ingiallente, di ottima aderenza su supporti difficili conferendo ottima resistenza alle abrasioni agli agenti atmosferici. Specifico come finitura ultrafine per legno, metalli. La Classe TVOC A+ lo rende idoneo per ottemperare ai protocolli CAM, Leed Breeam. Per uso professionale.</p>		<p>Matt water-based enamel offering superb brushability, expansion and shine. Based on acrylic resins, suitable pigments and additives. Odourless, non yellowing, provides excellent adhesion on difficult substrates and superb resistance to abrasion and atmospheric agents. Specific as an ultra-fine topcoat for wood and metals. HACCP certified. Classified TVOC A+, it complies with Leed Breeam protocols. For professional use.</p>		<p>Esmalte mate al agua, de excelente facilidad de aplicación con brocha, dilatación, brillo. A base de resinas acrílicas, pigmentos adecuados, aditivos; inodoro, no amarillea, de excelente adherencia en soportes difíciles, proporciona una excelente resistencia a la abrasión y a los agentes atmosféricos. Especifico como acabado ultrafino para madera, metales. Certificado HACCP. La Clase TVOC A+ la hace idónea para cumplir con los protocolos Leed Breeam. Para uso profesional.</p>	
<p><b>Attrezzatura:</b> pennello, rullo, airless <b>Diluizione:</b> acqua - max 5% <b>Resa</b> (2 mani): 6,5-7 m<sup>2</sup>/l - Per confezione (5 l): 35 m<sup>2</sup> <b>Colore:</b> bianco e colorato</p>		<p><b>Equipment:</b> brush, roller, airless <b>Dilution:</b> water - max 5% <b>Coverage</b> (2 coats): 6,5-7 m<sup>2</sup>/l - Per packaging (5 l): 35 m<sup>2</sup> <b>Color:</b> white and colored</p>		<p><b>Herramientas:</b> brocha, rodillo, pistola pulverizadora <b>Dilución:</b> agua - max 5% <b>Rendimiento</b> (2 capas): 6,5-7 m<sup>2</sup>/l - Por envase (5 l): 35 m<sup>2</sup> <b>Color:</b> blanco y colorido</p>	

tecniche	certificazioni	proprietà	tecnologie

## real satin

scheda  
tecnicadata  
sheetficha  
técnica

smalto satinato all'acqua	interno esterno	satin water-based enamel	indoor outdoor	esmalte satinado al agua	interior exterior
<p>Smalto satinato all'acqua, di ottima pennellabilità, dilatazione, brillantezza. A base di resine acriliche, pigmenti idonei, additivi, inodore, non ingiallente, di ottima aderenza su supporti difficili conferendo ottima resistenza alle abrasioni agli agenti atmosferici. Specifico come finitura ultrafine per legno, metalli. La Classe TVOC A+ lo rende idoneo per ottemperare ai protocolli CAM, Leed Breeam. Per uso professionale.</p>		<p>Satin water-based enamel offering superb brushability, expansion and shine. Based on acrylic resins, suitable pigments and additives. Odourless, non yellowing, provides excellent adhesion on difficult substrates and superb resistance to abrasion and atmospheric agents. Specific as an ultra-fine topcoat for wood and metals. HACCP certified. Classified TVOC A+, it complies with Leed Breeam protocols. For professional use.</p>		<p>Esmalte satinado al agua, de excelente facilidad de aplicación con brocha, dilatación, brillo. A base de resinas acrílicas, pigmentos adecuados, aditivos; inodoro, no amarillea, de excelente adherencia en soportes difíciles, proporciona una excelente resistencia a la abrasión y a los agentes atmosféricos. Especifico como acabado ultrafino para madera, metales. Certificado HACCP. La Clase TVOC A+ la hace idónea para cumplir con los protocolos Leed Breeam. Para uso profesional.</p>	
<p><b>Attrezzatura:</b> pennello, rullo, airless <b>Diluizione:</b> acqua - max 5% <b>Resa</b> (2 mani): 6,5-7 m<sup>2</sup>/l - Per confezione (5 l): 35 m<sup>2</sup> <b>Colore:</b> bianco e colorato</p>		<p><b>Equipment:</b> brush, roller, airless <b>Dilution:</b> water - max 5% <b>Coverage</b> (2 coats): 6,5-7 m<sup>2</sup>/l - Per packaging (5 l): 35 m<sup>2</sup> <b>Color:</b> white and colored</p>		<p><b>Herramientas:</b> brocha, rodillo, pistola pulverizadora <b>Dilución:</b> agua - max 5% <b>Rendimiento</b> (2 capas): 6,5-7 m<sup>2</sup>/l - Por envase (5 l): 35 m<sup>2</sup> <b>Color:</b> blanco y colorido</p>	

tecniche	certificazioni	proprietà	tecnologie

## real gloss



scheda  
tecnica



data  
sheet



ficha  
técnica



smalto lucido all'acqua	interno esterno	glossy water-based enamel	indoor outdoor	esmalte brillante al agua	interior exterior
<p>Smalto lucido all'acqua, di ottima pennellabilità, dilatazione, brillantezza. A base di resine acriliche, pigmenti idonei, additivi, inodore, non ingiallente, di ottima aderenza su supporti difficili conferendo ottima resistenza alle abrasioni agli agenti atmosferici. Specifico come finitura ultrafina per legno, metalli. La Classe TVOC A+ lo rende idoneo per ottemperare ai protocolli CAM, Leed Breeam. Per uso professionale.</p>		<p>Glossy water-based enamel offering superb brushability, expansion and gloss. Based on acrylic resins, suitable pigments and additives. Odourless, non yellowing, provides excellent adhesion on difficult substrates and superb resistance to abrasion and atmospheric agents. Specific as an ultra-fine topcoat for wood and metals. HACCP certified. Classified TVOC A+, it complies with Leed Breeam protocols. For professional use.</p>		<p>Esmalte brillante al agua, de excelente facilidad de aplicación con brocha, dilatación, brillo. A base de resinas acrílicas, pigmentos adecuados, aditivos; inodoro, no amarillea, de excelente adherencia en soportes difíciles, proporciona una excelente resistencia a la abrasión y a los agentes atmosféricos. Especifico como acabado ultrafino para madera, metales. Certificado HACCP. La Clase TVOC A+ la hace idónea para cumplir con los protocolos Leed Breeam. Para uso profesional.</p>	
<p><b>Attrezzatura:</b> pennello, rullo, airless <b>Diluizione:</b> acqua - max 5% <b>Resa</b> (2 mani): 6,5-7 m<sup>2</sup>/l - Per confezione (5 l): 35 m<sup>2</sup> <b>Colore:</b> bianco e colorato</p>		<p><b>Equipment:</b> brush, roller, airless <b>Dilution:</b> water - max 5% <b>Coverage</b> (2 coats): 6,5-7 m<sup>2</sup>/l - Per packaging (5 l): 35 m<sup>2</sup> <b>Color:</b> white and colored</p>		<p><b>Herramientas:</b> brocha, rodillo, pistola pulverizadora <b>Dilución:</b> agua - max 5% <b>Rendimiento</b> (2 capas): 6,5-7 m<sup>2</sup>/l - Por envase (5 l): 35 m<sup>2</sup> <b>Color:</b> blanco y colorido</p>	

tecniche	certificazioni	proprietà	tecnologie

## real tech



scheda  
tecnica



data  
sheet



ficha  
técnica



finitura all'acqua per ceramica e clinker	interno esterno	water-based topcoat for ceramics and clinker	indoor outdoor	acabado al agua para cerámica y clinker	interior exterior
<p>Smalto all'acqua a base di resine acriliche, cariche e additivi in dispersione acquosa dall'aspetto satinato. Permette di modificare esteticamente le finiture ceramiche esistenti come bagni e cucine. Real tech si applica direttamente su piastrelle o clinker senza ausilio di primer, pronto uso. Destinato a pareti verticali e orizzontali di piccole dimensioni e se moderatamente pedonabili. La Classe TVOC A+ lo rende idoneo per ottemperare ai protocolli CAM, Leed Breeam. Per uso professionale.</p>		<p>Water-based enamel with acrylic resins, extenders and additives dispersed in water. Satin finish. Makes it possible to change the look of existing ceramic bathroom and kitchen tiles. Real tech comes ready to use and is applied directly on the tiles or clinker. Does not require a primer. Intended for use on small vertical and horizontal surfaces and those subject to moderate foot traffic. Classified TVOC A+, it complies with Leed Breeam protocols. For professional use.</p>		<p>Esmalte al agua a base de resinas acrílicas, cargas y aditivos en dispersión acuosa de aspecto satinado. Permite modificar estéticamente los acabados cerámicos ya existentes de baños y cocinas. Real tech se aplica directamente sobre baldosas o clinker sin recurrir a imprimación, listo para usar. Destinado a paredes verticales y horizontales de pequeño tamaño, sujetas a un tránsito peatonal moderado. La Clase TVOC A+ la hace idónea para cumplir con los protocolos Leed Breeam. Para uso profesional.</p>	
<p><b>Attrezzatura:</b> pennello, rullo, airless <b>Diluizione:</b> acqua - max 5% <b>Resa</b> (2 mani): 6,5-7 m<sup>2</sup>/l - Per confezione (5 l): 40 m<sup>2</sup> <b>Colore:</b> bianco e colorato</p>		<p><b>Equipment:</b> brush, roller, airless <b>Dilution:</b> water - max 5% <b>Coverage</b> (2 coats): 6,5-7 m<sup>2</sup>/l - Per packaging (5 l): 40 m<sup>2</sup> <b>Color:</b> white and colored</p>		<p><b>Herramientas:</b> brocha, rodillo, pistola pulverizadora <b>Dilución:</b> agua - max 5% <b>Rendimiento</b> (2 capas): 6,5-7 m<sup>2</sup>/l - Por envase (5 l): 40 m<sup>2</sup> <b>Color:</b> blanco y colorido</p>	

tecniche	certificazioni	proprietà	tecnologie



# smalti

smalti alte prestazioni



# prodotti

crystal

crystal sx

aderlac hq

micafer



## crystal

scheda  
tecnicadata  
sheetficha  
técnica

smalto alchidico uretano lucido	interno esterno	shiny enamel containing alkyd resins with urethane	indoor outdoor	esmalte alquídico uretánico brillante	interior exterior
Smalto alchidico uretanico lucido supercoprente extrafine. Possiede caratteristiche eccezionali di adesione, pienezza, durezza superficiale, resistenza agli agenti atmosferici e alla luce. Ideale per proteggere e decorare supporti metallici e legno in atmosfera marina ed industriale. Dotato di eccellente pennellabilità, dilatazione ed elevata resistenza alle colature. Per uso professionale.		Shiny alkyd enamel with urethane, extra-fine, offering superb coverage. Extraordinary adhesion, fullness, surface hardness, resistance to the weather and light. Ideal for protecting and decorating metal and wood substrates in marine and industrial atmospheres. Excellent brushability, expansion and high resistance to dripping. For professional use.		Esmalte alquídico brillante supercubriente extrafino. Posee características excepcionales de adhesión, cuerpo, dureza superficial, resistencia a los agentes atmosféricos y a la luz. Ideal para proteger y decorar soportes metálicos y madera en atmósferas marinas e industriales. Dotado de excelente facilidad de aplicación con brocha, dilatación y alta resistencia a la formación de goterones. Para uso profesional.	
<b>Attrezzatura:</b> pennello, rullo, airless <b>Diluizione:</b> pronto all'uso <b>Resa</b> (2 mani): 6,5-7 m <sup>2</sup> /l - Per confezione (10 l): 65 m <sup>2</sup> <b>Colore:</b> bianco e colorato		<b>Equipment:</b> brush, roller, airless <b>Dilution:</b> ready to use <b>Coverage</b> (2 coats): 6,5-7 m <sup>2</sup> /l - Per packaging (10 l): 65 m <sup>2</sup> <b>Color:</b> white and colored		<b>Herramientas:</b> brocha, rodillo, pistola pulverizadora <b>Dilución:</b> listo para usar <b>Rendimiento</b> (2 capas): 6,5-7 m <sup>2</sup> /l - Por envase (10 l): 65 m <sup>2</sup> <b>Color:</b> blanco y colorido	

tecniche	certificazioni	proprietà	tecnologie

## crystal sx

scheda  
tecnicadata  
sheetficha  
técnica

smalto alchidico uretano opaco	interno esterno	matt enamel containing alkyd resins with urethane	indoor outdoor	esmalte alquídico uretánico mate	interior exterior
Smalto alchidico uretanico opaco supercoprente extrafine. Possiede caratteristiche eccezionali di adesione, pienezza, durezza superficiale, resistenza agli agenti atmosferici e alla luce. Ideale per proteggere e decorare supporti metallici e legno in atmosfera marina ed industriale. Dotato di eccellente pennellabilità, dilatazione ed elevata resistenza alle colature. Per uso professionale.		Matt alkyd enamel with urethane, extra-fine, offering superb coverage. Extraordinary adhesion, fullness, surface hardness, resistance to the weather and light. Ideal for protecting and decorating metal and wood substrates in marine and industrial atmospheres. Excellent brushability, expansion and high resistance to dripping. For professional use.		Esmalte alquídico mate supercubriente extrafino. Posee características excepcionales de adhesión, cuerpo, dureza superficial, resistencia a los agentes atmosféricos y a la luz. Ideal para proteger y decorar soportes metálicos y madera en atmósferas marinas e industriales. Dotado de excelente facilidad de aplicación con brocha, dilatación y alta resistencia a la formación de goterones. Para uso profesional.	
<b>Attrezzatura:</b> pennello, rullo, airless <b>Diluizione:</b> pronto all'uso <b>Resa</b> (2 mani): 6,5-7 m <sup>2</sup> /l - Per confezione (10 l): 65 m <sup>2</sup> <b>Colore:</b> bianco e colorato		<b>Equipment:</b> brush, roller, airless <b>Dilution:</b> ready to use <b>Coverage</b> (2 coats): 6,5-7 m <sup>2</sup> /l - Per packaging (10 l): 65 m <sup>2</sup> <b>Color:</b> white and colored		<b>Herramientas:</b> brocha, rodillo, pistola pulverizadora <b>Dilución:</b> listo para usar <b>Rendimiento</b> (2 capas): 6,5-7 m <sup>2</sup> /l - Por envase (10 l): 65 m <sup>2</sup> <b>Color:</b> blanco y colorido	

tecniche	certificazioni	proprietà	tecnologie

## aderlac hq



scheda  
tecnica



data  
sheet



ficha  
técnica



smalto semilucido per lamiere zincate	<b>esterno</b>	semi-gloss enamel for galvanised sheet	<b>outdoor</b>	esmalte semibrillante para chapas galvanizadas	<b>exterior</b>
Smalto semilucido a base di resina acrilica per applicazione diretta su lamiere zincate altamente resistente agli agenti atmosferici ed alle atmosfere industriali, mantiene inalterate nel tempo le caratteristiche di impermeabilità, elasticità ed aderenza. Per uso professionale.		Semi-gloss, acrylic resin-based enamel. Offers superb resistance to the weather and industrial atmospheres, maintaining its impermeability, elasticity and adherence unaltered in time. Direct application on galvanised sheets. For professional use.		Esmalte semibrillante a base de resina acrílica altamente resistente a los agentes atmosféricos y a las atmósferas industriales, mantiene inalteradas con el paso del tiempo las características de impermeabilidad, elasticidad y adherencia. Aplicación directa sobre chapas galvanizadas. Para uso profesional.	
<b>Attrezzatura:</b> pennello, rullo, airless <b>Diluizione:</b> Diluente Sintetico - a pennello 3%, a airless 5% <b>Resa (2 mani):</b> 6 m <sup>2</sup> /l - Per confezione (10 l): 60 m <sup>2</sup> <b>Colore:</b> bianco e colorato		<b>Equipment:</b> brush, roller, airless <b>Dilution:</b> Diluente Sintetico - brush 3%, a airless 5% <b>Coverage (2 coats):</b> 6 m <sup>2</sup> /l - Per packaging (10 l): 60 m <sup>2</sup> <b>Color:</b> white and colored		<b>Herramientas:</b> brocha, rodillo, pistola pulverizadora <b>Dilución:</b> Diluente Sintetico - a brocha 3%, a pistola pulverizadora 5% <b>Rendimiento (2 capas):</b> 6 m <sup>2</sup> /l - Por envase (10 l): 60 m <sup>2</sup> <b>Color:</b> blanco y colorido	

<b>tecniche</b>	<b>certificazioni</b>	<b>proprietà</b>	<b>tecnologie</b>

## micafer



scheda  
tecnica



data  
sheet



ficha  
técnica



smalto alchidico ferromicaceo	<b>esterno</b>	Ferromicaceous alkyd enamel	<b>outdoor</b>	esmalte alquídico ferromicáceo	<b>exterior</b>
Smalto alchidico con pigmenti a struttura lamellare con effetto ferromicaceo. Possiede ottime proprietà anticorrosive, elevata resistenza all'esterno, ottimo potere coprente e riempitivo, facile pennellabilità e distensione. La struttura lamellare del pigmento crea un'efficace barriera all'umidità ed ai raggi ultravioletti proteggendo il supporto dalla corrosione. Per uso professionale.		Alkyd enamel with lamellar structure pigments that produce a micaceous iron oxide effect. Excellent anticorrosive properties, high outdoor resistance, excellent coverage and superb filling. Good brushability and spreadability. The lamellar pigment structure creates an effective barrier to moisture and ultraviolet radiation, protecting the substrate from corrosion and chalking. For outdoor use. For professional use.		Esmalte alquídico con pigmentos de estructura laminar con efecto ferromicáceo. Posee excelentes propiedades anticorrosión, gran resistencia a la intemperie, óptima capacidad cubriente y de relleno, fácil aplicación y distensión con brocha. La estructura laminar del pigmento crea una eficaz barrera contra la humedad y los rayos ultravioleta, protegiendo el soporte de la corrosión y de la desintegración pulverulenta. Para uso profesional.	
<b>Attrezzatura:</b> pennello, airless <b>Diluizione:</b> Diluente Sintetico - a pennello 3%, a airless 5% <b>Resa (2 mani):</b> 5 m <sup>2</sup> /l - Per confezione (10 l): 50 m <sup>2</sup> <b>Colore:</b> bianco e colorato		<b>Equipment:</b> brush, airless <b>Dilution:</b> Diluente Sintetico - a brush 3%, a airless 5% <b>Coverage (2 coats):</b> 5 m <sup>2</sup> /l - Per packaging (10 l): 50 m <sup>2</sup> <b>Color:</b> white and colored		<b>Herramientas:</b> brocha, pistola pulverizadora <b>Dilución:</b> Diluente Sintetico - a brocha 3%, a pistola pulverizadora 5% <b>Rendimiento (2 capas):</b> 5 m <sup>2</sup> /l - Por envase (10 l): 50 m <sup>2</sup> <b>Color:</b> blanco y colorido	

<b>tecniche</b>	<b>certificazioni</b>	<b>proprietà</b>	<b>tecnologie</b>





# antirug fondi

# prodotti

fondo per legno

fondo H<sub>2</sub>O per legno

primex hq

rusty

minio oleofenolico



# ggini e

## fondo per legno

scheda  
tecnicadata  
sheetficha  
técnica

fondo riempitivo per legno a base solvente	<b>interno</b>	solvent-based wood filler base coat	<b>indoor</b>	fondo de relleno para madera con base disolvente	<b>interiores</b>
Fondo isolante ed uniformante a base solvente per elementi in legno per successive applicazioni di finiture coprenti. Possiede eccezionale copertura e punto di bianco. Maschera le rugosità del legno. Per uso professionale.		Solvent-based insulating and levelling base coat to prepare wood items for subsequent application of opaque topcoats. Provides exceptional coverage and whiteness. Masks the roughness of wood. For professional use		Fondo aislante y uniformante con base disolvente para elementos de madera para sucesivas aplicaciones de acabados cubrientes. Posee una excepcional capacidad cubriente y punto de blanco. Enmascara las rugosidades de la madera. Para uso profesional.	
<b>Attrezzatura:</b> pennello, rullo, airless <b>Diluizione:</b> Diluente Sintetico - max 5% <b>Resa</b> (1 mano): 10-12 m <sup>2</sup> /l - Per confezione (10 l): 120 m <sup>2</sup> <b>Colore:</b> solo bianco		<b>Equipment:</b> brush, roller, airless <b>Dilution:</b> Diluente Sintetico - max 5% <b>Coverage</b> (1 coat): 10-12 m <sup>2</sup> /l - Per packaging (10 l): 120 m <sup>2</sup> <b>Color:</b> only white		<b>Herramientas:</b> brocha, rodillo, pistola pulverizadora <b>Dilución:</b> Diluyente Sintetico - max 5% <b>Rendimiento (1 capa):</b> 10-12 m <sup>2</sup> /l - Por envase (10 l): 120 m <sup>2</sup> <b>Color:</b> solo blanco	

tecniche				certificazioni				proprietà				tecnologie			

fondo H<sub>2</sub>O per legnoscheda  
tecnicadata  
sheetficha  
técnica

fondo riempitivo per legno a base acqua	<b>interno esterno</b>	water-based wood filler base coat	<b>indoor outdoor</b>	fondo de relleno para madera con base de agua	<b>interior exterior</b>
Fondo isolante ed uniformante a base acqua per elementi in legno per successive applicazioni di finiture coprenti a base acqua. Possiede eccezionale copertura e punto di bianco. Maschera le rugosità del legno. Per uso professionale.		Water-based insulating and levelling base coat to prepare wood items for subsequent application of water-based opaque topcoats. Provides exceptional coverage and whiteness. Masks the roughness of wood. For professional use		Fondo aislante y uniformante con base de agua para elementos de madera para sucesivas aplicaciones de acabados cubrientes al agua. Posee una excepcional capacidad cubriente y punto de blanco. Enmascara las rugosidades de la madera. Para uso profesional.	
<b>Attrezzatura:</b> pennello, rullo, airless <b>Diluizione:</b> Acqua - pennello e rullo 5-7% = 50 ml ogni litro di prodotto, A spruzzo 10-12% = 100-120ml/l <b>Resa:</b> 9-10 m <sup>2</sup> /l in funzione dell'assorbimento supporto <b>Colore:</b> solo bianco		<b>Equipment:</b> brush, roller, airless <b>Dilution:</b> Water - brush and roller 5-7% = 50 ml per liter of product By spray 10-12% = 100-120ml / l <b>Coverage:</b> 9-10 m <sup>2</sup> /l depending on the support absorption <b>Color:</b> only white		<b>Herramientas:</b> brocha, rodillo, pistola pulverizadora <b>Dilución:</b> Agua - brocha y rodillo 5-7% = 50 ml por litro de producto, Por pulverización 10-12% = 100-120ml/l <b>Rendimiento :</b> 9-10C m <sup>2</sup> /l dependiendo de la absorción del soporte <b>Color:</b> solo blanco	

tecniche				certificazioni				proprietà				tecnologie			

## primex hq



scheda  
tecnica



data  
sheet



ficha  
técnica

fondo pigmentato ad alta adesione	<b>interno esterno</b>	high adhesion pigmented topcoat	<b>indoor outdoor</b>	fondo pigmentado de gran capacidad de adhesión	<b>interior exterior</b>
Fondo monocomponente universale pigmentato, a base di resine acriliche in dispersione acquosa. Caratterizzato da elevato potere di adesione su supporti difficili e da ottima proprietà antiruggine. Può essere applicato su: lamiera zincata, plexiglass, pvc, alluminio e metalli ferrosi e non ferrosi. Per uso professionale.		One-pack, pigmented base coat with acrylic resin-based dispersed in water. Offers high adhesion power on difficult substrates and excellent rustproofing properties. Can be applied on: galvanised sheet metal, plexiglass, PVC, aluminium and both ferrous and non-ferrous metals. For professional use.		Fondo monocomponente universal pigmentado a base de resinas acrílicas en dispersión acuosa. Caracterizado por una gran capacidad de adhesión sobre soportes difíciles y por excelentes propiedades antióxido. Puede aplicarse sobre: chapa galvanizada, plexiglás, pvc, aluminio y metales ferrosos/no ferrosos. Para uso profesional.	
<b>Attrezzatura:</b> pennello, rullo, airless <b>Diluizione:</b> Acqua - max 10% <b>Resa</b> (1 mano): 8-10 m <sup>2</sup> /l - Per confezione (2,5 l): 25 m <sup>2</sup> <b>Colore:</b> bianco e colorato		<b>Equipment:</b> brush, roller, airless <b>Dilution:</b> water - max 10% <b>Coverage</b> (1 coat): 8-10 m <sup>2</sup> /l - Per packaging (2,5 l): 25 m <sup>2</sup> <b>Color:</b> white and colored		<b>Herramientas:</b> brocha, rodillo, pistola pulverizadora <b>Dilución:</b> agua - max 10% <b>Rendimiento</b> (1 capa): 8-10 m <sup>2</sup> /l - Por envase (2,5 l): 25 m <sup>2</sup> <b>Color:</b> blanco y colorido	

<b>tecniche</b>	<b>certificazioni</b>	<b>proprietà</b>	<b>tecnologie</b>
 WATER BASED  BRUSH  ROLLER  AIRLESS			

## rusty



scheda  
tecnica



data  
sheet



ficha  
técnica

fondo antiruggine sintetico opaco	<b>interno esterno</b>	mat synthetic rust proofing base coat	<b>indoor outdoor</b>	fondo antióxido sintético mate	<b>interior exterior</b>
Fondo antiruggine sintetico opaco, monocomponente ad alte prestazioni, con elevato potere di adesione e protezione. Dotato di ottima adesione su: acciaio, acciaio zincato sia a caldo che a freddo, vecchie verniciature opportunamente carteggiate. Ideale come fondo per successive verniciature con Crystal. Per uso professionale.		One-pack, high-performance, synthetic rust proofing base coat with high adhesion and protection power. Has excellent adhesion on: steel, hot and cold galvanised steel, old paints suitably sanded. Matt finish. Ideal as a base for subsequent varnishing with Crystal. For professional use.		Fondo antióxido sintético mate, monocomponente de altas prestaciones, con gran poder adhesivo y protección. Dotado de excelente adhesión sobre: acero, acero galvanizado, tanto en caliente como en frío, pinturas viejas debidamente lijadas. Para uso profesional.	
<b>Attrezzatura:</b> pennello, rullo, airless <b>Diluizione:</b> Diluente Sintetico - max 5% (airless 10%) <b>Resa</b> (1 mano): 8-10 m <sup>2</sup> /l - Per confezione (10 l): 100 m <sup>2</sup> <b>Colore:</b> bianco e colorato		<b>Equipment:</b> brush, roller, airless <b>Dilution:</b> Diluente Sintetico - max 5% (airless 10%) <b>Coverage</b> (1 coat): 8-10 m <sup>2</sup> /l - Per packaging (10 l): 100 m <sup>2</sup> <b>Color:</b> white and colored		<b>Herramientas:</b> brocha, rodillo, pistola pulverizadora <b>Dilución:</b> Diluente Sintetico - max 5% (pistola pulverizadora 10%) <b>Rendimiento</b> (1 capa): 8-10 m <sup>2</sup> /l - Por envase (10 l): 100 m <sup>2</sup> <b>Color:</b> blanco y colorido	

<b>tecniche</b>	<b>certificazioni</b>	<b>proprietà</b>	<b>tecnologie</b>
 SOLVENT BASED  BRUSH  ROLLER  AIRLESS		 <b>mat</b> BRILLIANCE	

## minio oleofenolico



scheda  
tecnica







data  
sheet



ficha  
técnica

fondo antiruggine oleofenolico	<b>esterno</b>	oleophenolic rustproofing base coat	<b>outdoor</b>	fondo antióxido oleofenólico	<b>exterior</b>
Fondo antiruggine a base di resine oleofenoliche e cariche che conferiscono ottime caratteristiche antiruggine. Per esterno. Per uso professionale.		Rust proofing base coat with oleophenolic resins and fillers to provide excellent rust proofing properties. For professional use.		Fondo antióxido a base de resinas oleofenólicas y cargas que proporcionan excelentes características antióxido. Para uso profesional.	
<b>Attrezzatura:</b> pennello, rullo, airless <b>Diluizione:</b> Diluente Sintetico - max 5% <b>Resa</b> (1 mano): 8-10 m <sup>2</sup> /l - Per confezione (2,5 l): 25 m <sup>2</sup> <b>Colore:</b> arancio		<b>Equipment:</b> brush, roller, airless <b>Dilution:</b> Diluente Sintetico - max 5% <b>Coverage</b> (1 coat): 8-10 m <sup>2</sup> /l - Per packaging (2,5 l): 25 m <sup>2</sup> <b>Color:</b> orange		<b>Herramientas:</b> brocha, rodillo, pistola pulverizadora <b>Dilución:</b> Diluente Sintetico - max 5% <b>Rendimiento</b> (1 capa): 8-10 m <sup>2</sup> /l - Por envase (2,5 l): 25 m <sup>2</sup> <b>Color:</b> naranja	

<b>tecniche</b>	<b>certificazioni</b>	<b>proprietà</b>	<b>tecnologie</b>
 SOLVENT BASED  BRUSH  ROLLER  AIRLESS		 <b>mat</b> BRILLIANCE	



Graffiti

protetto

# prodotti

silcal

silcal w

silacril

antigraffiti w

acrilux

algasol



# graffiti



## silcal



scheda  
tecnica



data  
sheet



ficha  
técnica



protettivo silossanico non filmogeno	<b>esterno</b>	non film-forming, siloxane-based pro- tective coating	<b>outdoor</b>	protector siloxánico no filmógeno	<b>exterior</b>
<p>Protettivo trasparente a base di polisilossani oligomeri sciolti in solvente, formulata per dare al supporto idrorepellenza superficiale e in profondità, possiede un elevato potere penetrante e traspirante e polimerizza in profondità. Non è filmogeno, non modifica assolutamente l'estetica del manufatto. Per uso professionale.</p>		<p>Transparent protective coating based on polysiloxane oligomers dissolved in solvent, formulated to make the substrate water repellent both on the surface and in depth. It has high penetrating power, is breathable and polymerizes in depth. It is non film-forming and does not alter the appearance of the product treated at all. For professional use.</p>		<p>Protector transparente a base de polisiloxanos oligómeros disueltos en disolvente, formulado para dar al soporte propiedades hidro-repelentes en superficie y en profundidad, posee un alto poder penetrante y traspirante y polimeriza en profundidad. No es filmógeno, no modifica lo más mínimo la estética de las manufacturas. Para uso profesional.</p>	
<p><b>Attrezzatura:</b> pennello, rullo, airless <b>Diluizione:</b> pronto all'uso <b>Resa</b> (1 mano): 8-10 m<sup>2</sup>/l - Per confezione (25 l): 250 m<sup>2</sup> <b>Colore:</b> incolore</p>		<p><b>Equipment:</b> brush, roller, airless <b>Dilution:</b> ready to use <b>Coverage</b> (1 coat): 8-10 m<sup>2</sup>/l - Per packaging (25 l): 250 m<sup>2</sup> <b>Color:</b> colourless</p>		<p><b>Herramientas:</b> brocha, rodillo, pistola pulverizadora <b>Dilución:</b> listo para usar <b>Rendimiento</b> (1 capa): 8-10 m<sup>2</sup>/l - Por envase (25 l): 250 m<sup>2</sup> <b>Color:</b> incoloro</p>	

tecniche	certificazioni	proprietà	tecnologie
SOLVENT BASED BRUSH ROLLER AIRLESS READY TO USE			

## silcal w



scheda  
tecnica



data  
sheet



ficha  
técnica



resina monocomponente a iniezione	<b>interno esterno</b>	one-pack injection resin	<b>indoor outdoor</b>	resina monocomponente de inyección	<b>interior exterior</b>
<p>Microemulsione a base di silani e silossani monocomponente a base acqua pronto uso, contro la risalita capillare di umidità nelle muraure. Reagisce con l'umidità del supporto formando una pellicola idrorepellente che intasando le porosità ne impedisce l'assorbimento eliminando così la risalita dell'acqua dal terreno o dalle fondamenta. Per uso professionale.</p>		<p>One-pack, ready-to-use, water-based micro-emulsion with silanes and siloxanes to treat capillary rising damp in masonry. Reacts with the damp in the substrate, forming a highly waterproof film that plugs the pores, thus preventing any absorption and rising of water from the foundations or underlying ground. For professional use.</p>		<p>Microemulsión a base de silanos y siloxanos, monocomponente con base de agua listo para usar, contra la expansión capilar de la humedad en las paredes. Reacciona con la humedad del soporte formando una película hidro-repelente que, obturando las porosidades, impide la absorción y elimina completamente la subida del agua desde el terreno o desde los cimientos. Para uso profesional.</p>	
<p><b>Attrezzatura:</b> Pompa volumetrica a bassa pressione <b>Diluizione:</b> pronto all'uso <b>Resa:</b> in funzione dell'assorbimento della muratura, indicativamente 7 l/m<sup>2</sup> per muratura da 40 cm <b>Colore:</b> incolore</p>		<p><b>Equipment:</b> Low pressure volumetric pump <b>Dilution:</b> ready to use <b>Coverage:</b> as a function of the absorption of the masonry, approximately 7 l/m<sup>2</sup> for 40 cm masonry <b>Color:</b> colourless</p>		<p><b>Herramientas:</b> Bomba volumétrica de baja presión <b>Dilución:</b> listo para usar <b>Rendimiento:</b> Según la absorción de la mampostería. Aproximadamente 7 litros / m para mampostería de 40 cm <b>Color:</b> incoloro</p>	

tecniche	certificazioni	proprietà	tecnologie
WATER BASED BRUSH ROLLER AIRLESS READY TO USE			

## silacril



scheda  
tecnica



data  
sheet



ficha  
técnica



protettivo silossanico filmogeno	esterno	film-forming siloxane protective coating	outdoor	protector siloxánico filmógeno	exterior
<p>Protettivo trasparente filmogeno, traspirante, al solvente a base di resine acriliche modificate con polisilossani oligomeri. Formulata per dare al supporto notevole idrorepellenza, anche in profondità, contemporaneamente ad una discreta azione barriera alla penetrazione dei gas a reazione acida contenuti nell'atmosfera. Ha un effetto perlante durevole nel tempo. Per uso professionale.</p>		<p>Breathable, film-forming, transparent protective coating made with acrylic resin-based solvent modified with oligomer polysiloxanes. Formulated to make the substrate extremely water repellent, even in-depth, while offering, at the same time, a fair barrier against the penetration of acid reaction gases contained in the atmosphere. Long-lasting pearl-finish effect. For outdoor use. For professional use.</p>		<p>Protector transparente filmógeno, transpirante, con disolvente a base de resinas acrílicas modificadas con polisiloxanos oligómeros. Formulado para dar al soporte una notable capacidad hidro-repelente, incluso en profundidad, y al mismo tiempo una discreta acción de barrera contra la penetración de los gases de reacción ácida contenidos en la atmósfera. Tiene un efecto perlado duradero. Para uso profesional.</p>	
<p><b>Attrezzatura:</b> pennello, rullo, airless <b>Diluizione:</b> pronto all'uso <b>Resa</b> (1 mano): 8-10 m<sup>2</sup>/l - Per confezione (25 l): 250 m<sup>2</sup> <b>Colore:</b> incolore</p>		<p><b>Equipment:</b> brush, roller, airless <b>Dilution:</b> ready to use <b>Coverage</b> (1 coat): 8-10 m<sup>2</sup>/l - Per packaging (25 l): 250 m<sup>2</sup> <b>Color:</b> colourless</p>		<p><b>Herramientas:</b> brocha, rodillo, pistola pulverizadora <b>Dilución:</b> listo para usar <b>Rendimiento</b> (1 capa): 8-10 m<sup>2</sup>/l - Por envase (25 l): 250 m<sup>2</sup> <b>Color:</b> incoloro</p>	

tecniche	certificazioni	proprietà	tecnologie
SOLVENT BASED BRUSH ROLLER AIRLESS READY TO USE		BREATHABLE	

## antigraffiti w



scheda  
tecnica



data  
sheet



ficha  
técnica



vernice all'acqua antigraffiti trasparente	esterno	transparent, anti-graffiti varnish	outdoor	pintura al agua antigraffiti transparente	exterior
<p>Vernice bicomponente appositamente formulata per rendere estremamente difficile qualsiasi tipo di scritta o graffito sui supporti precedentemente trattati. A base di resina poliesteri ossidrilata ed addotti isocianici con additivi polisilossanici. Non ingiallente, ottima resistenza agli aggressivi chimici. Eccellente aderenza su supporti difficili. Per uso professionale.</p>		<p>Two-pack varnish specially formulated to make it extremely difficult to write or draw any form of graffiti on the treated substrates. Based on hydroxylated polyester resin and isocyanate adducts with polysiloxane additives. Non-yellowing, highly resistant to chemicals. Excellent adhesion on difficult substrates. For professional use.</p>		<p>Barniz bicomponente expresamente formulado para hacer extremadamente difícil cualquier tipo de pintada o grafiti sobre los soportes previamente tratados. A base de resina poliéster oxidrilada y aductos isocianicos con aditivos polisiloxánicos. No amarillea, excelente resistencia a los agentes químicos agresivos. Excelente adherencia en soportes difíciles. Para uso profesional.</p>	
<p><b>Attrezzatura:</b> pennello, rullo, airless <b>Diluizione:</b> pronto all'uso <b>Resa</b> (2 mani): 5-7 m<sup>2</sup>/l - Per confezione (3 l + 0,24 l): 15 m<sup>2</sup> <b>Colore:</b> incolore</p>		<p><b>Equipment:</b> brush, roller, airless <b>Dilution:</b> ready to use <b>Coverage</b> (2 coats): 5-7 m<sup>2</sup>/l - Per packaging (3 l + 0,24 l): 15 m<sup>2</sup> <b>Color:</b> colourless</p>		<p><b>Herramientas:</b> brocha, rodillo, pistola pulverizadora <b>Dilución:</b> listo para usar <b>Rendimiento</b> (2 capas): 5-7 m<sup>2</sup>/l - Por envase (3 l + 0,24 l): 15 m<sup>2</sup> <b>Color:</b> incoloro</p>	

tecniche	certificazioni	proprietà	tecnologie
WATER BASED BRUSH ROLLER AIRLESS READY TO USE			RESISTANCE 4

## acrilux



scheda  
tecnica



data  
sheet



ficha  
técnica



protettivo trasparente lucido per rivestimenti e pitture	<b>esterno</b>	glossy transparent protective product for coatings and paints	<b>outdoor</b>	protector trasparente brillante para revestimientos y pinturas	<b>exterior</b>
Protettivo trasparente a base di particolari resine emulsionate in veicolo acquoso, da applicare come strato di finitura trasparente. Conferisce basso assorbimento e aspetto lucido. Idoneo come protettivo per Rivestimenti colorati e Paint HT. Per uso professionale.		Transparent protective product with special resins in a water-based emulsion, to be applied as a transparent topcoat. Provides low absorption and glossy appearance. Suitable as protective product for coloured coatings and Paint HT. For outdoor use. For professional use.		Protector transparente a base de resinas especiales emulsionadas en vehículo acuoso, para su aplicación como capa de acabado transparente. Proporciona baja absorción y aspecto brillante. Idóneo como protector para revestimientos de color y Paint HT. Para uso profesional.	
<b>Attrezzatura:</b> pennello, rullo <b>Diluizione:</b> pronto all'uso <b>Resa (1 mano):</b> come lucidante 8-10 m <sup>2</sup> /l - Per confezione (25 l): 250 m <sup>2</sup> <b>Colore:</b> incolore		<b>Equipment:</b> brush, roller <b>Dilution:</b> ready to use <b>Coverage (1 coat):</b> as a polishing 8-10 m <sup>2</sup> /l - Per packaging (25 l): 250 m <sup>2</sup> <b>Color:</b> colourless		<b>Herramientas:</b> brocha, rodillo <b>Dilución:</b> listo para usar <b>Rendimiento (1 capa):</b> 8-10 m <sup>2</sup> /l - Por envase (25 l): 250 m <sup>2</sup> <b>Color:</b> incoloro	

<b>tecniche</b>	<b>certificazioni</b>	<b>proprietà</b>	<b>tecnologie</b>
WATER BASED BRUSH ROLLER READY TO USE		gloss BRILLIANCE	resistance 3

## algasol



scheda  
tecnica



data  
sheet



ficha  
técnica



soluzione battericida	<b>esterno</b>	bactericidal solution	<b>outdoor</b>	solución bactericida	<b>exterior</b>
Soluzione battericida da aggiungere a Paint HT e rivestimenti plastici continui, specifica per prevenire la proliferazione e conseguente annerimento dovuto alla presenza di alghe e muffe in ambienti esterni. Per uso professionale.		Bactericidal solution to be added to Paint HT and continuous plastic coatings, specifically designed to prevent the proliferation of algae, mould and mildew, and the blackening they produce in outdoor environments. For outdoor use. For professional use.		Solución bactericida para añadir a Paint HT y revestimientos plásticos continuos, específica para prevenir la proliferación y el consiguiente ennegrecimiento debido a la presencia de algas y mohos en ambientes externos. Para uso profesional.	
<b>Modalità di utilizzo:</b> aggiungere il prodotto in ragione di 1 l ogni 14 l di idropittura a pennello (0,500 l ogni 25 kg di Rivestimenti Plastici Continui). La diluizione dei prodotti deve tenere conto della quantità di Algasol già aggiunta <b>Colore:</b> incolore		<b>How to use:</b> Add Algasol in the following doses: - 1 litre for every 14 litres of water-based paint for brush applications (0.5 litres for every 25 kg of continuous plastic coating). Product dilution must take into account the quantity of Algasol already added <b>Color:</b> colourless		<b>Como se usa:</b> 1 litro cada 14 litros de pintura al agua en brocha 0,5 litros cada 25 kg de revestimientos plásticos continuos. <b>color:</b> incolore	







**prodotti  
speciali**

# prodotti

capsulit

amianfix

muralpac liscio

bitum flex

detergente ac

grafinet

stonet

zincobrill

spartitraffico

sverniciatore n11

bio past

catalizzatore z8

armatex micro

ti  
li



## capsulit

scheda  
tecnicadata  
sheetficha  
técnica

pittura per incapsulamento amianto certificata	esterno	certified paint for asbestos encapsulation	outdoor	pintura certificada para encapsular amianto	exterior
Pittura impermeabilizzante a base di resine acriliche, dotata di un'alta resistenza allo sporco, appositamente formulata per l'incapsulamento delle lastre di cemento amianto. Non permette il passaggio e la dispersione nell'atmosfera delle particelle di amianto contenute nel supporto. Per uso professionale.		Acrylic resin-based waterproofing paint with high resistance to dirt. Specially formulated to encapsulate asbestos cement sheets. Prevents the particles of asbestos contained in the substrate from being dispersed in the atmosphere. For professional use.		Pintura impermeabilizante a base de resinas acrílicas, dotada de alta resistencia a la suciedad, expresamente formulada para el encapsulado de las placas de amianto cemento. No permite el paso ni la dispersión en la atmósfera de las partículas de amianto contenidas en el soporte. Para uso profesional.	
<b>Attrezzatura:</b> pennello, rullo, airless <b>Diluizione:</b> acqua - max 5% <b>Resa (3 mani):</b> 1,6 m <sup>2</sup> /l - Per confezione (14 l): 22,4 m <sup>2</sup> <b>Colore:</b> bianco e colorato		<b>Equipment:</b> brush, roller, airless <b>Dilution:</b> water - max 5% <b>Coverage (3 coats):</b> 1,6 m <sup>2</sup> /l - Per packaging (14 l): 22,4 m <sup>2</sup> <b>Color:</b> white and colored		<b>Herramientas:</b> brocha, rodillo, pistola pulverizadora <b>Dilución:</b> agua - max 5% <b>Rendimiento (3 mani):</b> 1,6 m <sup>2</sup> /l - Por envase (14 l): 22,4 m <sup>2</sup> <b>Color:</b> blanco y colorido	

tecniche	certificazioni	proprietà	tecnologie
 WATER BASED  BRUSH  ROLLER  AIRLESS	 incapsula amianto	 V3 BREATHABLE	 resistance 5

## amianfix

scheda  
tecnicadata  
sheetficha  
técnica

fissativo per incapsulamento amianto	esterno	fixative for asbestos encapsulation	outdoor	fijador para encapsulado de amianto	exterior
Fissativo acrilico impregnante a base d'acqua, formulato per l'inertizzazione di materiali contenenti fibre d'amianto, al fine di procedere alla loro successiva rimozione. Conforme al decreto del Ministero della Sanità del 20 Agosto 1999 per rivestimenti incapsulanti tipo D. Per uso professionale.		Water-based acrylic impregnating fixative, formulated for materials containing asbestos fibres, to render them inert so that they can be removed. Compliant with the decree issued by the Italian Ministry of Health on 20 August 1999 governing type D encapsulating coatings. For professional use.		Fijador acrilico impregnante a base de agua, formulado para la inertización de materiales que contengan fibras de amianto, a fin de proceder a su posterior retirada. Conforme al decreto del Ministerio de Sanidad Italiano de 20 de agosto de 1999 para revestimientos encapsulantes de tipo D. Para uso profesional.	
<b>Attrezzatura:</b> pennello, airless <b>Diluizione:</b> acqua - 100% <b>Resa (1 mano):</b> 8 m <sup>2</sup> /l - Per confezione (25 l): 200 m <sup>2</sup> <b>Colore:</b> rosso ossido		<b>Equipment:</b> brush, airless <b>Dilution:</b> water - 100% <b>Coverage (1 coat):</b> 8 m <sup>2</sup> /l - Per packaging (25 l): 200 m <sup>2</sup> <b>Color:</b> oxide red		<b>Herramientas:</b> brocha, pistola pulverizadora <b>Dilución:</b> agua - 100% <b>Rendimiento (1 capa):</b> 8 m <sup>2</sup> /l - Por envase (25 l): 200 m <sup>2</sup> <b>Color:</b> rojo óxido	

tecniche	certificazioni	proprietà	tecnologie
 WATER BASED  BRUSH  AIRLESS			

## muralpac liscio



scheda  
tecnica



data  
sheet



ficha  
técnica



pittura a base di Pliolite®	esterno	Pliolite® based paint	outdoor	pintura a base de Pliolite®	exterior
<p>Pittura a base di Pliolite formulata con resine sintetiche insaponificabili, riempitivi naturali e pigmenti selezionati resistenti alla luce ed alle più gravose condizioni atmosferiche. Autopulente ed impermeabile con formulazione bilanciata per essere insensibile all'acqua pur permettendo la perfetta traspirazione del supporto. Particolarmente indicato per la protezione del calcestruzzo, anche se ammalorato. Per uso professionale.</p>		<p>Pliolite® based paint paint based on unsaponifiable synthetic resins, natural fillers and selected pigments resistant to light and the most severe weather conditions. Self-cleaning and waterproof, formulated to be unaffected by water while still allowing the substrate to breathe perfectly. Particularly suited to protect concrete, even if deteriorated. For professional use.</p>		<p>Formulada con resinas sintéticas insaponificables, rellenos naturales y pigmentos seleccionados resistentes a la luz y a las condiciones atmosféricas más exigentes. Autolimpiadora e impermeable, formulación equilibrada para ser insensible al agua si bien permite la perfecta transpiración del soporte. Particolarmente indicada para la protección del hormigón, incluso si está deteriorado. Para uso profesional.</p>	
<p><b>Attrezzatura:</b> pennello, rullo, airless <b>Diluizione:</b> Diluente Sintetico - 8-10% <b>Resa (2 mani):</b> 4-5 m<sup>2</sup>/l - Per confezione (16 l): 80 m<sup>2</sup> <b>Colore:</b> bianco e colorato</p>		<p><b>Equipment:</b> brush, roller, airless <b>Dilution:</b> Diluente Sintetico - 8-10% <b>Coverage (2 coats):</b> 4-5 m<sup>2</sup>/l - Per packaging (16 l): 80 m<sup>2</sup> <b>Color:</b> white and colored</p>		<p><b>Herramientas:</b> brocha, rodillo, pistola pulverizadora <b>Dilución:</b> Diluente Sintetico - 8-10% <b>Rendimiento (2 capas):</b> 4-5 m<sup>2</sup>/l - Por envase (16 l): 80 m<sup>2</sup> <b>Color:</b> blanco y colorido</p>	

tecniche	certificazioni	proprietà	tecnologie
SOLVENT BASED BRUSH ROLLER AIRLESS		V3 BREATHABLE	resistance 4

## bitum flex



scheda  
tecnica



data  
sheet



ficha  
técnica



protettivo antiruggine bituminoso	esterno	bituminous rust proofing protective coating	outdoor	protector antióxido bituminoso	exterior
<p>Protettivo antiruggine bituminoso per carpenterie metalliche, a base di catrame, specificamente formulato per la protezione di strutture, tubazioni, pluviali in metallo e lamiera zincata. Per uso professionale.</p>		<p>Bitumen-based rustproofing protective coating for structural steel. Specially formulated to protect metal and galvanised sheet structures, piping and downpipes. For professional use.</p>		<p>Protector antióxido bituminoso para carpenterías metálicas, con base de alquitrán, específicamente formulado para la protección de estructuras, tuberías, tubos para bajada de aguas pluviales en metal y chapa galvanizada. Para uso profesional.</p>	
<p><b>Attrezzatura:</b> pennello, rullo, airless <b>Diluizione:</b> Diluente Nitro Antinebbia - pennello, rullo 2%, airless 5-7% <b>Resa (1 mano):</b> 8-9 m<sup>2</sup>/l - Per confezione (16 l): 120 m<sup>2</sup> <b>Colore:</b> nero</p>		<p><b>Equipment:</b> brush, roller, airless <b>Dilution:</b> Diluente Nitro Antinebbia - brush, roller 2%, airless 5-7% <b>Coverage (1 coat):</b> 8-9 m<sup>2</sup>/l - Per packaging (16 l): 120 m<sup>2</sup> <b>Color:</b> black</p>		<p><b>Herramientas:</b> brocha, rodillo, pistola pulverizadora <b>Dilución:</b> Diluente Nitro Antinebbia - brocha, rodillo 2%, pistola pulverizadora 5-7% <b>Rendimiento (1 capa):</b> 8-9 m<sup>2</sup>/l - Por envase (16 l): 120 m<sup>2</sup> <b>Color:</b> negro</p>	

tecniche	certificazioni	proprietà	tecnologie
SOLVENT BASED BRUSH ROLLER AIRLESS		satin BRILLIANCE	resistance 3

## detergente ac

scheda  
tecnicadata  
sheetficha  
técnica

detergente acido per prodotti lapidei	<b>interno esterno</b>	acid detergent for stone products	<b>indoor outdoor</b>	detergente ácido para productos de piedra	<b>interior exterior</b>
Detergente acido per la pulizia e rimozione efflorescenze dovute alla risalita di Sali solubili sulla superficie di fughe e piastrelle oltre alla rimozione di formazioni calcaree. Per uso professionale.		Acid detergent for the cleaning and removal of efflorescence due to the rise of soluble salts on the surface of joints and tiles as well as for the removal of scale. For professional use.		Detergente ácido para la limpieza y eliminación de eflorescencias debidas a la expansión de las sales solubles sobre la superficie de las juntas y de las baldosas, así como para la eliminación de formaciones calcáreas. Para uso profesional.	
<b>Attrezzatura:</b> pennello, rullo, airless <b>Diluizione:</b> pronto all'uso <b>Resa</b> (2 mani): 6-8 m <sup>2</sup> /l - Per confezione (25 l): 150-200 m <sup>2</sup> <b>Colore:</b> incolore		<b>Equipment:</b> brush, roller, airless <b>Dilution:</b> ready to use <b>Coverage</b> (2 coats): 6-8 m <sup>2</sup> /l - Per packaging (25 l): 150-200 m <sup>2</sup> <b>Color:</b> colourless		<b>Herramientas:</b> brocha, rodillo, pistola pulverizadora <b>Dilución:</b> listo para usar <b>Rendimiento</b> (2 capas): 6-8 m <sup>2</sup> /l - Por envase (25 l): 150-200 m <sup>2</sup> <b>Color:</b> incoloro	

tecniche	certificazioni	proprietà	tecnologie
 BRUSH  ROLLER  AIRLESS  READY TO USE			

## grafinet

scheda  
tecnicadata  
sheetficha  
técnica

detergente per rimozione di graffiti	<b>esterno</b>	detergent to remove graffiti	<b>outdoor</b>	detergente para eliminar grafitis	<b>exterior</b>
Liquido viscoso da utilizzare per la rimozione di graffiti originati da spray. Per uso professionale		Viscous liquid detergent to remove spray-painted graffiti. For professional use		Líquido viscoso a utilizar para eliminar los grafitis hechos con espray. Para uso profesional.	
<b>Attrezzatura:</b> pennello <b>Diluizione:</b> pronto all'uso <b>Resa</b> (1 mano): 4-5 m <sup>2</sup> /l - Per confezione (5 l): 25 m <sup>2</sup> <b>Colore:</b> incolore		<b>Equipment:</b> brush <b>Dilution:</b> ready to use <b>Coverage</b> (1 coat): 4-5 m <sup>2</sup> /l - Per packaging (5 l): 25 m <sup>2</sup> <b>Color:</b> colourless		<b>Herramientas:</b> brocha <b>Dilución:</b> listo para usar <b>Rendimiento</b> (1 capa): 4-5 m <sup>2</sup> /l - Por envase (5 l): 25 m <sup>2</sup> <b>Color:</b> incoloro	

tecniche	certificazioni	proprietà	tecnologie
 BRUSH  READY TO USE			

## stonet

scheda  
tecnicadata  
sheetficha  
técnica

detergente lapideo	<b>esterno</b>	stone detergent	<b>outdoor</b>	detergente para piedra	<b>exterior</b>
Detergente liquido viscoso idoneo per supporti quali pietre, mattoni, gres, clinker, graniti e materiali lapidei. Il prodotto, se adeguatamente usato, non intacca i supporti trattati. Per uso professionale		Viscous liquid detergent suitable for substrates such as stone, brick, porcelain stoneware, clinker, granite and stone materials. If properly used, the product does not affect the treated substrates. For professional use		Detergente líquido viscoso adecuado para soportes como piedra, ladrillo, gres, clinker, granito y materiales lapídeos. El producto, si se usa correctamente, no marca los soportes tratados. Para uso profesional.	
<b>Attrezzatura:</b> pennello <b>Diluizione:</b> pronto all'uso <b>Resa</b> (1 mano): 4-5 m <sup>2</sup> /l - Per confezione (25 l): 125 m <sup>2</sup> <b>Colore:</b> incolore		<b>Equipment:</b> brush <b>Dilution:</b> ready to use <b>Coverage</b> (1 coat): 4-5 m <sup>2</sup> /l - Per packaging (25 l): 125 m <sup>2</sup> <b>Color:</b> colourless		<b>Herramientas:</b> brocha <b>Dilución:</b> listo para usar <b>Rendimiento</b> (1 capa): 4-5 m <sup>2</sup> /l - Por envase (25 l): 125 m <sup>2</sup> <b>Color:</b> incoloro	

tecniche	certificazioni	proprietà	tecnologie
 WATER BASED  BRUSH  READY TO USE			

## zincobrill



scheda  
tecnica



data  
sheet



ficha  
técnica



pittura per coperture bituminose e manufatti metallici	<b>esterno</b>	paint for bituminous coverings and metal items	<b>outdoor</b>	pintura para cubiertas bituminosas y elementos metálicos	<b>exterior</b>
Pittura sintetica a base alchidica con modificanti in unione a pasta di alluminio, buon potere coprente, resistente al calore, alto potere riflettente e buone proprietà protettive contro la ruggine. Per uso professionale.		Alkyd-based, highly reflective, synthetic paint with modifiers in combination with aluminium paste. Provides good coverage, heat resistance and protects against rust. For professional use.		Pintura sintética con base alquídica con modificantes y pasta de aluminio, con buena capacidad cubriente, resistente al calor, alto poder reflectante y buenas propiedades protectoras contra el óxido. Para uso profesional.	
<b>Attrezzatura:</b> pennello, rullo, airless <b>Diluizione:</b> pronto all'uso <b>Resa</b> (2 mani): 6,5-7 m <sup>2</sup> /l - Per confezione (16 l): 112 m <sup>2</sup> <b>Colore:</b> alluminio		<b>Equipment:</b> brush, roller, airless <b>Dilution:</b> ready to use <b>Coverage</b> (2 coats): 6,5-7 m <sup>2</sup> /l - Per packaging (16 l): 112 m <sup>2</sup> <b>Color:</b> aluminium		<b>Herramientas:</b> brocha, rodillo, pistola pulverizadora <b>Dilución:</b> listo para usar <b>Rendimiento</b> (2 capas): 6,5-7 m <sup>2</sup> /l - Por envase (16 l): 112 m <sup>2</sup> <b>Color:</b> aluminio	

tecniche					certificazioni				proprietà				tecnologie			
SOLVENT BASED	BRUSH	ROLLER	AIRLESS	READY TO USE												

## spartitraffico



scheda  
tecnica



data  
sheet



ficha  
técnica



pittura per segnaletica stradale	<b>esterno</b>	paint for road marking	<b>outdoor</b>	pintura para demarcación vial	<b>exterior</b>
Pittura al solvente a base di resine gliceroftaliche modificate e clorocaucciù, altamente resistente ed aderente, appositamente formulata per segnaletica stradale. Essiccazione rapida. Prodotto anche nella versione rifrangente secondo Capitolato ANAS. Per uso professionale.		Solvent-based paint containing modified glycerophthalic resins and chlorinated rubber, highly resistant and adhesive. Specially formulated for road marking. Fast drying. Also available in reflecting version as per ANAS Specifications. For outdoor use. For professional use.		Pintura al disolvente con base de resinas gliceroftálicas modificadas y clorocaucho, altamente resistente y adherente, expresamente formulada para demarcación vial. Secado rápido. Producida también en la versión reflectante conforme a las Especificaciones ANAS. Para uso profesional.	
<b>Attrezzatura:</b> traccialinee stradali, pennello, rullo, airless <b>Diluizione:</b> Diluente per Spartitraffico - 10-15% <b>Resa</b> (1 mano): 12,5-25 m - Per confezione (16 l): 200-400 m <b>Colore:</b> bianco, giallo, blu e rifrangente		<b>Equipment:</b> road marking, brush, roller, airless <b>Dilution:</b> Diluente per Spartitraffico - 10-15% <b>Coverage</b> (1 coat): 12,5-25 m - Per packaging (16 l): 200-400 m <b>Color:</b> white, yellow, blue and reflective		<b>Herramientas:</b> traccialinee stradali, brocha, rodillo, pistola pulverizadora <b>Dilución:</b> Diluente per Spartitraffico - 10-15% <b>Rendimiento</b> (1 capa): 12,5-25 m - Por envase (16 l): 200-400 m <b>Color:</b> blanco, amarillo, azul y reflectante	

tecniche					certificazioni				proprietà				tecnologie				
SOLVENT BASED	BRUSH	ROLLER	AIRLESS						WALKABLE								

## sverniciatore n11

scheda  
tecnicadata  
sheetficha  
técnica

prodotto decapante	interno esterno	pickling product	indoor outdoor	producto decapante	interior exterior
Prodotto decapante esente da cloruro di metilene, studiato per asportare qualsiasi tipo di pittura, vernice o rivestimento già essiccato indipendentemente dalla sua anzianità o natura. Per uso professionale.		Pickling product free from methylene chloride, designed to remove any type of paint, varnish or coating that has already dried regardless of its age or nature. For professional use.		Producto decapado libre de cloruro de metileno, diseñado para eliminar cualquier tipo de pintura, barniz o revestimiento que ya se haya secado independientemente de su edad o naturaleza. Para uso profesional.	
<b>Attrezzatura:</b> pennello <b>Diluizione:</b> pronto all'uso <b>Resa:</b> (1 mano): 2-3 m <sup>2</sup> /l - Per confezione (20 l): 50 m <sup>2</sup> <b>Colore:</b> alluminio		<b>Equipment:</b> brush <b>Dilution:</b> ready to use <b>Coverage</b> (1 coat): 2-3 m <sup>2</sup> /l - Per packaging (20 l): 50 m <sup>2</sup> <b>Color:</b> aluminium		<b>Herramientas:</b> brocha <b>Dilución:</b> listo para usar <b>Rendimiento</b> (1 capa): 2-3 m <sup>2</sup> /l - Por envase (20 l): 50 m <sup>2</sup> <b>Color:</b> aluminio	

tecniche	certificazioni	proprietà	tecnologie
 SOLVENT BASED  BRUSH  READY TO USE			

## bio-past

scheda  
tecnicadata  
sheetficha  
técnica

additivo antimuffa	anti-mold additive	aditivo anti-moho
Additivo a base di prodotti insolubili in acqua, idoneo a rendere il film delle idropitture protetto dall'attacco di muffe e microrganismi. Non dà alterazioni nel colore né addensamenti. Per uso professionale.	Additive based on water-insoluble products, suitable for making the film of water-based paints protected from the attack of molds and microorganisms. It does not give alterations in color or thickening. For professional use.	Aditivo a base de productos insolubles en agua, apto para realizar la película de pinturas al agua protegidas del ataque de mohos y microorganismos. No da alteraciones de color ni engrosamiento. Para uso profesional.
<b>Modalità di utilizzo:</b> aggiungere la confezione di BIO-PAST (0,250 l) in 5 l di idropittura mescolando per almeno 2 minuti <b>Colore:</b> bianco	<b>How to use:</b> Add the package of BIOPAST (250 g) to 5 l of a water-based paint and stir for at least 2 minutes <b>Color:</b> white	<b>Modo de empleo:</b> añadir el paquete de BIOPAST (0,250 l) en 5 l de pintura al agua, mezclando durante al menos 2 minutos. <b>color:</b> blanco

tecniche	certificazioni	proprietà	tecnologie
 WATER BASED  READY TO USE			

## catalizzatore z8



scheda  
tecnica



data  
sheet



ficha  
técnica



catalizzatore poliuretanico	interno esterno	polyurethane catalyst	indoor outdoor	catalizador de poliuretano	interior exterior
Catalizzatore poliuretanico per prodotti sintetici ai quali si richiedano particolari resistenze all'abrasione, notevole durezza superficiale, maggiore rapidità di essiccazione, migliorandone la resistenza nel tempo. Idoneo per Marineria, Crystal e Crystal SX. Per uso professionale.		Polyurethane catalyst for synthetic products which require particular resistance to abrasion, considerable surface hardness, faster drying, improving their resistance over time. Suitable for Marineria, Crystal, Crystal SL and Crystal SX. For professional use.		Catalizador de poliuretano para productos sintéticos que requieran especial resistencia a la abrasión, considerable dureza superficial, secado más rápido, mejorando su resistencia con el tiempo. Adecuado para Marineria, Crystal, y Crystal SX. Para uso profesional.	
<b>Diluizione:</b> pronto all'uso <b>Modalità di utilizzo:</b> Marineria 8,5:1,5 (in volume). Miscelare fino ad omogeneizzazione. Diluire in seguito il prodotto secondo la rispettiva scheda tecnica <b>Colore:</b> incolore		<b>Dilution:</b> ready to use <b>How to use:</b> Marineria 8,5:1,5. Mix the resulting mixture until smooth. Then dilute the product following the indications on the Technical Data Sheets <b>Color:</b> colourless		<b>Dilución:</b> listo para usar <b>Modo de uso:</b> Marinería 8,5:1,5 (en volumen). Mezclar hasta homogeneización. Diluir posteriormente el producto según la respectiva ficha técnica <b>Color:</b> incoloro	

tecniche	certificazioni	proprietà	tecnologie
 			

## armatex micro



scheda  
tecnica



data  
sheet



ficha  
técnica



rete in fibra di vetro	interno esterno	fiberglass net	indoor outdoor	malla de fibra de vidrio	interior exterior
Rete tessuta in fibra di vetro impiegata come armatura per cicli elastomerici.		Woven glass fibre mesh used as reinforcement for elastomeric cycles.		Malla tejida de fibra de vidrio utilizada como refuerzo para ciclos elastoméricos.	
<b>Attrezzatura:</b> coltello a lame intercambiabili (tipo Stanley), frattazzo metallico <b>Grammatura:</b> 70 g/m <sup>2</sup> <b>Resa:</b> 1,10 m <sup>2</sup> di rete per 1 m <sup>2</sup> di supporto (comprese le necessarie sovrapposizioni). <b>Misura:</b> 1 x 50 m per totali 50 m <sup>2</sup>		<b>Equipment:</b> Knife with interchangeable blades (Stanley type), metal trowel <b>Grammatura:</b> 70 g/m <sup>2</sup> <b>Coverage:</b> 1,10 m <sup>2</sup> network for 1 m <sup>2</sup> of support (including the necessary overlapping). <b>Size:</b> 1 x 50 m per tot. 50 m <sup>2</sup>		<b>Herramientas:</b> cuchillo de hoja intercambiable (tipo Stanley), llana de metal <b>Grammatura:</b> 70 g/m <sup>2</sup> <b>Rendimiento:</b> 1,10 m <sup>2</sup> de malla por 1 m <sup>2</sup> de soporte (incluidas las superposiciones necesarias). <b>Misura:</b> 1 x 50 para totales 50 m <sup>2</sup>	





**industri**

# prodotti

antiruggine per carrozzeria

epozinco

rapidex

clorex



# ria

## antiruggine per carrozzeria



scheda  
tecnica



data  
sheet



ficha  
técnica



fondo antiruggine alchidico	<b>interno esterno</b>	oleophenolic rust proofing base coat	<b>indoor outdoor</b>	fondo antióxido alquídico	<b>interior exterior</b>
Fondo antiruggine alchidico a rapida essiccazione per verniciature industriali a base di resine alchiliche corto olio e modificazioni fenoliche, pigmento antiruggine di elevata qualità. Resistente alla sovraspruzzatura con nitro. Per uso professionale.		Fast drying rustproofing alkyd base coat for industrial painting containing short oil alkyd resins with phenolic modifications and high quality rustproofing pigment. It can resist overspraying with nitro-based products. For professional use.		Fondo antióxido alquídico de secado rápido para operaciones de pintado industrial a base de resinas alquídicas, de aceite corto y modificaciones fenólicas, pigmento antióxido de alta calidad. Resistente a recubrimiento nitro con pistola. Para uso profesional.	
<b>Attrezzatura:</b> pennello, rullo, airless <b>Diluizione:</b> Diluente Nitro Antinebbia - max 10% <b>Resa</b> (1 mano): 8-10 m <sup>2</sup> /l - Per confezione (10 l): 100 m <sup>2</sup> <b>Colore:</b> bianco e colorato		<b>Equipment:</b> brush, roller, airless <b>Dilution:</b> Diluente Nitro Antinebbia - max 10% <b>Coverage</b> (1 coat): 8-10 m <sup>2</sup> /l - Per packaging (10 l): 100 m <sup>2</sup> <b>Color:</b> white and colored		<b>Herramientas:</b> brocha, rodillo, pistola pulverizadora <b>Dilución:</b> Diluente Nitro Antinebbia - max 10% <b>Rendimiento</b> (1 capa): 8-10 m <sup>2</sup> /l - Por envase (10 l): 100 m <sup>2</sup> <b>Color:</b> blanco y colorido	

tecniche	certificazioni	proprietà	tecnologie
SOLVENT BASED BRUSH ROLLER AIRLESS		matt BRILLIANCE	

## epozinco



scheda  
tecnica



data  
sheet



ficha  
técnica



fondo antiruggine epossidico	<b>interno esterno</b>	rust proofing epoxy base coat	<b>indoor outdoor</b>	fondo antióxido epoxídico	<b>interior exterior</b>
Fondo antiruggine epossidico dotato di ottima aderenza su tutti i supporti metallici, ottima resistenza agli agenti chimici ed all'esposizione in atmosfera industriale e marina. Idoneo come primer su manufatti metallici in ferro lega leggera e lamiera zincata quali impianti industriali, parti di macchinari, tubazioni, palificazioni, soggetti ad aggressioni di particolare gravità. Per uso professionale.		Rust proofing epoxy base coat providing excellent adhesion on all metal substrates, superb resistance to chemical agents and exposure to industrial and marine atmospheres. Ideal for use as primer on light steel and galvanised sheet items — such as industrial plants, machinery parts, piping and poles — subject to particularly aggressive environments. For professional use.		Fondo antióxido epoxídico dotato de excelente adherencia en todos los soportes metálicos, excelente resistencia a los agentes químicos y a la exposición en atmósfera industrial y marina. Idóneo como imprimación sobre elementos metálicos en hierro, aleación ligera y chapa galvanizada, como equipos industriales, partes de maquinarias, tuberías, postes y pilotes, sujetos a agresiones particularmente graves. Para uso profesional.	
<b>Attrezzatura:</b> pennello, rullo, airless <b>Rapporto di catalisi:</b> (A:B) 4:0,64 in volume <b>Diluizione:</b> Diluente per Epossidici - rullo: 5-7%; airless: 7-15%; pennello 5-10% <b>Resa</b> (1 mano): 6-7 m <sup>2</sup> /l - Per confezione (4 kg + 0,64 kg): 35 m <sup>2</sup> <b>Color:</b> grigio		<b>Equipment:</b> brush, roller, airless <b>Ratio of catalysis:</b> (A:B) 4:0,64 in volume <b>Dilution:</b> Diluente per Epossidici - roller: 5-7%; airless: 7-15%; brush 5-10% <b>Coverage</b> (1 coat): 6-7 m <sup>2</sup> /l - Per packaging (4 kg + 0,64 kg): 35 m <sup>2</sup> <b>Color:</b> gray		<b>Herramientas:</b> brocha, rodillo, pistola pulverizadora <b>Relación de mezcla:</b> (A:B) 4:0,64 in volume <b>Dilución:</b> Diluente per Epossidici - rodillo 5-7%; pistola pulverizadora 7-15%; brocha 5-10% <b>Rendimiento</b> (1 capa): 6-7 m <sup>2</sup> /l - Por envase (4 kg + 0,64 kg): 35 m <sup>2</sup> <b>Color:</b> gris	

tecniche	certificazioni	proprietà	tecnologie
SOLVENT BASED BRUSH ROLLER AIRLESS		satin BRILLIANCE	resistance 3

## rapidex



scheda  
tecnica



data  
sheet



ficha  
técnica



smalto sintetico alchidico	<b>interno esterno</b>	synthetic alkyd enamel	<b>indoor outdoor</b>	esmalte sintético alquídico	<b>interior exterior</b>
<p>Smalto sintetico industriale a rapida essiccazione a base di resine alchiliche, corto olio e pigmenti selezionati resistenti alla luce. Ottima resistenza all'acqua ed agli agenti atmosferici indicato per verniciature di veicoli industriali, macchine agricole e profilati di ferro esenti da ruggine, grasso e calamina. Per uso professionale.</p>		<p>Fast-drying, synthetic industrial enamel based on short oil alkyd resins and selected light-resistant pigments. Superb resistance to water and the weather. Suitable for painting industrial vehicles, agricultural machinery and iron profiles that are free of rust, grease and mill scale. For professional use.</p>		<p>Esmalte sintético industrial de secado rápido con base de resinas alquídicas, de aceite corto y pigmentos seleccionados resistentes a la luz. Excelente resistencia al agua y a los agentes atmosféricos, indicado para pintado de vehículos industriales, máquinas agrícolas y perfilados de hierro limpios de óxido, grasa y carbonillas. Para uso profesional.</p>	
<p><b>Attrezzatura:</b> airless <b>Diluizione:</b> Diluente Nitro Antinebbia - 10% <b>Resa</b> (2 mani): 4-5 m<sup>2</sup>/l - Per confezione (10 l): 50 m<sup>2</sup> <b>Colore:</b> bianco e colorato</p>		<p><b>Equipment:</b> airless <b>Dilution:</b> Diluente Nitro Antinebbia - 10% <b>Coverage</b> (2 coats): 4-5 m<sup>2</sup>/l - Per packaging (10 l): 50 m<sup>2</sup> <b>Color:</b> white and colored</p>		<p><b>Herramientas:</b> pistola pulverizadora <b>Dilución:</b> Diluente Nitro Antinebbia - 10% <b>Rendimiento</b> (2 capas): 4-5 m<sup>2</sup>/l - Por envase (10 l): 50 m<sup>2</sup> <b>Color:</b> blanco y colorido</p>	

tecniche	certificazioni	proprietà	tecnologie

## clorex



scheda  
tecnica



data  
sheet



ficha  
técnica



smalto alchidico cloroaccciù	<b>esterno</b>	alkyd chlorinated rubber enamel	<b>outdoor</b>	esmalte alquídico de cloro Caucho	<b>exterior</b>
<p>Smalto combinato a base di resine cloroaccciù e alchidiche, pigmenti resistenti agli agenti atmosferici. Indicato ove sia necessaria una forte resistenza alla corrosione atmosferica. Per uso professionale.</p>		<p>Combination chlorinated rubber and alkyd resins-based enamel containing weather-resistant pigments. Suitable whenever high resistance to corrosive atmospheres is required. For professional use.</p>		<p>Esmalte combinado a base de resinas de cloro Caucho y alquídicas, pigmentos resistentes a los agentes atmosféricos. Indicado allí donde se necesite una fuerte resistencia a la corrosión atmosférica. Para uso profesional.</p>	
<p><b>Attrezzatura:</b> pennello, rullo, airless <b>Diluizione:</b> Diluente Nitro Antinebbia - 15% <b>Resa</b> (2 mani): 4-5 m<sup>2</sup>/kg - Per confezione (20 kg): 100 m<sup>2</sup> <b>Colore:</b> bianco e colorato</p>		<p><b>Equipment:</b> brush, roller, airless <b>Dilution:</b> Diluente Nitro Antinebbia - 15% <b>Coverage</b> (2 coats): 4-5 m<sup>2</sup>/kg - Per packaging (20 kg): 100 m<sup>2</sup> <b>Color:</b> white and colored</p>		<p><b>Herramientas:</b> brocha, rodillo, pistola pulverizadora <b>Dilución:</b> Diluente Nitro Antinebbia - 15% <b>Rendimiento</b> (2 capas): 4-5 m<sup>2</sup>/kg - Por envase (20 kg): 100 m<sup>2</sup> <b>Color:</b> blanco y colorido</p>	

tecniche	certificazioni	proprietà	tecnologie



# diluenti



## sintetico

Diluyente sintetico per la diluizione di smalti sintetici e oleosintetici.	Synthetic thinner to dilute synthetic and oleosynthetic enamels	Diluyente sintético para esmaltes sintéticos y oleosintéticos.
Per: Aderlac HQ, Cerato Opaco, Fondo per Legno, Marineria, Marineria Opaco, Micafer, Minio Oleofenolico, Muralpac Liscio, Rusty	For: Aderlac HQ, Cerato Opaco, undercoat for wood, Marineria, Marineria Opaco, Micafer, Minio Oleofenolico, Muralpac Liscio, Rusty	para: Aderlac HQ, Cerato Opaco, Fondo per Legno, Marineria, Marineria Opaco, Micafer, Minio Oleofenolico, Muralpac Liscio, Rusty



## nitro antinebbia

Miscela di solventi organici. Per la diluizione di tutti i prodotti a base nitro ed a rapida essiccazione.	Blend of organic solvents. Used to dilute all nitro-based and fast-drying products.	Mezcla de disolventes orgánicos. Para diluir todos los productos con base nitro y de secado rápido.
Per: Antiruggine per Carrozzeria, Bitum Flex, Cloro-Pool, Clorex, Nitrofix, Rapidex.	For: Antiruggine per Carrozzeria, Bitum Flex, Cloro-Pool, Clorex, Nitrofix, Rapidex.	para: Antiruggine per Carrozzeria, Bitum Flex, Cloro-Pool, Clorex, Nitrofix, Rapidex.



## per spartitraffico

Diluyente specifico per finiture spartitraffico.	Specific thinner for spartitraffico paint	Diluyente específico para acabados con spartitraffico.
<b>Per: Spartitraffico</b>	<b>For: Spartitraffico</b>	<b>Para: Spartitraffico</b>



## per epossidici

Diluyente specifico per finiture epossidiche.	Specific thinner for epoxy topcoats.	Diluyente específico para acabados epoxídicos.
Per: Epozinco, Epoxy Fondo, Epoxy Paint HT, Primer-Pool, Epoxy Fondo AS, Epoxy Fondo Oil, Polyelastic, Epoxy Paint LT.	For: Epozinco, Epoxy Undercoat, Epoxy Paint HT, Primer-Pool, Epoxy Undercoat AS, Epoxy Undercoat Oil, Polyelastic, Epoxy Paint LT.	para: Epozinco, Epoxy Fondo, Epoxy Paint HT, Primer-Pool, Epoxy Fondo AS, Epoxy Fondo Oil, Polyelastic, Epoxy Paint LT.



## per poliuretanic

Diluyente poliuretanic per la diluizione di fondi e finiture lucide e opache poliuretaniche.	Polyurethane thinner to dilute gloss and matt polyurethane base coats and topcoats.	Diluyente poliuretánico para fondos y acabados poliuretánicos brillantes y mates.
Per: Betonglass, Ivaglass, Paviglass.	For: Betonglass, Ivaglass, Paviglass.	para: Betonglass, Ivaglass, Paviglass.





**linea pi**

# prodotti

primer-pool

inter-pool

cloro-pool

# iscine

## primer-pool



scheda  
tecnica



data  
sheet



ficha  
técnica



primer epossidico per piscine	esterno	epoxy primer for swimming pools	outdoor	imprimación epoxídica para piscinas	exterior
<p>Primer epossidico bicomponente a solvente con ottima resistenza agli agenti atmosferici e chimici, idoneo per applicazioni in atmosfera industriale, piscine ed acqua di mare. Particolarmente indicato come mano di impregnazione e promotore di aderenza quando il manufatto debba essere finito con pitture epossidiche, epossiviniliche, poliuretatiche o clorocaucciù. Per uso professionale.</p>		<p>Two-pack solvent-based epoxy primer with superb resistance to atmospheric and chemical agents, ideal for applications in industrial atmospheres, swimming pools and sea water. Particularly suitable as impregnation coat and adhesion promoter when the item is to be finished with epoxy, epoxyvinyl, polyurethane or chlorinated-rubber paints. For professional use.</p>		<p>Imprimación epoxídica bicomponente con disolvente, de excelente resistencia a los agentes atmosféricos y químicos, idóneo para aplicaciones en atmósfera industrial, piscinas y agua de mar. Particolarmente indicada como mano de impregnación y promotor de adherencia cuando la superficie deba recibir un acabado con pinturas epoxídicas, epoxivinilicas, poliuretánicas o de clorocaucho. Para uso profesional.</p>	
<p><b>Attrezzatura:</b> pennello, rullo <b>Rapporto di catalisi:</b> (A:B) 1:1 <b>Diluizione:</b> Diluente per Epossidici - max 5% <b>Resa</b> (1 mano): 5-7 m<sup>2</sup>/kg - Per confezione (4 kg + 4 kg): 56 m<sup>2</sup> <b>Colore:</b> incolore</p>		<p><b>Equipment:</b> brush, roller <b>Ratio of catalysis:</b> (A:B) 1:1 <b>Dilution:</b> Diluente per Epossidici - max 5% <b>Coverage</b> (1 coat): 5-7 m<sup>2</sup>/kg - Per packaging (4 kg + 4 kg): 56 m<sup>2</sup> <b>Color:</b> colourless</p>		<p><b>Herramientas:</b> brocha, rodillo <b>Relación de mezcla:</b> (A:B) 1:1 <b>Dilución:</b> Diluente per Epossidici - max 5% <b>Rendimiento</b> (1 capa): 5-7 m<sup>2</sup>/kg - Por envase (4 kg + 4 kg): 56 m<sup>2</sup> <b>Color:</b> incoloro</p>	

tecniche	certificazioni	proprietà	tecnologie
SOLVENT BASED BRUSH ROLLER		satin BRILLIANCE	

## inter-pool



scheda  
tecnica



data  
sheet



ficha  
técnica



intermedio epossidico per piscine	esterno	epoxy intermediate coating for swimming pools	outdoor	revestimiento epoxídico para piscinas	exterior
<p>Rivestimento intermedio epossidico bicomponente a solvente, costituito con indurenti e riempitivi appropriati. Presenta elevata resistenza chimica e all'immersione in acqua dolce e salata. Idoneo anche per applicazioni verticali, in quanto ha sufficienti requisiti di resistenza alla colatura. Idoneo come mano intermedia per cicli anticorrosivi e cicli per piscine. Per uso professionale.</p>		<p>Two-pack solvent-based epoxy intermediate coating consisting of appropriate curing agents and fillers. It offers high resistance to chemicals and immersion in fresh and salt water. Also ideal for vertical applications since it is quite resistant to dripping. Suitable as intermediate coat for anti-corrosion and swimming pool application processes. For professional use.</p>		<p>Revestimiento intermedio epoxídico bicomponente con disolvente, constituido con endurecedores y rellenos adecuados. Presenta alta resistencia química y a la inmersión en agua dulce y salada. Idóneo también para aplicaciones verticales, dado que posee suficientes requisitos de resistencia a la formación de goterones. Idóneo como mano intermedia para ciclos anticorrosivos y ciclos para piscinas. Para uso profesional.</p>	
<p><b>Attrezzatura:</b> rullo, frattazzo o staggia <b>Rapporto di catalisi:</b> (A:B) 1:1 <b>Diluizione:</b> pronto all'uso <b>Resa</b> (1 mano): 3-3,5 m<sup>2</sup>/kg - Per confezione (4 kg + 4 kg): 25 m<sup>2</sup> <b>Colore:</b> bianco e colorato</p>		<p><b>Equipment:</b> roller, trowel or stagger <b>Ratio of catalysis:</b> (A:B) 1:1 <b>Dilution:</b> ready to use <b>Coverage</b> (1 coat): 3-3,5 m<sup>2</sup>/kg - Per packaging (4 kg + 4 kg): 25 m<sup>2</sup> <b>Color:</b> white and colored</p>		<p><b>Herramientas:</b> rodillo de lana de pelo corto, lana o regla <b>Relación de mezcla:</b> (A:B) 1:1 <b>Dilución:</b> listo para usar <b>Rendimiento</b> (1 capa): 3-3,5 m<sup>2</sup>/kg - Por envase (4 kg + 4 kg): 25 m<sup>2</sup> <b>Color:</b> blanco y colorido</p>	

tecniche	certificazioni	proprietà	tecnologie
SOLVENT BASED ROLLER TROWEL		satin BRILLIANCE	resistance 3

## cloro-pool



scheda  
tecnica



data  
sheet



ficha  
técnica



smalto clorocaucciù per piscine	<b>esterno</b>	chlorinated rubber enamel for swimming pools	<b>outdoor</b>	esmalte de clorocaucho para piscinas	<b>exterior</b>
Smalto combinato a base di resine clorocaucciù, pigmenti resistenti agli agenti atmosferici. Appositamente formulato per la pittura di piscine. Per uso professionale.		Combination chlorinated rubber resin-based enamel containing weather-resistant pigments. Specially formulated to paint swimming pools. For professional use.		Esmalte combinado a base de resinas de clorocaucho, pigmentos resistentes a los agentes atmosféricos. Especificamente formulado para pintar piscinas. Para uso profesional.	
<b>Attrezzatura:</b> pennello, rullo, airless <b>Diluizione:</b> Diluente Nitro Antinebbia - 15% <b>Resa</b> (2 mani): 5-6 m <sup>2</sup> /l - Per confezione (16 l): 96 m <sup>2</sup> <b>Colore:</b> azzurro		<b>Equipment:</b> brush, roller, airless <b>Dilution:</b> Diluente Nitro Antinebbia - 15% <b>Coverage</b> (2 coats): 5-6 m <sup>2</sup> /l - Per packaging (16 l): 96 m <sup>2</sup> <b>Color:</b> blue		<b>Herramientas:</b> brocha, rodillo, pistola pulverizadora <b>Dilución:</b> Diluente Nitro Antinebbia - 15% <b>Rendimiento</b> (2 capas): 5-6 m <sup>2</sup> /l - Por envase (16 l): 96 m <sup>2</sup> <b>Color:</b> azul	

tecniche				certificazioni				proprietà				tecnologie				
SOLVENT BASED	BRUSH	ROLLER	AIRLESS					BRILLIANCE					RESISTANCE 3			

### ciclo al solvente per la verniciatura di vasche e piscine a basso spessore - solvent cycle for the painting of tanks and pools low thickness - ciclo a base de disolventes para pintar tanques y piscinas bajo espesor

consolidamento / imprimitura consolidation/ priming consolidación / imprimación	finitura finish acabado
<b>primer-pool</b> pag. 122	<b>cloro-pool</b> pag. 123

### ciclo al solvente per la verniciatura di vasche e piscine a alto spessore - solvent cycle for the painting of tanks and pools high thickness - ciclo a base de disolventes para pintar tanques y piscinas alto espesor

consolidamento / imprimitura consolidation/ priming consolidación / imprimación	strato uniformante uniforming layer capa uniformante	finitura finish acabado
<b>primer-pool</b> pag. 122	<b>inter-pool</b> pag. 122	<b>cloro-pool</b> pag. 123 oppure <b>betonglass</b> pag. 59





linea le

# prodotti

marineria

marineria opaco

thinner fill

cerato

idroflatting

idroflatting opaco

idrofill

idrocerato

# egno



## marineria



scheda  
tecnica



data  
sheet



ficha  
técnica



finitura per legno	interno esterno	wood finish	indoor outdoor	acabado per legno	interior exterior
<p>Vernice trasparente uretanizzata, di elevato pregio e brillantezza. Forma un film protettivo resistente agli agenti esterni e all'attacco di muffe. Garantisce la protezione dai raggi ultravioletti. Formulata per il trattamento di manufatti situati all'esterno in ambiente marino. Per uso professionale.</p>		<p>Transparent, high quality urethanized varnish based on a blend of synthetic and urethane resins. It forms a protective film resistant to the weather and mould. To ensure protection against ultraviolet light. Formulated to treat items in wood located outdoors in marine environments. For professional use.</p>		<p>Barniz transparente uretanizado de alta calidad y brillo. Forma una película protectora resistente a los agentes externos y a los mohos. Garantizar la protección del soporte contra los rayos ultravioleta. Formulado para el tratamiento de elementos de madera expuestos a la intemperie en ambiente marino. Para uso profesional.</p>	
<p><b>Attrezzatura:</b> pennello, rullo <b>Diluizione:</b> Diluente Sintetico - 5% <b>Resa</b> (1 mano): 8 m<sup>2</sup>/l - Per confezione (15 l): 120 m<sup>2</sup> <b>Colore:</b> incolore</p>		<p><b>Equipment:</b> brush, roller <b>Dilution:</b> Diluente Sintetico - 5% <b>Coverage</b> (1 coat): 8 m<sup>2</sup>/l - Per packaging (15 l): 120 m<sup>2</sup> <b>Color:</b> colourless</p>		<p><b>Herramientas:</b> brocha, rodillo <b>Dilución:</b> Diluente Sintetico - 5% <b>Rendimiento</b> (1 capa): 8 m<sup>2</sup>/l - Por envase (15 l): 120 m<sup>2</sup> <b>Color:</b> incoloro</p>	

tecniche	certificazioni	proprietà	tecnologie
 SOLVENT BASED  BRUSH  ROLLER		 gloss BRILLIANCE	

## marineria opaco



scheda  
tecnica



data  
sheet



ficha  
técnica



finitura per legno opaca	interno esterno	matt wood finish	indoor outdoor	acabado per legno opaca	interior exterior
<p>Vernice trasparente uretanizzata, di elevato pregio. Forma un film protettivo resistente agli agenti esterni e all'attacco di muffe. Garantisce la protezione dai raggi ultravioletti. Formulata per il trattamento di manufatti situati all'esterno in ambiente marino. Per uso professionale.</p>		<p>Transparent, high quality urethanized varnish. It forms a protective film resistant to the weather and mould. Ensure protection against ultraviolet light. Formulated to treat items in wood located outdoors in marine environments. For professional use.</p>		<p>Barniz transparente uretanizado de alta calidad y brillo. Forma una película protectora resistente a los agentes externos y a los mohos. Garantizar la protección del soporte contra los rayos ultravioleta. Formulado para el tratamiento de elementos de madera expuestos a la intemperie en ambiente marino. Para uso profesional.</p>	
<p><b>Attrezzatura:</b> pennello, rullo <b>Diluizione:</b> Diluente Sintetico - 5% <b>Resa</b> (1 mano): 8 m<sup>2</sup>/l - Per confezione (15 l): 120 m<sup>2</sup> <b>Colore:</b> incolore</p>		<p><b>Equipment:</b> brush, roller <b>Dilution:</b> Diluente Sintetico - 5% <b>Coverage</b> (1 coat): 8 m<sup>2</sup>/l - Per packaging (15 l): 120 m<sup>2</sup> <b>Color:</b> colourless</p>		<p><b>Herramientas:</b> brocha, rodillo <b>Dilución:</b> Diluente Sintetico - 5% <b>Rendimiento</b> (1 capa): 8 m<sup>2</sup>/l - Por envase (15 l): 120 m<sup>2</sup> <b>Color:</b> incoloro</p>	

tecniche	certificazioni	proprietà	tecnologie
 SOLVENT BASED  BRUSH  ROLLER		 matt BRILLIANCE	

## thinner fill



scheda  
tecnica



data  
sheet



ficha  
técnica



impregnante a solvente	interno esterno	high penetrating, water-based fixative	indoor outdoor	impregnante de disolvente	interior exterior
<p>Protettivo del legno a base di resine sintetiche e additivi. Forma un film estremamente sottile, idrorepellente, fortemente resistente agli attacchi di agenti fisici esterni ed alle muffe. Penetra in profondità, non fa da pellicola, è privo di odore ad essiccazione avvenuta. Opaco. Per uso professionale.</p>		<p>Protective finish for wood containing non film-forming synthetic resins and additives. It forms a film that is extremely thin and yet highly water-repellent, resistant to external physical agents as well as to mould and mildew. It penetrates in depth.. Odourless when dry. Matt. For professional use.</p>		<p>Protector para madera con base de resinas sintéticas y aditivos. Forma una película extremadamente fina pero de gran resistencia a los ataques de agentes físicos externos y mohos. Penetra en profundidad, no se exfolia, no tiene olor una vez seco. Mate. Para uso profesional.</p>	
<p><b>Attrezzatura:</b> pennello, rullo, spruzzo <b>Diluizione:</b> pronto all'uso <b>Resa</b> (1 mano): 10-12 m<sup>2</sup>/l - Per confezione (15 l): 165 m<sup>2</sup> <b>Colore:</b> incolore e colorato</p>		<p><b>Equipment:</b> brush, roller, airless <b>Dilution:</b> ready to use <b>Coverage</b> (1 coat): 10-12 m<sup>2</sup>/l - Per packaging (15 l): 165 m<sup>2</sup> <b>Color:</b> colourless and colored</p>		<p><b>Herramientas:</b> brocha, rodillo, pistola pulverizadora <b>Dilución:</b> listo para usar <b>Rendimiento</b> (1 capa): 10-12 m<sup>2</sup>/l - Por envase (15 l): 165 m<sup>2</sup> <b>Color:</b> incolore y colorido</p>	

tecniche	certificazioni	proprietà	tecnologie
SOLVENT BASED BRUSH ROLLER AIRLESS READY TO USE		matt BRILLIANCE	

## cerato



scheda  
tecnica



data  
sheet



ficha  
técnica



impregnante a solvente cerato	interno esterno	solvent-based Wax product, impregnating agent	indoor outdoor	impregnante de disolvente encerado	interior exterior
<p>Protettivo del legno a base di resine sintetiche non filmogene e additivi idrorepellenti. Forma un film estremamente sottile, idrorepellente, fortemente resistente agli attacchi di agenti fisici esterni ed alle muffe. Penetra in profondità, non crea una pellicola superficiale, rende il legno estremamente idrorepellente. È privo di odore ad essiccazione avvenuta. Opaco. Per uso professionale.</p>		<p>Protective finish for wood containing non film-forming synthetic resins and water-repellent additives. It forms a film that is extremely thin and yet highly water-repellent, resistant to external physical agents as well as to mould and mildew. It penetrates in depth, does not form a surface film and makes the wood extremely water-repellent. For professional use.</p>		<p>Protector para la madera a base de resinas sintéticas no filmógenas y aditivos hidro-repelentes. Forma una película extremadamente fina, hidro-repelente, de gran resistencia a los ataques de agentes físicos externos y mohos. Penetra en profundidad, no crea película superficial, dota a la madera de una extrema calidad hidro-repelente. Una vez seco, no desprende olor. Mate. Para uso profesional.</p>	
<p><b>Attrezzatura:</b> pennello, rullo, spruzzo <b>Diluizione:</b> Diluente Sintetico - 5-10% <b>Resa</b> (1 mano): 9-11 m<sup>2</sup>/l - Per confezione (15 l): 150 m<sup>2</sup> <b>Colore:</b> incolore e colorato</p>		<p><b>Equipment:</b> brush, roller, airless <b>Dilution:</b> Diluente Sintetico - 5-10% <b>Coverage</b> (1 coat): 9-11 m<sup>2</sup>/l - Per packaging (15 l): 150 m<sup>2</sup> <b>Color:</b> colourless and colored</p>		<p><b>Herramientas:</b> brocha, rodillo, pistola pulverizadora <b>Dilución:</b> Diluente Sintetico - 5-10% <b>Rendimiento</b> (1 capa): 9-11 m<sup>2</sup>/l - Por envase (15 l): 150 m<sup>2</sup> <b>Color:</b> incolore y colorido</p>	

tecniche	certificazioni	proprietà	tecnologie
SOLVENT BASED BRUSH ROLLER AIRLESS		matt BRILLIANCE	

## idroflatting



scheda  
tecnica



data  
sheet



ficha  
técnica



finitura per legno all'acqua	interno esterno	water-based finish for wood	indoor outdoor	acabado para madera al agua	interior exterior
Vernice trasparente lucida, di elevato pregio e brillantezza. Garantisce la protezione del supporto dai raggi ultravioletti. Formulata per il trattamento di manufatti lignei situati all'esterno. Per uso professionale.		Glossy, transparent varnish of high quality and gloss. Ensure protection against ultraviolet light. Formulated to treat wood located outdoors. For professional use.		Pintura transparente brillante a base de resinas acrílicas, de alta calidad y brillo. Garantizar la protección del soporte contra los rayos ultravioleta. Formulado para el tratamiento de elementos de madera situados en el exterior. Para uso profesional.	
<b>Attrezzatura:</b> pennello, rullo, spruzzo <b>Diluizione:</b> acqua - a pennello e rullo 5-10% a spruzzo 10/15%		<b>Equipment:</b> brush, roller, airless <b>Dilution:</b> water - a brush e roller 5-10% a airless 10/15%		<b>Herramientas:</b> brocha, rodillo, pistola pulverizadora <b>Dilución:</b> Diluyente Sintetico - 5-15%	
<b>Resa</b> (1 mano): 7-8 m <sup>2</sup> /l - Per confezione (15 l): 120 m <sup>2</sup> <b>Colore:</b> incolore		<b>Coverage</b> (1 coat): 7-8 m <sup>2</sup> /l - Per packaging (15 l): 120 m <sup>2</sup> <b>Color:</b> colourless		<b>Rendimento</b> (1 capa): 7-8 m <sup>2</sup> /l - Por envase (15 l): 120 m <sup>2</sup> <b>Color:</b> incoloro	

tecniche				certificazioni				proprietà				tecnologie				
WATER BASED	BRUSH	ROLLER	AIRLESS					gloss								
								BRILLIANCE								

## idroflatting opaco



scheda  
tecnica



data  
sheet



ficha  
técnica



finitura per legno all'acqua opaca	interno esterno	waterborne matt finish for wood	indoor outdoor	acabado para madera al agua opaca	interior exterior
Vernice di elevato pregio. Garantisce la protezione del supporto dai raggi ultravioletti. Formulata per il trattamento di manufatti lignei situati all'esterno. Per uso professionale.		Transparent acrylic resin-based varnish, high quality and gloss finish. Ensure protection against ultraviolet light (greying, discolouration). Formulated to treat wood located outdoors. For professional use.		Pintura de alta calidad y brillo. Garantizar la protección del soporte contra los rayos ultravioleta (agrisamiento, decoloración). Formulado para el tratamiento de elementos de madera situados en el exterior. Para uso profesional.	
<b>Attrezzatura:</b> pennello, rullo, spruzzo <b>Diluizione:</b> acqua - a pennello e rullo 5-10% a spruzzo 10/15%		<b>Equipment:</b> brush, roller, airless <b>Dilution:</b> water - a brush e roller 5-10% a airless 10/15%		<b>Herramientas:</b> brocha, rodillo, pistola pulverizadora <b>Dilución:</b> Diluyente Sintetico - 5-15%	
<b>Resa</b> (1 mano): 7-8 m <sup>2</sup> /l - Per confezione (15 l): 120 m <sup>2</sup> <b>Colore:</b> incolore		<b>Coverage</b> (1 coat): 7-8 m <sup>2</sup> /l - Per packaging (15 l): 120 m <sup>2</sup> <b>Color:</b> colourless		<b>Rendimento</b> (1 capa): 7-8 m <sup>2</sup> /l - Por envase (15 l): 120 m <sup>2</sup> <b>Color:</b> incoloro	

tecniche				certificazioni				proprietà				tecnologie				
WATER BASED	BRUSH	ROLLER	AIRLESS					matt								
								BRILLIANCE								

## idrofill



scheda  
tecnica



data  
sheet



ficha  
técnica



impregnante per legno all'acqua	<b>interno esterno</b>	water-based impregnating agent for wood	<b>indoor outdoor</b>	protector de la madera	<b>interior exterior</b>
<p>Protettivo del legno. Forma un film estremamente sottile ma fortemente resistente agli attacchi di agenti fisici esterni ed alle muffe. Penetra in profondità, non creando una pellicola superficiale evita il problema dello sfogliamento. Opaco. Per uso professionale.</p>		<p>Protective product for wood. It forms a film that is extremely thin and yet highly water-repellent, resistant to external physical agents and mould. It penetrates in depth, does not form a film and thus does not peel. Odourless when dry. Matt. For professional use.</p>		<p>Protector de la madera. Forma una película extremadamente fina pero de gran resistencia a los ataques de agentes físicos externos y a los mohos. Penetra en profundidad sin actuar como película, por lo cual no se exfolia, una vez seco no tiene olor. Mate. Para uso profesional.</p>	
<p><b>Attrezzatura:</b> pennello, rullo, spruzzo <b>Diluizione:</b> pronto all'uso <b>Resa</b> (1 mano): 10-12 m<sup>2</sup>/l - Per confezione (15 l): 165 m<sup>2</sup> <b>Colore:</b> incolore e colorato</p>		<p><b>Equipment:</b> brush, roller, airless <b>Dilution:</b> ready to use <b>Coverage</b> (1 coat): 10-12 m<sup>2</sup>/l - Per packaging (15 l): 165 m<sup>2</sup> <b>Color:</b> colourless and colored</p>		<p><b>Herramientas:</b> brocha, rodillo, pistola pulverizadora <b>Dilución:</b> listo para usar <b>Rendimiento</b> (1 capa): 10-12 m<sup>2</sup>/l - Por envase (15 l): 165 m<sup>2</sup> <b>Color:</b> incoloro y colorido</p>	

tecniche	certificazioni	proprietà	tecnologie
WATER BASED BRUSH ROLLER AIRLESS READY TO USE		matt BRILLIANCE	

## idrocerato



scheda  
tecnica



data  
sheet



ficha  
técnica



impregnante per legno all'acqua cerato	<b>interno esterno</b>	water-based Wax product, impregnating agent for wood	<b>indoor outdoor</b>	protector hidro-repelente para la madera	<b>interior exterior</b>
<p>Protettivo del legno a base di resine acriliche e cera, idrorepellente. Forma un film estremamente sottile ma fortemente resistente agli attacchi di agenti fisici esterni ed alle muffe. Penetra in profondità e rende il legno estremamente idrorepellente, è privo di odore. Opaco. Per uso professionale.</p>		<p>Combination chlorinated rubber resin-based enamel containing weather-resistant pigments. Specially formulated to paint swimming pools. For outdoor use. For professional use.</p>		<p>Protector hidro-repelente para la madera, a base de resinas acrilicas y cera. Forma una película extremadamente fina pero de gran resistencia a los ataques de agentes físicos externos y mohos. Penetra en profundidad y dota a la madera de una extrema calidad hidro-repelente, no desprende olor. Mate. Para uso profesional.</p>	
<p><b>Attrezzatura:</b> pennello, rullo, spruzzo <b>Diluizione:</b> pronto all'uso <b>Resa</b> (1 mano): 9-10 m<sup>2</sup>/l - Per confezione (15 l): 140 m<sup>2</sup> <b>Colore:</b> incolore e colorato</p>		<p><b>Equipment:</b> brush, roller, airless <b>Dilution:</b> ready to use <b>Coverage</b> (1 coat): 9-10 m<sup>2</sup>/l - Per packaging (15 l): 140 m<sup>2</sup> <b>Color:</b> colourless and colored</p>		<p><b>Herramientas:</b> brocha, rodillo, pistola pulverizadora <b>Dilución:</b> listo para usar <b>Rendimiento</b> (1 capa): 9-10 m<sup>2</sup>/l - Por envase (15 l): 140 m<sup>2</sup> <b>Color:</b> incoloro y colorido</p>	

tecniche	certificazioni	proprietà	tecnologie
WATER BASED BRUSH ROLLER AIRLESS READY TO USE		matt BRILLIANCE	

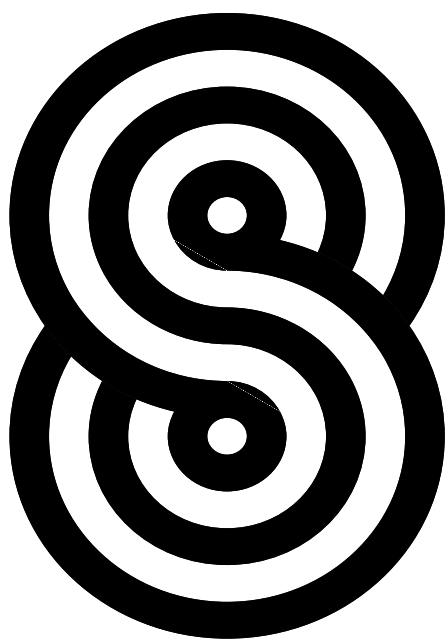

**termok8<sup>®</sup>**

# ISOL AMME NITO TER MICO





# termok

finiture per cappotto Leeder in Italia

# linee prodotti

collanti e rasanti

collanti e rasanti ht

collanti-fuganti TermoK8 modular

isolanti

tasselli ht

tasselli

accessori ht

accessori

elementi di fissaggio

davanzali

reti in fibra di vetro

finiture

rivestimenti modulari

decori e cornici

attezzature

# 8

## klebocem



scheda  
tecnica



data  
sheet



ficha  
técnica



collante/rasante in polvere	interno esterno	adhesive/skim coat in powder form	indoor outdoor	cola/mortero de enrasado en polvo	interior exterior
Adesivo/rasante minerale eco-compatibile in polvere a base di resine insaponificabili, Cemento Portland ad alta resistenza e sabbie selezionate granulometria max 0,6mm. Specifico per l'incollaggio e la rasatura di pannelli isolanti nei cicli Termok8 <sup>®</sup> e per ciclo armato Rasoprotection. Per uso professionale.		Eco-friendly mineral adhesive/skim coat in powder form made of unsaponifiable resins, high-resistance Portland cement and selected sands with a maximum particle size of 0.6 mm. Specifically formulated for gluing and skimming of insulating panels in Termok8 <sup>®</sup> processes and Rasoprotection reinforced process. For professional use.		Adesivo/mortero de enrasado eco-compatibile en polvo a base de resinas insaponificables, Cemento Portland de alta resistencia y arenas seleccionadas granulometria máx 0,6 mm. Especifico para el encolado y enrasado de paneles aislantes en los ciclos Termok8 <sup>®</sup> y para ciclo armado Rasoprotection. Para uso profesional.	
<b>Granulometria:</b> 0,6 mm <b>Attrezzatura:</b> spatola, cazzuola, frattazzo di spugna, impastatrice a basso numero di giri <b>Rapporto di miscelazione:</b> acqua - 22-24% <b>Consumo:</b> 1,3 kg/m <sup>2</sup> per mm di spessore; per incollare 4-4,5 kg/m <sup>2</sup> - per rasare 4-4,5 kg/m <sup>2</sup>		<b>Particle size:</b> 0.6 mm <b>Equipment:</b> spatula, mason's trowel, sponge trowel, low speed mixer <b>Mixing ratio:</b> water - 22-24%. <b>Recommended use:</b> 1.3 kg/m <sup>2</sup> per mm of thickness; for gluing 4-4.5 kg/m <sup>2</sup> - for skimming 4-4.5 kg/m <sup>2</sup>		<b>Granulometria:</b> 0,6 mm <b>Herramientas:</b> espátula, paleta, llana de esponja, amasadora de bajo número de revoluciones <b>Relación de mezcla:</b> agua - 22-24 % <b>Consumo:</b> 1,3 kg/m <sup>2</sup> por mm de espesor; para encolar 4-4,5 kg/m <sup>2</sup> - para enrasar 4-4,5 kg/m <sup>2</sup>	

tecniche	certificazioni	proprietà	tecnologie
WATER BASED TROWEL			

## klebocem grosso



scheda  
tecnica



data  
sheet



ficha  
técnica



collante/rasante in polvere	interno esterno	adhesive/skim coat in powder form	indoor outdoor	cola/mortero de enrasado en polvo	interior exterior
Adesivo/rasante minerale eco-compatibile in polvere a base di resine insaponificabili, Cemento Portland ad alta resistenza e sabbie selezionate, granulometria max 1,2mm. Specifico per la rasatura di pannelli isolanti nei cicli Termok8 <sup>®</sup> quando è necessario ottenere spessori elevati con l'uso di rete Armatex C1 M o C1 R. Per uso professionale.		Eco-friendly mineral adhesive/skim coat in powder form made of unsaponifiable resins, high-resistance Portland cement and selected sands, maximum particle size of 1.2mm. Specifically formulated for skimming insulating panels used in Termok8 <sup>®</sup> processes when high thicknesses need to be obtained using an Armatex C1 M or C1 R mesh. For professional use.		Adesivo/mortero de enrasado eco-compatibile en polvo a base de resinas insaponificables, Cemento Portland de alta resistencia y arenas seleccionadas, granulometria máx. 1,2 mm. Especifico para el enrasado de paneles aislantes en los ciclos Termok8 <sup>®</sup> cuando es necesario obtener espesores altos con el uso de malla Armatex C1 M o C1 R. Para uso profesional.	
<b>Granulometria:</b> 1,2 mm <b>Attrezzatura:</b> spatola, cazzuola, frattazzo di spugna, impastatrice a basso numero di giri <b>Rapporto di miscelazione:</b> acqua - 22-24% <b>Consumo:</b> 1,3 kg/m <sup>2</sup> per mm di spessore; per incollare 4-4,5 kg/m <sup>2</sup> - per rasare 4-4,5 kg/m <sup>2</sup>		<b>Particle size:</b> 1.2 mm <b>Equipment:</b> spatula, mason's trowel, sponge trowel, low speed mixer <b>Mixing ratio:</b> water - 22-24%. <b>Recommended use:</b> 1.3 kg/m <sup>2</sup> per mm of thickness; for gluing 4-4.5 kg/m <sup>2</sup> - for skimming 4-4.5 kg/m <sup>2</sup>		<b>Granulometria:</b> 1,2 mm <b>Herramientas:</b> espátula, paleta, llana de esponja, amasadora de bajo número de revoluciones <b>Relación de mezcla:</b> agua - 22-24 % <b>Consumo:</b> 1,3 kg/m <sup>2</sup> por mm de espesor; para encolar 4-4,5 kg/m <sup>2</sup> - para enrasar 4-4,5 kg/m <sup>2</sup>	

tecniche	certificazioni	proprietà	tecnologie
WATER BASED TROWEL			

## adefix 12 grigio



scheda  
tecnica



data  
sheet



ficha  
técnica



collante/rasante in polvere	interno esterno	adhesive/skim coat in powder form	indoor outdoor	cola/mortero de enrasado en polvo	interior exterior
Adesivo/rasante minerale eco-compatibile in polvere dotato di ottime caratteristiche adesivanti e resistenza ai cicli di gelo e disgelo. A base di resine insaponificabili, Cemento Portland ad alta resistenza e sabbie selezionate. Ottima spatolabilità e riempimento, idoneo per incollaggio, rasature anche armate con rete di rinforzo, su intonaci cavillati, cemento armato, pannelli isolanti. Per uso professionale.		Eco-friendly mineral adhesive/skim coat in powder form with superb adhesive properties and resistance to freeze-thaw cycles. Made of unsaponifiable resins, high resistance Portland cement and selected sands. Superb filling capacity and trowel applicability. Suitable for gluing, skim coats (even mesh-reinforced), cracked plaster, reinforced concrete, insulating panels. For professional use.		Adhesivo/rasante mineral eco-compatibile en polvo dotado de óptimas características adhesivas y resistencia a los ciclos de congelación y deshielo. A base de resinas insaponificables, Cemento Portland de alta resistencia y arena seleccionadas. Óptima spatolabilidad y llenado, idóneo para encolado, rasaduras también armadas con red de refuerzo, sobre enlucidos cavilados, hormigón armado, paneles aislantes. Para uso profesional.	
<b>Granulometria:</b> 0,8 mm, (Adefix 12 Grigio Grosso: 1,2 mm) <b>Attrezzatura:</b> spatola, cazzuola, frattazzo di spugna, impastatrice a basso numero di giri <b>Rapporto di miscelazione:</b> acqua - 22-24% <b>Consumo:</b> 1,3 kg/m <sup>2</sup> per mm di spessore; Per Incollare: 4-4,5 kg/m <sup>2</sup> - Per Rasare: 4-4,5 kg/m <sup>2</sup>		<b>Particle size:</b> 0.8 mm, (Adefix 12 Grey Coarse: 1.2 mm) <b>Equipment:</b> spatula, mason's trowel, sponge trowel, low speed mixer <b>Mixing ratio:</b> water - 22-24%. <b>Recommended use:</b> 1.3 kg/m <sup>2</sup> per mm of thickness; For gluing: 4-4.5 kg/m <sup>2</sup> - For Skimming: 4-4.5 kg/m <sup>2</sup>		<b>Granulometría:</b> 0,8 mm, (Adefix 12 Gris Grueso: 1,2 mm) <b>Herramientas:</b> espátula, paleta, llana de esponja, amasadora de bajo número de revoluciones <b>Relación de mezcla:</b> agua - 22-24 % <b>Consumo:</b> 1,3 kg/m <sup>2</sup> por mm de espesor; Para encolar: 4-4,5 kg/m <sup>2</sup> - Para enrasar: 4-4,5 kg/m <sup>2</sup>	

tecniche	certificazioni	proprietà	tecnologie
WATER BASED TROWEL			

## adefix 12 bianco



scheda  
tecnica



data  
sheet



ficha  
técnica



collante/rasante in polvere bianco	interno esterno	white adhesive/skim coat in powder form	indoor outdoor	cola/mortero de enrasado en polvo blanco	interior exterior
Adesivo/rasante minerale eco-compatibile in polvere dotato di ottime caratteristiche adesivanti e resistenza ai cicli di gelo e disgelo. A base di resine insaponificabili, Cemento Bianco ad alta resistenza e sabbie selezionate. Ottima spatolabilità e riempimento, idoneo per incollaggio, rasature anche armate con rete di rinforzo, su intonaci cavillati, cemento armato, pannelli isolanti. Per uso professionale.		Eco-friendly mineral adhesive/skim coat in powder form with superb adhesive properties and resistance to freeze-thaw cycles. Made of unsaponifiable resins, high resistance White Cement and selected sands. Superb filling capacity and trowel applicability. Suitable for gluing, skim coats (even mesh-reinforced), cracked plaster, reinforced concrete, insulating panels. For professional use.		Adhesivo/rasante mineral eco-compatibile en polvo dotado de óptimas características adhesivas y resistencia a los ciclos de congelación y deshielo. A base de resinas insaponificables, Cemento Blanco de alta resistencia y arenas seleccionadas. Óptima spatolabilidad y llenado, idóneo para encolado, rasaduras también armadas con red de refuerzo, sobre enlucidos cavilados, hormigón armado, paneles aislantes. Para uso profesional.	
<b>Granulometria:</b> 0,8 mm (Adefix 12 Bianco Grosso: 1,2 mm) <b>Attrezzatura:</b> spatola, cazzuola, frattazzo di spugna, impastatrice a basso numero di giri <b>Rapporto di miscelazione:</b> acqua - 22-24% <b>Consumo:</b> 1,3 kg/m <sup>2</sup> per mm di spessore; Per Incollare: 4-4,5 kg/m <sup>2</sup> - Per Rasare: 4-4,5 kg/m <sup>2</sup>		<b>Particle size:</b> 0.8 mm (Adefix 12 white coarse: 1.2 mm) <b>Equipment:</b> spatula, mason's trowel, sponge trowel, low speed mixer <b>Mixing ratio:</b> water - 22-24%. <b>Recommended use:</b> 1.3 kg/m <sup>2</sup> per mm of thickness; For gluing: 4-4.5 kg/m <sup>2</sup> - For Skimming: 4-4.5 kg/m <sup>2</sup>		<b>Granulometría:</b> 0,8 mm (Adefix 12 Blanco Grueso: 1,2 mm) <b>Herramientas:</b> espátula, paleta, llana de esponja, amasadora de bajo número de revoluciones <b>Relación de mezcla:</b> agua - 22-24 % <b>Consumo:</b> 1,3 kg/m <sup>2</sup> por mm de espesor; Para encolar: 4-4,5 kg/m <sup>2</sup> - Para enrasar: 4-4,5 kg/m <sup>2</sup>	

tecniche	certificazioni	proprietà	tecnologie
WATER BASED TROWEL			

## Iecocem 100

scheda  
tecnicadata  
sheetficha  
técnica

collante/rasante plastico in pasta	esterno	plastic adhesive/skim coat in paste form	outdoor	cola/mortero de enrasado plástico en pasta	exterior
<p>Collante/rasante plastico in pasta specifico per polistirene espanso estruso, fibre minerali e lana di vetro. A base di resine in dispersione insaponificabili e sabbie selezionate, dotato di ottime caratteristiche adesivanti, idoneo per rasature armate con rete di rinforzo su intonaci cavillati, cemento, polistirolo espanso ed estruso, lana di vetro e quale collante per lastre di polistirolo in genere e in fibre minerali per Termok8<sup>®</sup>. Per uso professionale.</p>		<p>Plastic adhesive/skim coat in paste form, specific for extruded polystyrene foam, mineral fibres and glass fibres. Based on unsaponifiable resins in dispersion and selected sands, provides excellent adhesive properties. Ideal for mesh-reinforced skim coats on cracked plasters, cement, extruded polystyrene foam, glass fibre and as an adhesive for sheets of polystyrene in general and mineral fibres for Termok8<sup>®</sup> system. For professional use.</p>		<p>Cola/mortero de enrasado plástico en pasta específico para poliestireno expandido extruido, fibras minerales y lana de vidrio. A base de resinas insaponificables en dispersión y arenas seleccionadas, dotado de excelentes características de adhesión, idóneo para enrasados armados con malla de refuerzo sobre enfoscados cuarteados, cemento, poliestireno expandido y extruido, lana de vidrio, y como cola para placas de poliestireno en general y en fibras minerales para Termok8<sup>®</sup>. Para uso profesional.</p>	
<p><b>Granulometria:</b> &lt;0,5 mm <b>Attrezzatura:</b> spatola, cazzuola, impastatrice a basso numero di giri <b>Rapporto di miscelazione:</b> Cemento PTL 325 - 100% <b>Consumo:</b> 1,3 kg/m<sup>2</sup> per mm di spessore; Per Incollare: 4-4,5 kg/m<sup>2</sup> - Per Rasare: 4-4,5 kg/m<sup>2</sup></p>		<p><b>Particle size:</b> &lt;0.5 mm <b>Equipment:</b> spatula, mason's trowel, low speed mixer. <b>Mixing ratio:</b> PTL cement 325 - 100% <b>Recommended use:</b> 1.3 kg/m<sup>2</sup> per mm of thickness; For gluing: 4-4.5 kg/m<sup>2</sup> - For Skimming: 4-4.5 kg/m<sup>2</sup></p>		<p><b>Granulometría:</b> &lt;0,5 mm <b>Herramientas:</b> espátula, paleta, amasadora de bajo número de revoluciones <b>Relación de mezcla:</b> Cemento PTL 325 - 100 % <b>Consumo:</b> 1,3 kg/m<sup>2</sup> por mm de espesor; Para encolar: 4-4,5 kg/m<sup>2</sup> - Para enrasar: 4-4,5 kg/m<sup>2</sup></p>	

tecniche		certificazioni				proprietà				tecnologie			
													











## klebocem termico

scheda  
tecnicadata  
sheetficha  
técnica

collante/rasante termico in polvere	interno esterno	thermal adhesive/skim coat in powder form	indoor outdoor	cola/mortero de enrasado térmico en polvo	interior exterior
Adesivo/rasante minerale eco-compatibile ad elevata prestazione termica con ottime caratteristiche adesivanti e di resistenza ai cicli di gelo e disgelo. Collante/rasante in polvere alleggerito con sfere di vetro cavo a base di Cemento Portland ad alta resistenza, sabbie selezionate e resine insaponificabili. Idoneo per l'incollaggio di pannelli isolanti nei cicli Termok8 <sup>®</sup> , per rasature, rasature armate con rete di rinforzo, su intonaci cavillati, cemento armato. Per uso professionale.		Eco-friendly mineral adhesive/skim coat in powder form with high thermal performance, superb adhesive properties and resistance to freeze-thaw cycles. Adhesive/skim coat in powder form made of high resistance Portland cement, lightened with hollow glass beads, selected sands and unsaponifiable resins. Suitable for gluing insulating panels in Termok8 <sup>®</sup> processes, for skimming, applying mesh-reinforced skim coats on cracked plaster, reinforced concrete. For professional use.		Adhesivo/mortero de enrasado mineral eco-compatibile de altas prestaciones térmicas con excelentes características de adhesión y resistencia a los ciclos de hielo y deshielo. Cola/mortero de enrasado en polvo aligerado con esferas de vidrio hueco, a base de Cemento Portland de alta resistencia, arenas seleccionadas y resinas insaponificables. Idóneo para el encolado de paneles aislantes en los ciclos Termok8 <sup>®</sup> , para enrasados, enrasados armados con malla de refuerzo, sobre enfoscados cuarteados, hormigón armado. Para uso profesional.	
<b>Granulometria:</b> 1 mm <b>Attrezzatura:</b> spatola, cazzuola, frattazzo di spugna, impastatrice a basso numero di giri <b>Rapporto di miscelazione:</b> acqua - 31/32% <b>Consumo:</b> 0,9 kg/m <sup>2</sup> per mm di spessore; Per Incollare: 2,7-3,2 kg/m <sup>2</sup> - Per Rasare: 2,7-3,2 kg/m <sup>2</sup>		<b>Particle Size:</b> 1 mm <b>Equipment:</b> spatula, mason's trowel, sponge trowel, low speed mixer <b>Mixing ratio:</b> water - 31/32% <b>Recommended use:</b> 0.9 kg/m <sup>2</sup> per mm of thickness; For gluing: 2.7-3.2 kg/m <sup>2</sup> - For Skimming: 2.7-3.2 kg/m <sup>2</sup>		<b>Granulometría:</b> 1 mm <b>Herramientas:</b> espátula, paleta, llana de esponja, amasadora de bajo número de revoluciones <b>Relación de mezcla:</b> agua - 31/32% <b>Consumo:</b> 0,9 kg/m <sup>2</sup> por mm de espesor; Para encolar: 2,7-3,2 kg/m <sup>2</sup> - Para enrasar: 2,7-3,2 kg/m <sup>2</sup>	

tecniche	certificazioni	proprietà	tecnologie
 WATER BASED  TROWEL			

## klebocem fibrato

scheda  
tecnicadata  
sheetficha  
técnica

collante/rasante fibrorinforzato	interno esterno	fibre-reinforced adhesive/skim coat	indoor outdoor	cola/mortero de enrasado fibrorreforzado	interior exterior
Adesivo/rasante minerale eco-compatibile in polvere additivato con fibre poliammidiche, con ottime caratteristiche adesivanti e resistenza ai cicli di gelo e disgelo. Particolarmente indicato per rasature armate su intonaci cavillati e cemento armato. Idoneo anche come rasante nei cicli Termok8. Prodotto verificato secondo le norme UNI EN 998-1 per l'uso del marchio CE. Per uso professionale.		Eco-friendly mineral adhesive/skim coat in powder form with the addition of polyamide fibres. Superb adhesive properties and resistance to freeze-thaw cycles. Particularly suitable for reinforced skim coats applied on cracked plaster and reinforced concrete. Also suitable as skim coat For the Termok8 processes. Product tested according to UNI EN 998-1 for use of CE marking. For professional use.		Adhesivo/mortero de enrasado mineral eco-compatibile en polvo con aditivo de fibras poliamidicas, dotado de excelentes características de adhesión y resistencia a los ciclos de hielo y deshielo. Particularmente indicado para enrasados armados sobre enfoscados cuarteados y hormigón armado. Idóneo también como mortero de enrasado en los ciclos Termok8. Producto verificado conforme a las normas UNI EN 998-1 para el uso de la marca CE. Para uso profesional.	
<b>Granulometria:</b> max 0,6 mm <b>Attrezzatura:</b> spatola, cazzuola, frattazzo di spugna, impastatrice a basso numero di giri <b>Rapporto di miscelazione:</b> acqua - 22-24% <b>Consumo:</b> 1,3 kg/m <sup>2</sup> per mm di spessore; Per Incollare: 4-4,5 kg/m <sup>2</sup> - Per Rasare: 4-4,5 kg/m <sup>2</sup>		<b>Particle Size:</b> max 0.6 mm <b>Equipment:</b> spatula, mason's trowel, sponge trowel, low speed mixer <b>Mixing ratio:</b> water - 22-24% <b>Recommended use:</b> 1.3 kg/m <sup>2</sup> per mm of thickness; For gluing: 4-4.5 kg/m <sup>2</sup> - For Skimming: 4-4.5 kg/m <sup>2</sup>		<b>Granulometría:</b> máx. 0,6 mm <b>Herramientas:</b> espátula, paleta, llana de esponja, amasadora de bajo número de revoluciones <b>Relación de mezcla:</b> agua - 22-24% <b>Consumo:</b> 1,3 kg/m <sup>2</sup> por mm de espesor; Para encolar: 4-4,5 kg/m <sup>2</sup> - Para enrasar: 4-4,5 kg/m <sup>2</sup>	

tecniche	certificazioni	proprietà	tecnologie
 WATER BASED  TROWEL			

## klebocem ultra



scheda  
tecnica



data  
sheet



ficha  
técnica



collante/rasante per Termok8 Modulari	interno esterno	adhesive/skim coat for Termok8 modular systems	indoor outdoor	cola/mortero de enrasado para Termok8 Modulares	interior exterior
<p>Adesivo/rasante minerale eco-compatibile ad adesione migliorata a base di resine insaponificabili, Cemento Portland ad alta resistenza e sabbie selezionate. Possiede ottime caratteristiche adesivanti e resistenza ai cicli di gelo e disgelo. Idoneo per incollare e rasare i pannelli isolanti tipo FIX per Termok8 Modulari. Per uso professionale.</p>		<p>Eco-friendly mineral adhesive/skim coat with adhesion properties boosted by the use of unsaponifiable resins, high-resistance Portland cement and selected sands. It offers superb adhesive properties and resistance to freeze-thaw cycles. Suitable for gluing and skimming FIX-type insulating panels For the Termok8: modular systems. For professional use.</p>		<p>Adhesivo/mortero de enrasado mineral eco-compatibile de adhesión mejorada a base de resinas insaponificables, Cemento Portland de alta resistencia y arenas seleccionadas. Posee excelentes características de adhesión y resistencia a los ciclos de hielo y deshielo. Idóneo para encolar y enrasar paneles aislantes tipo FIX para Termok8 Modulares. Para uso profesional.</p>	
<p><b>Granulometria:</b> max 0,8 mm <b>Attrezzatura:</b> spatola, cazzuola, frattazzo di spugna, impastatrice a basso numero di giri <b>Rapporto di miscelazione:</b> acqua - 22-24% <b>Consumo:</b> 1,3 kg/m<sup>2</sup> per mm di spessore; Per Incollare: 4-4,5 kg/m<sup>2</sup> - Per Rasare: 4-4,5 kg/m<sup>2</sup></p>		<p><b>Particle Size:</b> max 0.8 mm <b>Equipment:</b> spatula, mason's trowel, sponge trowel, low speed mixer <b>Mixing ratio:</b> water - 22-24%. <b>Recommended use:</b> 1.3 kg/m<sup>2</sup> per mm of thickness; For gluing: 4-4.5 kg/m<sup>2</sup> - For Skimming: 4-4.5 kg/m<sup>2</sup></p>		<p><b>Granulometría:</b> máx. 0,8 mm <b>Herramientas:</b> espátula, paleta, llana de esponja, amasadora de bajo número de revoluciones <b>Relación de mezcla :</b> agua - 22-24 % <b>Consumo:</b> 1,3 kg/m<sup>2</sup> por mm de espesor; Para encolar: 4-4,5 kg/m<sup>2</sup> - Para enrasar: 4-4,5 kg/m<sup>2</sup></p>	

tecniche	certificazioni	proprietà	tecnologie
WATER BASED TROWEL			

## klebocem R 110 J



scheda  
tecnica



data  
sheet



ficha  
técnica



collante/rasante ad elevate resistenze agli urti	interno esterno	high impact resistance adhesive/skim coat	indoor outdoor	cola/mortero de enrasado de alta resistencia a los golpes	interior exterior
<p>Collante e rasante fibrato addizionato con materie prime termoplastiche ideale come rasante per ciclo Termok8 AR Max 60 J e per cicli di isolamento a cappotto con resistenze all'urto fino a 110 J. Prodotto verificato secondo le norme UNI EN 998-1 ( tipo LW CS III W 2 ) per l'uso del marchio CE. Per uso professionale.</p>		<p>Fibre-based adhesive/skim coat with added thermoplastic raw materials, ideal as skimming plaster For the Termok8: AR Max 60 J systems and for thermal insulation processes with impact resistance rated up to 110 J. Product tested according to UNI EN 998-1 (type LW CS III W 2 ) for use of CE marking. For professional use.</p>		<p>Cola y mortero de enrasado fibrado, con materias primas termoplásticas añadidas, ideal como mortero de enrasado para ciclo Termok8 AR Max 60 J y para ciclos de aislamiento por capas con resistencias al impacto de hasta 110 J. Producto verificado según las normas UNI EN 998-1 (tipo LW CS III W 2) para el uso de la marca CE. Para uso profesional.</p>	
<p><b>Granulometria:</b> max 1 mm <b>Attrezzatura:</b> spatola, cazzuola, frattazzo di spugna, impastatrice a basso numero di giri <b>Rapporto di miscelazione:</b> acqua - 34-36% <b>Consumo:</b> 0,6 Kg/m<sup>2</sup> per mm di spessore; Per Rasare: 5-5,5 Kg/m<sup>2</sup> su lastra zigrinata</p>		<p><b>Particle Size:</b> max 1 mm <b>Equipment:</b> spatula, mason's trowel, sponge trowel, low speed mixer <b>Mixing ratio:</b> water - 34-36%. <b>Recommended use:</b> 0.6 Kg/m<sup>2</sup> per mm of thickness; For Skimming: 5- 5.5 Kg/m<sup>2</sup> on corrugated sheet</p>		<p><b>Granulometría:</b> máx. 1 mm <b>Herramientas:</b> espátula, paleta, llana de esponja, amasadora de bajo número de revoluciones <b>Relación de mezcla :</b> agua - 34-36% <b>Consumo:</b> 0,6 Kg/m<sup>2</sup> por mm de espesor; Para enrasar: 5-5,5 Kg/m<sup>2</sup> sobre placa moleteada</p>	

tecniche	certificazioni	proprietà	tecnologie
WATER BASED TROWEL			

## klebocem minerale

scheda  
tecnicadata  
sheetficha  
técnica

collante/rasante per termok8 minerali	interno esterno	adhesive/skim coat for mineral termok8 systems	indoor outdoor	cola/mortero de enrasado para termok8 minerales	interior exterior
Adesivo/rasante minerale eco-compatibile in polvere particolarmente indicato nei rivestimenti a cappotto di tipo minerale e per isolanti bio-compatibili. Specifico per l'incollaggio di pannelli isolanti naturali o minerali (sughero, lana di roccia, lana di vetro, ecc.) utilizzabile anche su pannelli in EPS bianco o grigio nei cicli Termok8®. Per uso professionale.		Eco-friendly mineral adhesive/skim coat in powder form particularly suitable for mineral-based external thermal insulation systems and eco-compatible insulation. Specific for gluing natural or mineral insulating panels (cork, rock wool, glass fibre, etc.). Can also be used on white or grey EPS panels in the Termok8® processes. For professional use.		Adhesivo/mortero de enrasado mineral eco-compatibile en polvo particularmente indicado para revestimientos por capas de tipo mineral y para aislantes bio-compatibles. Especifico para el encolado de paneles aislantes naturales o minerales (corcho, lana de roca, lana de vidrio, etc.), utilizable también con paneles de EPS blanco o gris en los ciclos Termok8®. Para uso profesional.	
<b>Granulometria:</b> max 0,6 mm <b>Attrezzatura:</b> spatola, cazzuola, frattazzo di spugna, impastatrice a basso numero di giri <b>Rapporto di miscelazione:</b> acqua - 22-24% <b>Consumo:</b> 1,3 kg/m <sup>2</sup> per mm di spessore; Per Incollare: 4-4,5 kg/m <sup>2</sup> - Per Rasare: 4-4,5 kg/m <sup>2</sup>		<b>Particle Size:</b> max 0.6 mm <b>Equipment:</b> spatula, mason's trowel, sponge trowel, low speed mixer <b>Mixing ratio:</b> water - 22-24%. <b>Recommended use:</b> 1.3 kg/m <sup>2</sup> per mm of thickness; For gluing: 4-4.5 kg/m <sup>2</sup> - For Skimming: 4-4.5 kg/m <sup>2</sup>		<b>Granulometria:</b> máx. 0,6 mm <b>Herramientas:</b> espátula, paleta, llana de esponja, amasadora de bajo número de revoluciones <b>Relación de mezcla:</b> agua - 22-24 % <b>Consumo:</b> 1,3 kg/m <sup>2</sup> por mm de espesor; Para encolar: 4-4,5 kg/m <sup>2</sup> - Para enrasar: 4-4,5 kg/m <sup>2</sup>	

tecniche	certificazioni	proprietà	tecnologie
 WATER BASED  TROWEL	 CE EN 998-1 GPCSIV  EPD		

## klebocalce naturale

scheda  
tecnicadata  
sheetficha  
técnica

collante/rasante a base di calce idraulica	interno esterno	hydraulic lime-based adhesive/skim coat	indoor outdoor	cola/mortero de enrasado a base de cal hidráulica	interior exterior
Collante/rasante a base di Calce Idraulica specifico per l'incollaggio e la rasatura di pannelli isolanti naturali o minerali nei cicli Termok8. Il prodotto unisce la lavorabilità e traspirabilità della Calce Idraulica Naturale (Natural Hydraulic Lime 3.5, UNI-EN 459-1_2010), a quelle di forza e rapidità di presa del Roman Cement (Ciment Prompt Naturel, NF P 15-314). Totalmente 'Portland Free', rappresenta la soluzione ideale per l'edilizia verde e il recupero architettonico. Per uso professionale.		Hydraulic lime-based adhesive/skim coat specifically designed for gluing and skimming natural or mineral insulating panels in Termok8 processes. The product blends the workability and breathability of Natural Hydraulic Lime (Natural Hydraulic Lime 3.5, UNI-EN 459-1_2010) with the fast setting properties of Roman Cement (Ciment Prompt Naturel, NF P 15-314). Totally 'Portland Free'. The ideal solution for green construction and architectural renovation. For professional use.		Cola/mortero de enrasado a base de cal hidráulica, específica para el encolado y el enrasado de paneles aislantes naturales o minerales en los ciclos Termok8. El producto une la facilidad de elaboración y transpirabilidad de la Cal Hidráulica Natural (Natural Hydraulic Lime 3.5, UNI-EN 459-1_2010), a las de fuerza y rapidez de fraguado del Roman Cement (Ciment Prompt Naturel, NF P 15-314). Totalmente 'Portland Free', representa la solución ideal para la construcción ecológica y la recuperación arquitectónica. Para uso profesional.	
<b>Granulometria:</b> max 0,6 mm <b>Attrezzatura:</b> spatola, cazzuola, frattazzo di spugna, impastatrice a basso numero di giri <b>Rapporto di miscelazione:</b> acqua - 30-32% <b>Consumo:</b> 1,1 kg/m <sup>2</sup> per mm di spessore; Per Incollare: 3,5-4 kg/m <sup>2</sup> - Per Rasare: 3,5-4 kg/m <sup>2</sup>		<b>Particle Size:</b> max 0.6 mm <b>Equipment:</b> spatula, mason's trowel, sponge trowel, low speed mixer <b>Mixing ratio:</b> water - 30-32%. <b>Recommended use:</b> 1.1 kg/m <sup>2</sup> per mm of thickness; For gluing: 3.5-4 kg/m <sup>2</sup> - For Skimming: 3.5-4 kg/m <sup>2</sup>		<b>Granulometria:</b> máx. 0,6 mm <b>Herramientas:</b> espátula, paleta, llana de esponja, amasadora de bajo número de revoluciones <b>Relación de mezcla:</b> agua - 30-32% <b>Consumo:</b> 1,1 kg/m <sup>2</sup> por mm de espesor; Para encolar: 3,5-4 kg/m <sup>2</sup> - Para enrasar: 3,5-4 kg/m <sup>2</sup>	

tecniche	certificazioni	proprietà	tecnologie
 WATER BASED  TROWEL	 CE EN 998-1 GPCSIIV		

## rasogum



scheda  
tecnica



data  
sheet



ficha  
técnica



rasante cementizio elastomerico	interno esterno	elastomeric cement-based skim coat	indoor outdoor	mortero de cemento elastomérico	interior exterior
Rasante plastico in pasta da additarsi con cemento PTL 325 a base di resine in dispersione insaponificabili e sabbie selezionate, dotato di ottime caratteristiche adesivanti, ottima spatolabilità e riempimento. L'aggiunta con resine elastomeriche lo rende idoneo per rasature anche armate con rete di rinforzo Armatex all'interno del ciclo Rasoprotection. Per uso professionale.		Plastic skim coat in paste form to which PTL 325 cement is to be added. Contains unsaponifiable resins in dispersion and selected sands. Offers excellent adhesion, filling capacity and trowel applicability properties. The addition of elastomeric resins makes it suitable for skimming, even when Armatex reinforcement mesh is used with the Rasoprotection process. For professional use.		Mortero de enrasado plástico en pasta, para aditar con cemento PTL 325 a base de resinas en dispersión insaponificables y arenas seleccionadas, dotado de excelentes características de adhesión, excelente facilidad para la extensión con espátula y para relleno. El aditivado con resinas elastoméricas lo hace idóneo para enrasados incluso armados con malla de refuerzo Armatex dentro del ciclo Rasoprotection. Para uso profesional.	
<b>Granulometria:</b> max 1 mm <b>Attrezzatura:</b> spatola, cazzuola, frattazzo di spugna, impastatrice a basso numero di giri <b>Rapporto di miscelazione:</b> 30% con cemento PTL 325 <b>Resa:</b> 1 kg/m <sup>2</sup> per mm di spessore; Per Rasare: 3-3,5 kg/m <sup>2</sup> <b>Colore:</b> grigio		<b>Particle Size:</b> max 1 mm <b>Equipment:</b> spatula, mason's trowel, sponge trowel, low speed mixer <b>Mixing ratio:</b> 30% with PTL 325 cement <b>Coverage:</b> 1Kg/ m <sup>2</sup> per mm of thickness; For skimming: 3-3.5 kg/m <sup>2</sup> <b>Color:</b> grey		<b>Granulometría:</b> máx. 1 mm <b>Herramientas:</b> espátula, paleta, llana de esponja, amasadora de bajo número de revoluciones <b>Relación de mezcla:</b> 30% con cemento PTL 325 <b>Rendimiento:</b> 1 kg/m <sup>2</sup> por mm de espesor; Para enrasar: 3-3,5 kg/m <sup>2</sup> <b>Color:</b> gris	

tecniche	certificazioni	proprietà	tecnologie
WATER BASED TROWEL			

## TermoK8 foam



scheda  
tecnica



data  
sheet



ficha  
técnica



schiuma adesiva poliuretanic	esterno	polyurethane adhesive foam	outdoor	espuma adhesiva poliuretánica	exterior
Adesivo in schiuma poliuretanic studiato per il fissaggio di pannelli di polistirolo espanso alle pareti esterne di edifici per l'isolamento termico, per davanzali. Caratterizzato da un'eccellente adesione su molti materiali come cemento, intonaco, mattoni, legno, metallo, polistirolo espanso XPS polistirolo ed estruso. Per uso professionale.		Polyurethane foam adhesive designed to secure expanded polystyrene panels to outside walls to achieve thermal building insulation, for window sills. It adheres well to many materials such as concrete, plaster, brick, wood, metal, polystyrene foam, XPS extruded polystyrene foam. For professional use.		Adhesivo en espuma poliuretánica studiado para la fijación de paneles de poliestireno expandido a las paredes externas de edificios para el aislamiento térmico; para alféizares. Se caracteriza por una excelente adhesión sobre muchos materiales como cemento, enfoscados, ladrillos, metal, poliestireno expandido XPS y poliestireno extruido. Para uso profesional.	
<b>Diluizione:</b> pronto all'uso <b>Confezione:</b> 1 scatola da 12 pezzi da 0,750 ml		<b>Dilution:</b> ready to use <b>Package:</b> 1 box da 12 pezzi da 0,750 ml		<b>Dilución:</b> listo para usar <b>Envase:</b> 1 caja de 12 piezas de 0,750 ml	

## sigil pol



scheda  
tecnica



data  
sheet



ficha  
técnica



sigillante elastico sovraverniciabile	flexible sealant that can be overpainted	sellador elástico, admite recubrimiento de pintura
Sigillante elastico Poliuretanic monocomponente igroindurente, sovraverniciabile.	One-pack, elastic, moisture-hardening polyurethane sealant. Can be overpainted.	Sellador elástico Poliuretanic monocomponente higroendurecible, admite recubrimiento de pintura.
<b>Applicazione:</b> estrusori pneumatici o manuali <b>Resa:</b> 100-150 g/m/cm <sup>2</sup>	<b>Application:</b> pneumatic or manual extruder <b>Coverage:</b> 100-150 g/m/cm <sup>2</sup>	<b>Aplicación:</b> extrusores neumáticos o manuales <b>Rendimiento:</b> 100-150 g/m <sup>2</sup>

## glueflex modular big grigio

 scheda  
tecnica

 data  
sheet

 ficha  
técnica

adesivo cementizio bicomponente grigio	interno esterno	two-pack cement-based adhesive - grey	indoor outdoor	adhesivo cementoso bicomponente gris	interior exterior
Adesivo cementizio bicomponente A (polvere cementizia) B (resina elasticizzante), specifico per la posa a pavimento e a parete di piastrelle ceramiche (gres porcellanato, cotto, klinker, ecc.), materiale lapideo e mosaici, non assorbenti, di grande formato. Resistenza all'umidità: ottima. Resistenza ai solventi e acidi: ottima. Per uso professionale.		Two-pack cement-based adhesive — A (cement powder) B (elasticizing resin) — specifically formulated for laying of large, non-absorbent ceramic (porcelain stoneware, terracotta, klinker, etc.), stone and mosaic wall and floor tiles. Moisture resistance: excellent. Resistance to solvents and acids: excellent For professional use.		Adhesivo cementoso bicomponente A (polvo de cemento) B (resina elástica), específico para la colocación en suelos y paredes de baldosas cerámicas (gres porcelánico, barro cocido, klinker, etc.), material lapídeo y mosaicos, no absorbentes, de gran formato. Resistencia a la humedad: excelente. Resistencia a los disolventes y ácidos: excelente. Para uso profesional.	
<b>Granulometria:</b> max 0,5 mm <b>Attrezzatura:</b> spatola dentata, cazzuola, impastatrice a basso numero di giri <b>Rapporto di miscelazione:</b> 30% con componente B - 7,6 kg per confezione da 25 Kg <b>Consumo:</b> Mosaici Piccoli formati 2 kg/m <sup>2</sup> - standard 2,5-3,5 2 kg/m <sup>2</sup> - Grandi 5,5-6,5 2 kg/m <sup>2</sup> <b>Per sistema:</b> Termok8 Modular Big		<b>Particle Size:</b> max 0.5 mm <b>Equipment:</b> serrated spatula, mason's trowel, low speed mixer. <b>Mixing ratio:</b> 30% with component B - 7.6 kg for 25 kg package <b>Recommended use:</b> Small mosaic tiles 2 kg/m <sup>2</sup> - standard 2.5-3.5 2 kg/m <sup>2</sup> - Large 5.5-6.5 2 kg/m <sup>2</sup> <b>For:</b> Termok8 Modular Big system		<b>Granulometría:</b> máx. 0,5 mm <b>Herramientas:</b> espátula dentada, paleta, amasadora de bajo número de revoluciones <b>Relación de mezcla:</b> 30 % con componente B - 7,6 kg por envase de 25 Kg <b>Consumo:</b> Mosaicos de pequeño formato 2 kg/m <sup>2</sup> - estándar 2,5-3,5 2 kg/m <sup>2</sup> - Grandes 5,5-6,5 2 kg/m <sup>2</sup> <b>Para sistema:</b> Termok8 Modular Big	

tecniche	certificazioni	proprietà	tecnologie

## glueflex modular big bianco

 scheda  
tecnica

 data  
sheet

 ficha  
técnica

adesivo cementizio bicomponente bianco	interno esterno	two-pack cement-based adhesive - white	indoor outdoor	adhesivo cementoso bicomponente blanco	interior exterior
Adesivo cementizio bicomponente A (polvere cementizia) B (resina elasticizzante), specifico per la posa a pavimento e a parete di piastrelle ceramiche (gres porcellanato, cotto, klinker, ecc.), materiale lapideo e mosaici, non assorbenti, di grande formato. Resistenza all'umidità: ottima. Resistenza ai solventi e acidi: ottima. Per uso professionale.		Two-pack cement-based adhesive — A (cement powder) B (elasticizing resin) — specifically formulated for laying of large, non-absorbent ceramic (porcelain stoneware, terracotta, klinker, etc.), stone and mosaic wall and floor tiles. Moisture resistance: excellent. Resistance to solvents and acids: excellent For professional use.		Adhesivo cementoso bicomponente A (polvo de cemento) B (resina elástica), específico para la colocación en suelos y paredes de baldosas cerámicas (gres porcelánico, barro cocido, klinker, etc.), material lapídeo y mosaicos, no absorbentes, de gran formato. Resistencia a la humedad: excelente. Resistencia a los disolventes y ácidos: excelente. Para uso profesional.	
<b>Granulometria:</b> max 0,5 mm <b>Attrezzatura:</b> spatola dentata, cazzuola, impastatrice a basso numero di giri <b>Rapporto di miscelazione:</b> 30% con componente B - 7,6 kg per confezione da 25 Kg <b>Consumo:</b> Mosaici Piccoli formati 2 kg/m <sup>2</sup> - standard 2,5-3,5 2 kg/m <sup>2</sup> - Grandi 5,5-6,5 2 kg/m <sup>2</sup> <b>Per sistema:</b> Termok8 Modular Big		<b>Particle Size:</b> max 0.5 mm <b>Equipment:</b> serrated spatula, mason's trowel, low speed mixer. <b>Mixing ratio:</b> 30% with component B - 7.6 kg for 25 kg package <b>Recommended use:</b> Small mosaic tiles 2 kg/m <sup>2</sup> - standard 2.5-3.5 2 kg/m <sup>2</sup> - Large 5.5-6.5 2 kg/m <sup>2</sup> <b>For:</b> Termok8 Modular Big system		<b>Granulometría:</b> máx. 0,5 mm <b>Herramientas:</b> espátula dentada, paleta, amasadora de bajo número de revoluciones <b>Relación de mezcla:</b> 30 % con componente B - 7,6 kg por envase de 25 Kg <b>Consumo:</b> Mosaicos de pequeño formato 2 kg/m <sup>2</sup> - estándar 2,5-3,5 2 kg/m <sup>2</sup> - Grandes 5,5-6,5 2 kg/m <sup>2</sup> <b>Para sistema:</b> Termok8 Modular Big	

tecniche	certificazioni	proprietà	tecnologie



## glueflex p

scheda  
tecnicadata  
sheetficha  
técnica

adesivo in pasta pronto uso	interno esterno	ready-to-use adhesive in paste form	indoor outdoor	adhesivo en pasta listo para usar	interior exterior
Adesivo in pasta specifico per l'incollaggio e la stuccatura di fughe fra rivestimenti modulari tipo Listello Flex. Ottima lavorabilità, sovraverniciabile, permeabile al vapore acqueo, colorazioni stabili, idoneo solo per lavorazioni a strato sottile. Per uso professionale		Adhesive in paste form specific for gluing and filling joints between modular cladding, such as Flex slips. Very good workability, water vapour permeability, stable colours. Can be overpainted. Suitable only for working in thin-layers. For professional use		Adhesivo en pasta específico para el encolado y emplaste de juntas entre revestimientos modulares tipo Listel Flex. Se trabaja con facilidad, admite recubrimiento de pintura, permeable al vapor de agua, coloraciones estables, idóneo solo para aplicaciones en capa fina. Para uso profesional.	
<b>Attrezzatura:</b> Spatola dentata con dentatura 4x4mm, 4x6mm o 5x5mm, pennello da 10mm <b>Rapporto di miscelazione:</b> pronto uso <b>Consumo:</b> 2.5-3.4 kg/m <sup>2</sup>		<b>Equipment:</b> Serrated spatula with 4x4mm, 4x6mm or 5x5mm serration, 10mm brush <b>Mixing ratio:</b> ready to use <b>Recommended use:</b> 2.5-3.4 kg/m <sup>2</sup>		<b>Herramientas:</b> Espátula dentada con dientes de 4x4 mm, 4x6 mm o 5x5 mm, brocha de 10 mm <b>Relación de mezcla:</b> listo para usar <b>Consumo:</b> 2,5-3,4 kg/m <sup>2</sup>	

tecniche	certificazioni	proprietà	tecnologie
 WATER BASED  BRUSH  TROWEL  READY TO USE			

## parastuck mf

scheda  
tecnicadata  
sheetficha  
técnica

sigillante per fughe grigio	interno esterno	joint sealant - grey	indoor outdoor	sellador para juntas gris	interior exterior
Malta cementizia, idrofugata nella massa per la stuccatura di fughe fra i listelli tipo facciavista fatti a mano in pasta "molla" su pannelli isolanti. Prodotto monocomponente, costituito da una miscela in polvere di cemento, inerti calcarei e silicei selezionati e in granulometria calibrata. Possiede ottime caratteristiche di adesione e resistenza ai cicli di gelo e disgelo. Per uso professionale.		Cement-based mortar, waterproofed in the mass, for filling the joints of hand-made fair-faced brick slips on insulating panels. One-pack product, consisting of a powdered mixture of cement, selected calcareous and silica inert materials of calibrated particle size. They offer superb adhesion properties and resistance to freeze-thaw cycles. For professional use.		Mortero de cemento, hidrófugo de masa para emplastar las juntas de listeles tipo facciavista hechos a mano en pasta "blanda" sobre paneles aislantes. Producto monocomponente, constituido por una mezcla en polvo de cemento, áridos silíceos y calcáreos seleccionados y en granulometría calibrada. Poseen excelentes características de adhesión y resistencia a los ciclos de hielo y deshielo. Para uso profesional.	
<b>Granulometria:</b> max 1,2 mm <b>Attrezzatura:</b> betoniera, spatola, impastatrice a basso numero di giri, cazzuola, ferro da giunti <b>Rapporto di miscelazione:</b> acqua - 17-19% <b>Consumo:</b> non stimabile, dipende dal listello e dalla fuga		<b>Particle Size:</b> max 1.2 mm <b>Equipment:</b> cement mixer, spatula, low speed mixer, mason's trowel, brick jointer <b>Mixing ratio:</b> water - 17-19%. <b>Recommended use:</b> cannot be estimated, depends on the slip and joint		<b>Granulometría:</b> máx. 1,2 mm <b>Herramientas:</b> hormigonera, espátula, amasadora de bajo número de revoluciones, paleta, hierro para juntas <b>Relación de mezcla:</b> agua - 17-19% <b>Consumo:</b> no admite estimaciones, depende del listel y de la junta	

tecniche	certificazioni	proprietà	tecnologie
 WATER BASED  TROWEL			









## converto 30-G

 scheda  
tecnica

 data  
sheet

 ficha  
técnica

### pannello in EPS additivato di grafite detensionato

Pannello isolante detensionato idoneo per l'applicazione a cappotto ETICS, realizzato in polistirene espanso sinterizzato di colore grigio. Realizzato con un contenuto di riciclato  $\geq 10\%$ . Omologato secondo EAD 040083-00-0404 già ETAG 004. Disponibile anche in versione fugato sagomato (fughe decorative).

**Per sistema:** Termok8 Grafite Plus Converto  
**Formato:** 100 x 50 cm  
**Spessore:** da 2 a 20 cm  
**Resistenza a trazione:** TR  $\geq 100$  kPa  
**Classe reazione fuoco del sistema Termok8:** B-s1,d0

### unstressed EPS panel with the addition of graphite

Unstressed insulation panel suitable for ETICS external thermal insulation systems, made of grey sintered expanded polystyrene. Made with  $\geq 10\%$  recycled content. Approved according to EAD 040083-00-0404 (formerly ETAG 004). Also available in grooved versions (decorative groovings).

**For the system:** Termok8 Grafite Plus Converto  
**Size:** 100 x 50 cm  
**Thickness:** from 2 to 20 cm  
**Tensile strength:** TR  $\geq 100$  kPa  
**Termok8 system fire reaction class:** B-s1,d0

### panel en EPS destensado con aditivo de grafito

Panel aislante destensado idóneo para la aplicación por capas SATE, realizado en poliestireno expandido sinterizado de color gris. Realizado con un contenido de reciclado  $\geq 10\%$ . Homologado según EAD 040083-00-0404, antes ETAG 004. Disponible también en versión perfilada (con ranuras decorativas).

**Para sistema:** Termok8 Grafite Plus Converto  
**Medidas:** 100 x 50 cm  
**Espesor:** de 2 a 20 cm  
**Resistencia a la tracción:** TR  $\geq 100$  kPa  
**Clase de reacción al fuego del sistema Termok8:** B-s1,d0

#### tecniche



#### certificazioni



## converto 31-G plus

 scheda  
tecnica

 data  
sheet

 ficha  
técnica

### pannello in EPS additivato di grafite detensionato

Pannello isolante detensionato idoneo per l'applicazione a cappotto ETICS, realizzato in polistirene espanso sinterizzato di colore grigio. Omologato secondo EAD 040083-00-0404 già ETAG 004. Realizzato con un contenuto di riciclato  $\geq 10\%$ . Disponibile anche in versione fugato sagomato (fughe decorative).

**Per sistema:** Termok8 Grafite Plus Converto  
**Formato:** 100 x 50 cm  
**Spessore:** da 2 a 20 cm  
**Resistenza a trazione:** TR  $\geq 100$  kPa  
**Classe reazione fuoco del sistema Termok8:** B-s1,d0

### unstressed EPS panel with the addition of graphite

Unstressed insulation panel suitable for ETICS external thermal insulation systems, made of grey sintered expanded polystyrene. Approved according to EAD 040083-00-0404 (formerly ETAG 004). Made with  $\geq 10\%$  recycled content. Also available in grooved versions (decorative groovings).

**For the system:** Termok8 Grafite Plus Converto  
**Size:** 100 x 50 cm  
**Thickness:** from 2 to 20 cm  
**Tensile strength:** TR  $\geq 100$  kPa  
**Termok8 system fire reaction class:** B-s1,d0

### panel en EPS con aditivo de grafito destensado

Panel aislante destensado idóneo para la aplicación por capas SATE, realizado en poliestireno expandido sinterizado de color gris. Homologado según EAD 040083-00-0404, antes ETAG 004. Realizado con un contenido de reciclado  $\geq 10\%$ . Disponible también en versión perfilada (con ranuras decorativas).

**Para sistema:** Termok8 Grafite Plus Converto  
**Medidas:** 100 x 50 cm  
**Espesor:** de 2 a 20 cm  
**Resistencia a la tracción:** TR  $\geq 100$  kPa  
**Clase de reacción al fuego del sistema Termok8:** B-s1,d0

#### tecniche



#### certificazioni



## converto fonostop



scheda  
tecnica



data  
sheet



ficha  
técnica



pannello in EPS elasticizzato per un miglior isolamento acustico

Pannello isolante elasticizzato ad elevata rigidità dinamica idoneo per l'applicazione a cappotto ETICS, realizzato in polistirene espanso sinterizzato di colore grigio con zigrinatura esterna profonda 6mm. Omologato secondo EAD 040083-00-0404 già ETAG 004. Realizzato con un contenuto di riciclato  $\geq 10\%$ .

**Per sistema:** TermoK8 Fonostop Converto  
**Formato:** 100 x 50 cm  
**Spessore:** da 8 a 20 cm  
**Resistenza a trazione**  $TR \geq 100$  kPa  
**Classe reazione fuoco del sistema TermoK8:** B-s1,d0

elastic EPS panel for better sound insulation

Elastic insulating panel with high dynamic stiffness, suitable for ETICS external thermal insulation systems, made of grey sintered expanded polystyrene with 6mm-deep external grooved pattern. Approved according to EAD 040083-00-0404 (formerly ETAG 004). Made with  $\geq 10\%$  recycled content.

**For the system:** TermoK8 Fonostop Converto  
**Size:** 100 x 50 cm  
**Thickness:** from 8 to 20 cm  
**Tensile strength:**  $TR \geq 100$  kPa  
**TermoK8 system fire reaction class:** B-s1,d0

panel en EPS elastizado para un mejor aislamiento acústico

Panel aislante elastizado de elevada rigidez dinámica idóneo para la aplicación por capas SATE, realizado en poliestireno expandido sinterizado de color gris con moleteado externo de 6 mm de profundidad. Homologado según EAD 040083-00-0404, antes ETAG 004. Realizado con un contenido de reciclado  $\geq 10\%$ .

**Para sistema:** TermoK8 Fonostop Converto  
**Medidas:** 100 x 50 cm  
**Espesor:** de 8 a 20 cm  
**Resistencia a la tracción:**  $TR \geq 100$  kPa  
**Clase de reacción al fuego del sistema TermoK8:** B-s1,d0

### tecniche



### certificazioni



## converto HP



scheda  
tecnica



data  
sheet



ficha  
técnica

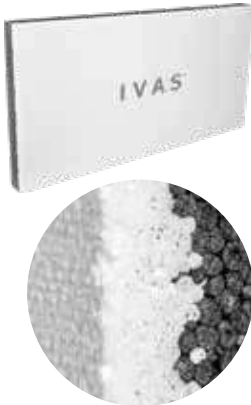

pannello in EPS sintolaminato

Pannello isolante sintolaminato idoneo per l'applicazione a cappotto ETICS, realizzato in polistirene espanso sinterizzato additivato con oltre il 70% di grafite e con strato esterno in EPS bianco per minimizzare gli effetti dell'irraggiamento. Omologato secondo EAD 040083-00-0404 già ETAG 004. Realizzato con un contenuto di riciclato  $\geq 15\%$ .

**Per sistema:** TermoK8 HP Converto  
**Formato:** 120 x 60 cm  
**Spessore:** da 6 a 22 cm  
**Resistenza a trazione**  $TR \geq 150$  kPa  
**Classe reazione fuoco del sistema TermoK8:** B-s1,d0

EPS panel produced by lamination synthesis

Insulating panel produced by lamination synthesis, suitable for ETICS external thermal insulation systems, made of sintered expanded polystyrene with the addition of over 70% graphite and with white EPS outer layer to minimise the effects of radiation. Approved according to EAD 040083-00-0404 (formerly ETAG 004). Made with  $\geq 15\%$  recycled content.

**For the system:** TermoK8 HP Converto  
**Size:** 120 x 60 cm  
**Thickness:** from 6 to 22 cm  
**Tensile strength:**  $TR \geq 150$  kPa  
**TermoK8 system fire reaction class:** B-s1,d0

panel en EPS sintolaminado

Panel aislante sintolaminado idóneo para la aplicación por capas SATE, realizado en poliestireno expandido sinterizado aditivado con más del 70 % de grafito y con capa externa de EPS blanco para reducir al mínimo los efectos de la radiación solar. Homologado según EAD 040083-00-0404, antes ETAG 004. Realizado con un contenido de reciclado  $\geq 15\%$ .

**Para sistema:** TermoK8 HP Converto  
**Medidas:** 120 x 60 cm  
**Espesor:** de 6 a 22 cm  
**Resistencia a la tracción:**  $TR \geq 150$  kPa  
**Clase de reacción al fuego del sistema TermoK8:** B-s1,d0

### tecniche



### certificazioni





## converto 35-100

 scheda  
tecnica

 data  
sheet

 ficha  
técnica

pannello in EPS bianco	EPS panel - white	panel en EPS blanco
<p>Pannello isolante idoneo per l'applicazione a cappotto ETICS, realizzato in polistireno espanso sinterizzato di colore bianco. Omologato secondo EAD 040083-00-0404 già ETAG 004. Realizzato con un contenuto di riciclato <math>\geq 10\%</math>. Disponibile anche in versione fugato sagomato (fughe decorative).</p>	<p>Insulation panel suitable for ETICS external thermal insulation systems, made of white sintered expanded polystyrene. Approved according to EAD 040083-00-0404 (formerly ETAG 004). Made with <math>\geq 10\%</math> recycled content. Also available in grooved versions (decorative groovings).</p>	<p>Panel aislante idóneo para la aplicación por capas SATE, realizado en poliestireno expandido sinterizado de color blanco. Homologado según EAD 040083-00-0404, antes ETAG 004. Realizado con un contenido de reciclado <math>\geq 10\%</math>. Disponible también en versión perfilada (con ranuras decorativas).</p>
<p><b>Per sistema:</b> Termok8 Classico Converto <b>Formato:</b> 100 x 50 cm <b>Spessore:</b> da 2 a 20 cm <b>Resistenza a trazione:</b> TR <math>\geq 150</math> kPa <b>Resistenza a compressione</b> CS(10) <math>\geq 100</math> kPa <b>Classe reazione fuoco del sistema</b> <b>Termok8:</b> B-s1,d0</p>	<p><b>For the system:</b> Termok8 Classico Converto <b>Size:</b> 100 x 50 cm <b>Thickness:</b> from 2 to 20 cm <b>Tensile strength:</b> TR <math>\geq 150</math> kPa <b>Compressive strength:</b> CS(10) <math>\geq 100</math> kPa <b>Termok8 system fire reaction class:</b> B-s1,d0</p>	<p><b>Para sistema:</b> Termok8 Classico Converto <b>Medidas:</b> 100 x 50 cm <b>Espesor:</b> de 2 a 20 cm <b>Resistencia a la tracción:</b> TR <math>\geq 150</math> kPa <b>Resistencia a la compresión</b> CS(10) <math>\geq 100</math> kPa <b>Clase de reacción al fuego del sistema</b> <b>Termok8:</b> B-s1,d0</p>

### tecniche



### certificazioni



## converto P 200

 scheda  
tecnica

 data  
sheet

 ficha  
técnica

pannello in EPS a basso assorbimento d'acqua	EPS panel with low water absorption	panel en EPS de baja absorción de agua
<p>Pannello isolante idoneo per l'applicazione a cappotto ETICS, realizzato in polistireno espanso sinterizzato di colore azzurro a basso assorbimento capillare d'acqua, per le zone perimetrali di zoccolatura. Omologato secondo EAD 040083-00-0404 già ETAG 004. Realizzato con un contenuto di riciclato <math>\geq 10\%</math>.</p>	<p>Insulation panel suitable for ETICS external thermal insulation systems, made of light blue sintered expanded polystyrene with low capillary water absorption, designed for building plinth areas. Approved according to EAD 040083-00-0404 (formerly ETAG 004). Made with <math>\geq 10\%</math> recycled content.</p>	<p>Panel aislante idóneo para la aplicación por capas ETICS, realizado en poliestireno expandido sinterizado de color celeste con baja absorción capilar de agua, para las zonas perimetrales de rodapié. Homologado según EAD 040083-00-0404, antes ETAG 004. Realizado con un contenido de reciclado <math>\geq 10\%</math>.</p>
<p><b>Per sistema:</b> per le fasce di zoccolatura di tutti i sistemi Termok8 <b>Formato:</b> 100 x 50 cm <b>Spessore:</b> da 4 a 20 cm <b>Resistenza a trazione:</b> TR <math>\geq 150</math> kPa <b>Resistenza a compressione</b> CS(10) <math>\geq 150</math> kPa <b>Classe reazione fuoco del sistema</b> <b>Termok8:</b> B-s1,d0</p>	<p><b>For the system:</b> for the plinth areas of all Termok8 systems <b>Size:</b> 100 x 50 cm <b>Thickness:</b> from 4 to 20 cm <b>Tensile strength:</b> TR <math>\geq 150</math> kPa <b>Compressive strength:</b> CS(10) <math>\geq 150</math> kPa <b>Termok8 system fire reaction class:</b> B-s1,d0</p>	<p><b>Para sistema:</b> para las franjas de rodapié de todos los sistemas Termok8 <b>Medidas:</b> 100 x 50 cm <b>Espesor:</b> de 4 a 20 cm <b>Resistencia a la tracción:</b> TR <math>\geq 150</math> kPa <b>Resistencia a la compresión</b> CS(10) <math>\geq 150</math> kPa <b>Clase de reacción al fuego del sistema</b> <b>Termok8:</b> B-s1,d0</p>

### tecniche



### certificazioni





## converto 30 BW

 scheda  
tecnica

 data  
sheet

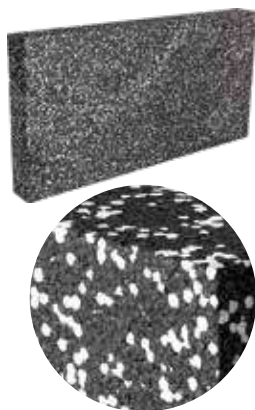
 ficha  
técnica

pannello in EPS additivato di grafite al 70% detensionato

Pannello isolante detensionato idoneo per l'applicazione a cappotto ETICS, realizzato in polistirene espanso sinterizzato di colore grigio/bianco. Omologato secondo EAD 040083-00-0404 già ETAG 004. Realizzato con un contenuto di riciclato  $\geq 10\%$ . Disponibile anche in versione fugato sagomato (fughe decorative).

**Per sistema:** Termok8 BW Converto  
**Formato:** 100 x 50 cm  
**Spessore:** da 2 a 20 cm  
**Resistenza a trazione:** TR  $\geq 140$  kPa  
**Classe reazione fuoco del sistema Termok8:** B-s1,d0

unstressed EPS panel with the addition of 70% graphite

Unstressed insulation panel suitable for ETICS external thermal insulation systems, made of grey/white sintered expanded polystyrene. Approved according to EAD 040083-00-0404 (formerly ETAG 004). Made with  $\geq 10\%$  recycled content. Also available in grooved versions (decorative groovings).

**For the system:** Termok8 BW Converto  
**Size:** 100 x 50 cm  
**Thickness:** from 2 to 20 cm  
**Tensile strength:** TR  $\geq 140$  kPa  
**Termok8 system fire reaction class:** B-s1,d0

panel en EPS aditivado con grafito al 70 % destensado

Panel aislante destensado idóneo para la aplicación por capas SATE, realizado en poliestireno expandido sinterizado de color gris/blanco, homologado según EAD 040083-00-0404, antes ETAG 004. Realizado con un contenido de reciclado  $\geq 10\%$ . Disponible también en versión perfilada (con ranuras decorativas).

**Para sistema:** Termok8 BW Converto  
**Medidas:** 100 x 50 cm  
**Espesor:** de 2 a 20 cm  
**Resistencia a la tracción:** TR  $\geq 140$  kPa  
**Clase de reacción al fuego del sistema Termok8:** B-s1,d0

### tecniche



### certificazioni



## converto 31 BW

 scheda  
tecnica

 data  
sheet

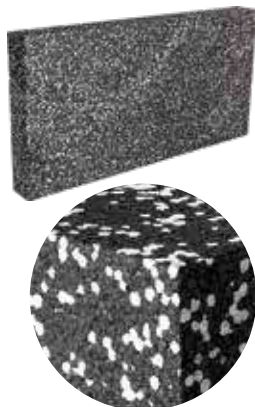
 ficha  
técnica

pannello in EPS additivato di grafite detensionato

Pannello isolante detensionato idoneo per l'applicazione a cappotto ETICS, realizzato in polistirene espanso sinterizzato di colore grigio/bianco. Omologato secondo EAD 040083-00-0404 già ETAG 004. Realizzato con un contenuto di riciclato  $\geq 15\%$ . Disponibile anche in versione fugato sagomato (fughe decorative).

**Per sistema:** Termok8 BW Converto  
**Formato:** 100 x 50 cm  
**Spessore:** da 2 a 20 cm  
**Resistenza a trazione:** TR  $\geq 150$  kPa  
**Classe reazione fuoco del sistema Termok8:** B-s1,d0

unstressed EPS panel with the addition of graphite

Unstressed insulation panel suitable for ETICS external thermal insulation systems, made of grey/white sintered expanded polystyrene. Approved according to EAD 040083-00-0404 (formerly ETAG 004). Made with  $\geq 15\%$  recycled content. Also available in grooved versions (decorative groovings).

**For the system:** Termok8 BW Converto  
**Size:** 100 x 50 cm  
**Thickness:** from 2 to 20 cm  
**Tensile strength:** TR  $\geq 150$  kPa  
**Termok8 system fire reaction class:** B-s1,d0

panel en EPS con aditivo de grafito destensado

Panel aislante destensado idóneo para la aplicación por capas SATE, realizado en poliestireno expandido sinterizado de color gris/blanco. Homologado según EAD 040083-00-0404, antes ETAG 004. Realizado con un contenido de reciclado  $\geq 15\%$ . Disponible también en versión perfilada (con ranuras decorativas).

**Para sistema:** Termok8 BW Converto  
**Medidas:** 100 x 50 cm  
**Espesor:** de 2 a 20 cm  
**Resistencia a la tracción:** TR  $\geq 150$  kPa  
**Clase de reacción al fuego del sistema Termok8:** B-s1,d0

### tecniche



### certificazioni



# converto 34 BW



scheda  
tecnica



data  
sheet



ficha  
técnica

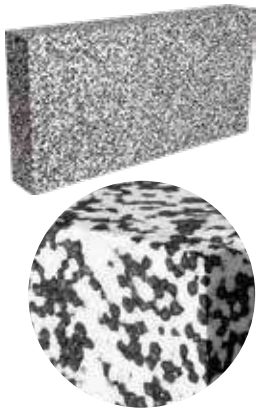

<p><b>pannello in EPS additivato di grafite</b></p> <p>Pannello isolante detensionato idoneo per l'applicazione a cappotto ETICS, realizzato in polistirene espanso sinterizzato di colore bianco/grigio. Omologato secondo EAD 040083-00-0404 già ETAG 004. Realizzato con un contenuto di riciclato <math>\geq 10\%</math>. Disponibile anche in versione fugato sagomato (fughe decorative).</p> <p><b>Per sistema:</b> Termok8 BW Converto  <b>Formato:</b> 100 x 50 cm  <b>Spessore:</b> da 2 a 20 cm  <b>Resistenza a trazione</b> TR <math>\geq 100</math> kPa  <b>Classe reazione fuoco del sistema</b> Termok8: B-s1,d0</p>	<p><b>EPS panel with the addition of graphite</b></p> <p>Unstressed insulation panel suitable for ETICS external thermal insulation systems, made of white/grey sintered expanded polystyrene. Approved according to EAD 040083-00-0404 (formerly ETAG 004). Made with <math>\geq 10\%</math> recycled content. Also available in grooved versions (decorative groovings).</p> <p><b>For the system:</b> Termok8 BW Converto  <b>Size:</b> 100 x 50 cm  <b>Thickness:</b> from 2 to 20 cm  <b>Tensile strength:</b> TR <math>\geq 100</math> kPa  <b>Termok8 system fire reaction class:</b> B-s1,d0</p>	<p><b>panel en EPS con aditivo de grafito</b></p> <p>Panel aislante destensado idóneo para la aplicación por capas SATE, realizado en poliestireno expandido sinterizado de color blanco/gris. Homologado según EAD 040083-00-0404, antes ETAG 004. Realizado con un contenido de reciclado <math>\geq 10\%</math>. Disponible también en versión perfilada (con ranuras decorativas).</p> <p><b>Para sistema:</b> Termok8 BW Converto  <b>Medidas:</b> 100 x 50 cm  <b>Espesor:</b> de 2 a 20 cm  <b>Resistencia a la tracción:</b> TR <math>\geq 100</math> kPa  <b>Clase de reacción al fuego del sistema</b> Termok8: B-s1,d0</p>
--	--	---

**tecniche**



**certificazioni**



## eps 35 max R

 scheda  
tecnica

 data  
sheet

 ficha  
técnica

pannello in EPS per una maggiore resistenza agli urti

Pannello isolante detensionato idoneo per l'applicazione a cappotto ETICS, realizzato in polistirene espanso sinterizzato con zigrinatura esterna per migliorare la resistenza agli urti del sistema  $\geq 20$  J e 60 J. Omologato secondo EAD 040083-00-0404 già ETAG 004. Realizzato con un contenuto di riciclato  $\geq 15\%$ .

**Per sistemi:** Termok8 A.R. Max 20 J e Termok8 A.R. Max 60 J  
**Formato:** 100 x 50 cm  
**Spessore:** da 4 a 20 cm  
**Resistenza a trazione** TR  $\geq 150$  kPa  
**Classe reazione fuoco del sistema**  
**Termok8:** B-s1,d0

EPS panel for increased impact resistance

Unstressed insulation panel suitable for ETICS external thermal insulation systems, made of sintered expanded polystyrene with external grooved pattern to improve system impact resistance  $\geq 20$  J and 60 J. Approved according to EAD 040083-00-0404 (formerly ETAG 004). Made with  $\geq 15\%$  recycled content.

**For the systems:** Termok8 A.R. Max 20 J and Termok8 A.R. Max 60 J  
**Size:** 100 x 50 cm  
**Thickness:** from 4 to 20 cm  
**Tensile strength:** TR  $\geq 150$  kPa  
**Termok8 system fire reaction class:**  
**B-s1,d0**

panel en EPS para una mayor resistencia a los golpes

Panel aislante destensado idóneo para la aplicación por capas SATE, realizado en poliestireno expandido sinterizado, con moleteado externo para mejorar la resistencia a los golpes del sistema  $\geq 20$  J y 60 J. Homologado según EAD 040083-00-0404, antes ETAG 004. Realizado con un contenido de reciclado  $\geq 15\%$ .

**Para sistemas:** Termok8 A.R. Máx 20 J y Termok8 A.R. Máx 60 J  
**Medidas:** 100 x 50 cm  
**Espesor:** de 4 a 20 cm  
**Resistencia a la tracción:** TR  $\geq 150$  kPa  
**Clase de reacción al fuego del sistema**  
**Termok8:** B-s1,d0

### tecniche



### certificazioni



## eps 35-100 fix R

 scheda  
tecnica

 data  
sheet

 ficha  
técnica

pannello in EPS per sistemi modulari

Pannello isolante idoneo per l'applicazione a cappotto ETICS, realizzato in polistirene espanso sinterizzato di colore bianco con zigrinatura su entrambi i lati e, sulla superficie esterna, quattro scassi trasversali ribassati. Realizzato con un contenuto di riciclato  $\geq 10\%$ .

**Per sistemi:** Termok8 Modular Design  
**Formato:** 100 x 50 cm  
**Spessore:** da 4 a 20 cm  
**Resistenza a trazione** TR  $\geq 150$  kPa  
**Resistenza a compressione** CS(10)  $\geq 100$  kPa  
**Classe reazione fuoco del sistema**  
**Termok8:** B-s1,d0

EPS panel for modular systems

Insulation panel suitable for ETICS external thermal insulation systems, made of white sintered expanded polystyrene with grooved pattern on both sides and four deep transversal grooves on the external surface. Made with  $\geq 10\%$  recycled content.

**For the systems:** Termok8 Modular Design  
**Size:** 100 x 50 cm  
**Thickness:** from 4 to 20 cm  
**Tensile strength:** TR  $\geq 150$  kPa  
**Compressive strength:** CS(10)  $\geq 100$  kPa  
**Termok8 system fire reaction class:**  
**B-s1,d0**

panel en EPS para sistemas modulares

Panel aislante idóneo para la aplicación por capas SATE, realizado en poliestireno expandido sinterizado de color blanco con moleteado en los dos lados y cuatro cavidades transversales rebajadas en la superficie externa. Realizado con un contenido de reciclado  $\geq 10\%$ .

**Para sistemas:** Termok8 Modular Design  
**Medidas:** 100 x 50 cm  
**Espesor:** de 4 a 20 cm  
**Resistencia a la tracción:** TR  $\geq 150$  kPa  
**Resistencia a la compresión** CS(10)  $\geq 100$  kPa  
**Clase de reacción al fuego del sistema**  
**Termok8:** B-s1,d0

### tecniche



### certificazioni



## eps meccanico R

 scheda  
tecnica

 data  
sheet

 ficha  
técnica

pannello in EPS per supporti difficili

Pannello isolante idoneo per l'applicazione a cappotto ETICS, realizzato in polistirene espanso sinterizzato di colore bianco, fresato lungo i quattro lati con un'opportuna scanalatura per il fissaggio dei profili del sistema meccanico. Realizzato con un contenuto di riciclato  $\geq 15\%$ .

**Per sistema:** Termok8 Meccanico  
**Formato:** 60 x 60 cm  
**Spessore:** da 5 a 20 cm  
**Resistenza a trazione** TR  $\geq 200$  kPa  
**Classe reazione fuoco del sistema**  
**Termok8:** B-s2,d0

EPS panel for difficult substrates

Insulation panel suitable for ETICS external thermal insulation systems, made of white sintered expanded polystyrene with grooves cut into all four sides to fasten the mechanical system profiles. Made with  $\geq 15\%$  recycled content.

**For the system:** Termok8 Meccanico  
**Size:** 60 x 60 cm  
**Thickness:** from 5 to 20 cm  
**Tensile strength:** TR  $\geq 200$  kPa  
**Termok8 system fire reaction class:**  
**B-s2,d0**

panel en EPS para soportes difíciles

Panel aislante idóneo para la aplicación por capas SATE, realizado en poliestireno expandido sinterizado de color blanco, frendimentado a lo largo de los cuatro lados con una ranura para la fijación de los perfiles del sistema mecánico. Realizado con un contenido de reciclado  $\geq 15\%$ .

**Para sistema:** Termok8 Meccanico  
**Medidas:** 60 x 60 cm  
**Espesor:** de 5 a 20 cm  
**Resistencia a la tracción:** TR  $\geq 200$  kPa  
**Clase de reacción al fuego del sistema**  
**Termok8:** B-s2,d0

### tecniche



### certificazioni





## eps 31-G max R



scheda  
tecnica



data  
sheet



ficha  
técnica

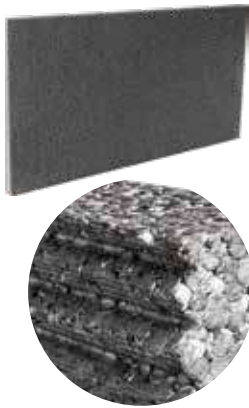

pannello in EPS additivato di grafite	EPS panel with the addition of graphite	panel en EPS con aditivo de grafito
Pannello isolante detensionato idoneo per l'applicazione a cappotto ETICS, realizzato in polistirene espanso sinterizzato di colore grigio con zigrinatura esterna per migliorare la resistenza agli urti del sistema $\geq 20$ J e 60 J. Omologato secondo EAD 040083-00-0404 già ETAG 004. Realizzato con un contenuto di riciclato $\geq 15\%$ .	Unstressed insulation panel suitable for ETICS external thermal insulation systems, made of grey sintered expanded polystyrene with external grooved pattern to improve system impact resistance $\geq 20$ J and 60 J. Approved according to EAD 040083-00-0404 (formerly ETAG 004). Made with $\geq 15\%$ recycled content.	Panel aislante destensado idóneo para la aplicación por capas SATE, realizado en poliestireno expandido sinterizado de color gris con moleteado externo para mejorar la resistencia a los golpes del sistema $\geq 20$ J y 60 J. Homologado según EAD 040083-00-0404 antes ETAG 004. Realizado con un contenido de reciclado $\geq 15\%$ .
<b>Per sistemi:</b> TermoK8 A.R. Max 20 J e TermoK8 A.R. Max 60 J <b>Formato:</b> 100 x 50 cm <b>Spessore:</b> da 4 a 20 cm <b>Resistenza a trazione</b> TR $\geq 120$ kPa <b>Classe reazione fuoco del sistema TermoK8:</b> B-s1,d0	<b>For the systems:</b> TermoK8 A.R. Max 20 J and TermoK8 A.R. Max 60 J <b>Size:</b> 100 x 50 cm <b>Thickness:</b> from 4 to 20 cm <b>Tensile strength:</b> TR $\geq 120$ kPa <b>TermoK8 system fire reaction class:</b> B-s1,d0	<b>Para sistemas:</b> TermoK8 A.R. Máx 20 J y TermoK8 A.R. Max 60 J <b>Medidas:</b> 100 x 50 cm <b>Espesor:</b> de 4 a 20 cm <b>Resistencia a la tracción:</b> TR $\geq 120$ kPa <b>Clase de reacción al fuego del sistema TermoK8:</b> B-s1,d0

### tecniche



### certificazioni



## eps 31-G 100 fix R



scheda  
tecnica



data  
sheet



ficha  
técnica

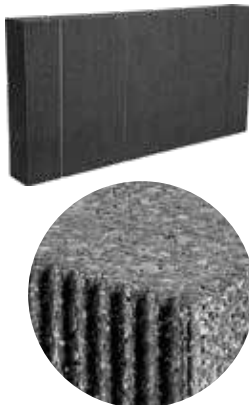

pannello in EPS additivato di grafite per sistemi modulari	unstressed EPS panel with the addition of graphite	panel en EPS con aditivo de grafito destensado
Pannello isolante idoneo per l'applicazione a cappotto ETICS, realizzato in polistirene espanso sinterizzato di colore grigio con zigrinatura su entrambi i lati e, sulla superficie esterna, quattro scassi trasversali ribassati. Realizzato con un contenuto di riciclato $\geq 10\%$ .	Insulation panel suitable for ETICS external thermal insulation systems, made of grey sintered expanded polystyrene with grooved pattern on both sides and four deep transversal grooves on the external surface. Made with $\geq 10\%$ recycled content.	Panel aislante idóneo para la aplicación por capas SATE, realizado en poliestireno expandido sinterizado de color gris con moleteado en los dos lados y cuatro cavidades transversales rebajadas en la superficie externa. Con contenido de reciclado $\geq 10\%$ .
<b>Per sistemi:</b> TermoK8 Modular Design <b>Formato:</b> 100 x 50 cm <b>Spessore:</b> da 4 a 20 cm <b>Resistenza a trazione</b> TR $\geq 150$ kPa <b>Resistenza a compressione</b> CS(10) $\geq 100$ kPa <b>Classe reazione fuoco del sistema TermoK8:</b> B-s1,d0	<b>For the systems:</b> TermoK8 Modular Design <b>Size:</b> 100 x 50 cm <b>Thickness:</b> from 4 to 20 cm <b>Tensile strength:</b> TR $\geq 150$ kPa <b>Compressive strength:</b> CS(10) $\geq 100$ kPa <b>TermoK8 system fire reaction class:</b> B-s1,d0	<b>Para sistemas:</b> TermoK8 Modular Design <b>Medidas:</b> 100 x 50 cm <b>Espesor:</b> de 4 a 20 cm <b>Resistencia a la tracción:</b> TR $\geq 150$ kPa <b>Resistencia a la compresión</b> CS(10) $\geq 100$ kPa <b>Clase de reacción al fuego del sistema TermoK8:</b> B-s1,d0

### tecniche



### certificazioni



## eps G meccanico R



scheda  
tecnica



data  
sheet



ficha  
técnica

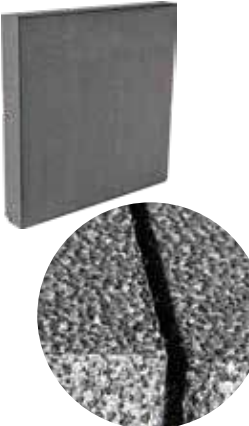

pannello in EPS additivato di grafite per supporti difficili	EPS panel with the addition of graphite for difficult substrates	panel en EPS con aditivo de grafito para soportes difíciles
Pannello isolante idoneo per l'applicazione a cappotto ETICS, realizzato in polistirene espanso sinterizzato di colore grigio, fresato lungo i quattro lati con un'opportuna scanalatura per il fissaggio dei profili del sistema meccanico. Realizzato con un contenuto di riciclato $\geq 15\%$ .	Insulation panel suitable for ETICS external thermal insulation systems, made of grey sintered expanded polystyrene with grooves cut into all four sides to fasten the profiles of the mechanical system. Made with $\geq 15\%$ recycled content.	Panel aislante idóneo para la aplicación por capas SATE, realizado en poliestireno expandido sinterizado de color gris, fRendimiento a lo largo de los cuatro lados con una ranura para la fijación de los perfiles del sistema mecánico. Realizado con un contenido de reciclado $\geq 15\%$ .
<b>Per sistema:</b> TermoK8 Meccanico <b>Formato:</b> 60 x 60 cm <b>Spessore:</b> da 5 a 20 cm <b>Resistenza a trazione</b> TR $\geq 150$ kPa <b>Classe reazione fuoco del sistema TermoK8:</b> B-s2,d0	<b>For the system:</b> TermoK8 Meccanico <b>Size:</b> 60 x 60 cm <b>Thickness:</b> from 5 to 20 cm <b>Tensile strength:</b> TR $\geq 150$ kPa <b>TermoK8 system fire reaction class:</b> B-s2,d0	<b>Para sistema:</b> TermoK8 Meccanico <b>Medidas:</b> 60 x 60 cm <b>Espesor:</b> de 5 a 20 cm <b>Resistencia a la tracción:</b> TR $\geq 150$ kPa <b>Clase de reacción al fuego del sistema TermoK8:</b> B-s2,d0

### tecniche



### certificazioni



## converto P 200 HP



scheda  
tecnica



data  
sheet



ficha  
técnica



pannello in EPS sintolaminato a basso assorbimento d'acqua

Pannello isolante idoneo per l'applicazione a cappotto ETICS, realizzato in polistirene espanso sinterizzato additivato con oltre il 70% di grafite, e con strato esterno in EPS di colore azzurro, a basso assorbimento capillare d'acqua, per le zone perimetrali di zoccolatura. Omologato secondo EAD 040083-00-0404 già ETAG 004. Realizzato con un contenuto di riciclato  $\geq 15\%$ .

Per le fasce di zoccolatura di tutti i sistema Termok8

**Formato:** 120 x 60 cm

**Spessore:** da 6 a 20 cm

**Resistenza a trazione** TR  $\geq 150$  kPa

**Classe reazione fuoco del sistema Termok8:** B-s1,d0

EPS panel produced by lamination synthesis with low water absorption

Insulation panel suitable for ETICS external thermal insulation systems, made of sintered expanded polystyrene with the addition of over 70% graphite and external surface in light blue EPS. Offers low capillary water absorption, designed for building plinth areas. Approved according to EAD 040083-00-0404 (formerly ETAG 004). Made with  $\geq 15\%$  recycled content.

For the plinth areas of all Termok8 systems

**Size:** 120 x 60 cm

**Thickness:** from 6 to 20 cm

**Tensile strength:** TR  $\geq 150$  kPa

**Termok8 system fire reaction class:**

B-s1,d0

panel en EPS sintolaminado de baja absorción de agua

Panel aislante idóneo para la aplicación por capas SATE, realizado en poliestireno expandido sinterizado aditivado con más del 70 % de grafito, y con una capa externa en EPS de color celeste, de baja absorción capilar de agua, para las zonas perimetrales de rodapié. Homologado según EAD 040083-00-0404, antes ETAG 004. Realizado con un contenido de reciclado  $\geq 15\%$ .

Para las franjas de rodapié de todos los sistemas Termok8

**Medidas:** 120 x 60 cm

**Espesor:** de 6 a 20 cm

**Resistencia a la tracción:** TR  $\geq 150$  kPa

**Clase de reacción al fuego del sistema**

**Termok8:** B-s1,d0

### tecniche



### certificazioni



## reverso



scheda  
tecnica



data  
sheet



ficha  
técnica



pannello in EPS sintolaminato 100% riciclato

Pannello isolante idoneo per l'applicazione a cappotto ETICS, realizzato in polistirene espanso sinterizzato additivato con oltre il 70% di grafite e con strato esterno in EPS verde con contenuto di materiale riciclato al 100% derivato da materie prime rinnovabili secondo il metodo Biomass Balance certificato Bureau Veritas al disciplinare tecnico Remade in Italy. Omologato secondo EAD 040083-00-0404 già ETAG 004.

**Per sistema:** Termok8 HP green

**Formato:** 120 x 60 cm

**Spessore:** da 6 a 22 cm

**Resistenza a trazione** TR  $\geq 150$  kPa

**Classe reazione fuoco del sistema**

**Termok8:** B-s1,d0

100% recycled EPS panel produced by lamination synthesis

Insulating panel suitable for ETICS external thermal insulation systems, made of sintered expanded polystyrene with the addition of over 70% graphite and external surface in green EPS with 100% recycled content derived entirely from renewable raw materials according to the Biomass Balance method certified by Bureau Veritas and Remade in Italy technical specifications. Approved according to EAD 040083-00-0404 (formerly ETAG 004).

**For the system:** Termok8 HP green

**Size:** 120 x 60 cm

**Thickness:** from 6 to 22 cm

**Tensile strength:** TR  $\geq 150$  kPa

**Termok8 system fire reaction class:**

B-s1,d0

panel en EPS sintolaminado 100 % reciclado

Panel aislante idóneo para la aplicación por capas SATE, realizado en poliestireno expandido sinterizado aditivado con más del 70 % de grafito y con capa externa de EPS verde con contenido de material reciclado al 100 % derivado de materias primas renovables según el método Biomass Balance certificado Bureau Veritas según el pliego de especificaciones técnicas Remade in Italy. Homologado según EAD 040083-00-0404, antes ETAG 004.

**Para sistema:** Termok8 HP green

**Medidas:** 120 x 60 cm

**Espesor:** de 6 a 22 cm

**Resistencia a la tracción:** TR  $\geq 150$  kPa

**Clase de reacción al fuego del sistema**

**Termok8:** B-s1,d0

### tecniche



### certificazioni







## eps 35 plus

scheda  
tecnicadata  
sheetficha  
técnica

pannello in EPS bianco detensionato	unstressed EPS panel - white	panel en EPS blanco destensado
Pannello isolante detensionato idoneo per l'applicazione a cappotto ETICS, realizzato in polistirene espanso sinterizzato di colore bianco. Omologato secondo EAD 040083-00-0404 già ETAG 004. Disponibile anche in versione fugato sagomato (fughe decorative)	Unstressed insulation panel suitable for ETICS external thermal insulation systems, made of white sintered expanded polystyrene. Approved according to EAD 040083-00-0404 (formerly ETAG 004). Also available in grooved versions (decorative groovings).	Panel aislante destensado idóneo para la aplicación por capas SATE, realizado en poliestireno expandido sinterizado de color blanco. Homologado según EAD 040083-00-0404, antes ETAG 004. Disponible también en versión para juntas perfiladas (juntas decorativas)
<b>Per sistema:</b> Termok8 Classico 35 Plus <b>Formato:</b> 100 x 50 cm <b>Spessore:</b> da 2 a 20 cm <b>Resistenza a trazione</b> TR ≥ 150 kPa <b>Classe reazione fuoco del sistema</b> <b>Termok8:</b> B-s1,d0	<b>For the system:</b> Termok8 Classico 35 Plus <b>Size:</b> 100 x 50 cm <b>Thickness:</b> from 2 to 20 cm <b>Tensile strength:</b> TR ≥ 150 kPa <b>Termok8 system fire reaction class:</b> B-s1,d0	<b>Para sistema:</b> Termok8 Classico 35 Plus <b>Medidas:</b> 100 x 50 cm <b>Espesor:</b> de 2 a 20 cm <b>Resistencia a la tracción:</b> TR ≥ 150 kPa <b>Clase de reacción al fuego del sistema</b> <b>Termok8:</b> B-s1,d0

## tecniche



## certificazioni







## lana di roccia monodensità



scheda  
tecnica



data  
sheet



ficha  
técnica



### pannello in lana di roccia monodensità

Pannello isolante in lana minerale di roccia (MW) idoneo per l'applicazione a cappotto ETICS, biosolubile, incombustibile, con elevate prestazioni di isolamento termico, acustico e con elevata diffusività al vapore. Omologato secondo EAD 040083-00-0404 già ETAG 004. Fornibile su richiesta nella versione con primer ai silicati di calcio su un lato per facilitare la posa della rasatura. Su ordinazione sono disponibili pannelli con  $\lambda = 0,035 \text{ W/m}\cdot\text{K}$  e  $\lambda = 0,036 \text{ W/m}\cdot\text{K}$

**Per i sistemi:** Termok8 Minerale L.R. e Termok8 Modular Flex L.R.  
**Formato:** 100 x 60 cm  
**Spessore:** da 6 a 20 cm  
**Resistenza a trazione**  $TR \geq 7,5 \text{ kPa}$   
**Classe reazione fuoco del sistema**  
**Termok8:** A2-s1,d0

### single-density rock wool panel

Rock mineral wool insulation panel (MW) suitable for ETICS external thermal insulation systems. Biosoluble, non-combustible, provides high thermal and acoustic insulation performance and high vapour diffusivity. Approved according to EAD 040083-00-0404 (formerly ETAG 004). Upon request, can be supplied with calcium silicate primer on one side to facilitate application of the skim coat. Panels with  $\lambda = 0.035 \text{ W/m}\cdot\text{K}$  and  $\lambda = 0.036 \text{ W/m}\cdot\text{K}$  available upon request.

**For the systems:** Termok8 Minerale L.R. and Termok8 Modular Flex L.R.  
**Size:** 100 x 60 cm  
**Thickness:** from 6 to 20 cm  
**Tensile strength:**  $TR \geq 7.5 \text{ kPa}$   
**Termok8 system fire reaction class:** A2-s1,d0

### panel en lana de roca monodensidad

Panel aislante en lana mineral de roca (MW) idóneo para la aplicación por capas SATE, biosoluble, incombustible, con altas prestaciones de aislamiento térmico, acústico y con gran capacidad de difusión del vapor. Homologado según EAD 040083-00-0404, antes ETAG 004. Bajo pedido puede suministrarse en la versión con imprimación de silicatos de calcio por un lado para facilitar la aplicación del enrasado. Bajo pedido hay disponibles paneles con  $\lambda = 0,035 \text{ W/m}\cdot\text{K}$  y  $\lambda = 0,036 \text{ W/m}\cdot\text{K}$

**Para sistemas:** Termok8 Minerale L.R. y Termok8 Modular Flex L.R.  
**Medidas:** 100 x 60 cm  
**Espesor:** de 6 a 20 cm  
**Resistencia a la tracción:**  $TR \geq 7,5 \text{ kPa}$   
**Clase de reacción al fuego del sistema**  
**Termok8:** A2-s1,d0

#### tecniche



#### certificazioni



## lana di roccia doppia densità



scheda  
tecnica



data  
sheet



ficha  
técnica



### pannello in lana di roccia a doppia densità

Pannello isolante in lana minerale di roccia (MW) idoneo per l'applicazione a cappotto ETICS, biosolubile, incombustibile, con elevate prestazioni di isolamento termico, acustico e con elevata diffusività al vapore. Omologato secondo EAD 040083-00-0404 già ETAG 004.

**Per i sistemi:** Termok8 Minerale L.R. e Termok8 Modular Flex L.R.  
**Formato:** 120 x 60 cm  
**Spessore:** da 6 a 20 cm  
**Resistenza a trazione**  $TR \geq 7,5 \text{ kPa}$   
**Classe reazione fuoco del sistema**  
**Termok8:** A2-s1,d0

### double-density rock wool panel

Mineral rock wool insulation panel (MW) suitable for ETICS external thermal insulation systems. Biosoluble, non-combustible, provides high thermal and acoustic insulation performance and high vapour diffusivity. Approved according to EAD 040083-00-0404 (formerly ETAG 004).

**For the systems:** Termok8 Minerale L.R. and Termok8 Modular Flex L.R.  
**Size:** 120 x 60 cm  
**Thickness:** from 6 to 20 cm  
**Tensile strength:**  $TR \geq 7.5 \text{ kPa}$   
**Termok8 system fire reaction class:** A2-s1,d0

### panel en lana de roca de doble densidad

Panel aislante en lana mineral de roca (MW) idóneo para la aplicación por capas SATE, biosoluble, incombustible, con altas prestaciones de aislamiento térmico, acústico y con gran capacidad de difusión del vapor. Homologado según EAD 040083-00-0404, antes ETAG 004.

**Para sistemas:** Termok8 Minerale L.R. y Termok8 Modular Flex L.R.  
**Medidas:** 120 x 60 cm  
**Espesor:** de 6 a 20 cm  
**Resistencia a la tracción:**  $TR \geq 7,5 \text{ kPa}$   
**Clase de reacción al fuego del sistema**  
**Termok8:** A2-s1,d0

#### tecniche



#### certificazioni



## lana di vetro k34



scheda  
tecnica



data  
sheet



ficha  
técnica



pannello in lana di vetro	glass fibre panel	panel en lana de vidrio
<p>Pannello isolante in lana minerale di vetro (MW) idoneo per l'applicazione a cappotto ETICS, biosolubile, incombustibile, con elevate prestazioni di isolamento termico, acustico e con elevata diffusività al vapore. Prodotto in Italia con almeno l'80% di vetro riciclato. Omologato secondo EAD 040083-00-0404 già ETAG 004.</p>	<p>Mineral glass fibre insulation panel (MW) suitable for ETICS external thermal insulation systems. Biosoluble, non-combustible, provides high thermal and acoustic insulation performance and high vapour diffusivity. Made in Italy with at least 80% recycled glass. Approved according to EAD 040083-00-0404 (formerly ETAG 004).</p>	<p>Panel aislante en lana mineral de vidrio (MW) idóneo para la aplicación por capas SATE, biosoluble, incombustible, con altas prestaciones de aislamiento térmico, acústico y con gran capacidad de difusión del vapor. Producido en Italia con un mínimo del 80 % de vidrio reciclado. Homologado según EAD 040083-00-0404, antes ETAG 004.</p>
<p><b>Per sistema:</b> TermoK8 Minerale L.V. <b>Formato:</b> 120 x 60 cm <b>Spessore:</b> da 6 a 20 cm <b>Resistenza a trazione</b> TR ≥ 7,5 kPa <b>Classe reazione fuoco del sistema</b> TermoK8: A2-s1,d0</p>	<p><b>For the system:</b> TermoK8 Minerale L.V. <b>Size:</b> 120 x 60 cm <b>Thickness:</b> from 6 to 20 cm <b>Tensile strength:</b> TR ≥ 7,5 kPa <b>TermoK8 system fire reaction class:</b> A2-s1,d0</p>	<p><b>Para sistema:</b> TermoK8 Minerale L.V. <b>Medidas:</b> 120 x 60 cm <b>Espesor:</b> de 6 a 20 cm <b>Resistencia a la tracción:</b> TR ≥ 7,5 kPa <b>Clase de reacción al fuego del sistema</b> TermoK8: A2-s1,d0</p>

### tecniche



### certificazioni



## multipor



scheda  
tecnica



data  
sheet



ficha  
técnica



pannello minerale	mineral panel	panel mineral
<p>Pannello isolante minerale idoneo per l'applicazione a cappotto ETICS, a base di idrati di silicato di calcio autoclavato, incombustibile e con elevata diffusività al vapore. Dotato di omologazione ETA 05/0093 secondo EAD 040012-00-1201.</p>	<p>Mineral insulation panel suitable for ETICS external thermal insulation systems. Contains autoclaved calcium silicate hydrates, is non-combustible and provides high vapour diffusivity. ETA 05/0093-certified according to EAD 040012-00-1201.</p>	<p>Panel aislante mineral idóneo para la aplicación por capas SATE, a base de hidratos de silicato de calcio autoclavado, incombustible y con gran capacidad de difusión del vapor. Homologado ETA 05/0093 según EAD 040012-00-1201.</p>
<p><b>Per sistema:</b> TermoK8 Minerale Eco <b>Formato:</b> 60 x 39 cm <b>Spessore:</b> da 6 a 14 cm <b>Resistenza a trazione</b> TR ≥ 80 kPa <b>Resistenza a compressione</b> CS(10) ≥ 300 kPa <b>Classe reazione fuoco del pannello:</b> A1</p>	<p><b>For the system:</b> TermoK8 Minerale Eco <b>Size:</b> 60 x 39 cm <b>Thickness:</b> from 6 to 14 cm <b>Tensile strength:</b> TR ≥ 80 kPa <b>Compressive strength:</b> CS(10) ≥ 300 kPa <b>Panel fire reaction class:</b> A1</p>	<p><b>Para sistema:</b> TermoK8 Minerale Eco <b>Medidas:</b> 60 x 39 cm <b>Espesor:</b> de 6 a 14 cm <b>Resistencia a la tracción:</b> TR ≥ 80 kPa <b>Resistencia a la compresión</b> CS(10) ≥ 300 kPa <b>Clase de reacción al fuego del panel:</b> A1</p>

### tecniche



### certificazioni



## stiferite class SK

scheda  
tecnicadata  
sheetficha  
técnicapannello in poliuretano espanso  
rigido

Pannello isolante in schiuma polyiso espansa (PIR), idoneo per l'applicazione a cappotto ETICS, con elevate prestazioni di isolamento termico, rivestito su entrambe le facce con velo vetro saturato. Omologato secondo EAD 040083-00-0404 già ETAG 004.

**Per sistema:** Termok8 Slim  
**Formato:** 120 x 60 cm  
**Spessore:** da 2 a 20 cm  
**Resistenza a trazione** TR ≥ 80 kPa  
**Classe reazione fuoco del sistema**  
**Termok8:** B-s1,d0

## rigid polyurethane foam panel

Polyiso foam insulation panel (PIR), suitable for ETICS external thermal insulation systems, with high thermal insulation performance, coated on both sides with a thin film of saturated glass. Approved according to EAD 040083-00-0404 (formerly ETAG 004).

**For the system:** Termok8 Slim  
**Size:** 120 x 60 cm  
**Thickness:** from 2 to 20 cm  
**Tensile strength:** TR ≥ 80 kPa  
**Termok8 system fire reaction class:**  
B-s1,d0

panel en poliuretano expandido  
rígido

Panel aislante en espuma polyiso (PIR), idóneo para la aplicación por capas SATE, con altas prestaciones de aislamiento térmico, revestido por las dos caras con velo de vidrio saturado. Homologado según EAD 040083-00-0404, antes ETAG 004.

**Para sistema:** Termok8 Slim  
**Medidas:** 120 x 60 cm  
**Espesor:** de 2 a 20 cm  
**Resistencia a la tracción:** TR ≥ 80 kPa  
**Clase de reacción al fuego del sistema**  
**Termok8:** B-s1,d0

## tecniche



## certificazioni



## sughero ambrato

scheda  
tecnicadata  
sheetficha  
técnica

## pannello in sughero ambrato

Pannello per isolamento termo-acustico realizzato in sughero espanso, autocollato, idoneo per l'applicazione a cappotto ETICS, totalmente naturale poiché ottenuto tramite processo termico di tostatura, quindi senza aggiunta di colle o di sostanze chimiche, certificato secondo UNI EN 13170. Certificato per la bioedilizia da Natureplus, ANAB ed ICEA.

**Per sistema:** Termok8 Sughero  
**Formato:** 100 x 50 cm  
**Spessore:** da 3 a 18 cm  
**Densità:** 110 kg/m<sup>3</sup>  
**Resistenza a compressione** CS(10) ≥ 100 kPa

## amber cork panel

Thermal and acoustic insulation panel made of self-adhesive expanded cork, suitable for ETICS external thermal insulation systems. It is totally natural since it is obtained through a thermal toasting process which does not use glues or chemical substances. UNI EN 13170 certified. Certified for green housing by Natureplus, ANAB and ICEA.

**For the system:** Termok8 Sughero  
**Size:** 100 x 50 cm  
**Thickness:** from 3 to 18 cm  
**Density:** 110 kg/m<sup>3</sup>  
**Compressive strength:** CS(10) ≥ 100 kPa

## panel en corcho ámbar

Panel para aislamiento termo-acústico realizado en corcho expandido, autoencolado, idóneo para la aplicación por capas SATE, totalmente natural porque se obtiene mediante proceso térmico de tostado, es decir, sin añadido de colas o de sustancias químicas, certificado según UNI EN 13170. Certificado para eco-arquitectura por Natureplus, ANAB y ICEA.

**Para sistema:** Termok8 Sughero (corcho)  
**Medidas:** 100 x 50 cm  
**Espesor:** de 3 a 18 cm  
**Densidad:** 110 kg/m<sup>3</sup>  
**Resistencia a la compresión** CS(10) ≥ 100 kPa

## tecniche



## certificazioni

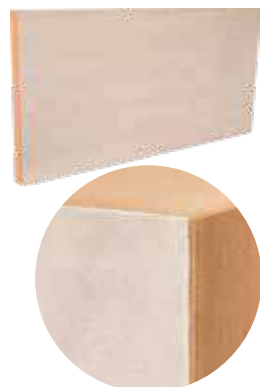

## PH 20

scheda  
tecnicadata  
sheetficha  
técnicapannello in resina fenolica espansa  
rigida

Pannello isolante in schiuma di resina fenolica espansa (PF), idoneo per l'applicazione a cappotto ETICS, con elevate prestazioni di isolamento termico, rivestito su entrambi i lati con velo vetro saturato. Omologato secondo UNI EN 13166.

**Per sistema:** Termok8 Fenolico  
**Formato:** 120 x 60 cm (per lastre da 2 e 3 cm dimensione lastra 120x120 cm)  
**Spessore:** da 2 a 16 cm  
**Resistenza a trazione** TR ≥ 80 kPa  
**Classe reazione fuoco del sistema**  
**Termok8:** B-s1,d0

## rigid phenolic resin foam panel

Phenolic resin foam (PF) insulation panel, suitable for ETICS external thermal insulation systems, with high thermal insulation performance, coated on both sides with a thin film of saturated glass. Approved according to UNI EN 13166.

**For the system:** Termok8 Fenolico  
**Size:** 120 x 60 cm (for 2 and 3 cm slabs measuring 120x120 cm)  
**Thickness:** from 2 to 16 cm  
**Tensile strength:** TR ≥ 80 kPa  
**Termok8 system fire reaction class:**  
B-s1,d0

panel en resina fenólica expandida  
rígida

Panel aislante en espuma de resina fenólica expandida (PF), idóneo para la aplicación por capas SATE, con altas prestaciones de aislamiento térmico, revestido por las dos caras con velo de vidrio saturado. Homologado según UNI EN 13166.

**Para sistema:** Termok8 Fenólico  
**Medidas:** 120 x 60 cm (para placas de 2 y 3 cm medidas de la placa 120x120 cm)  
**Espesor:** de 2 a 16 cm  
**Resistencia a la tracción:** TR ≥ 80 kPa  
**Clase de reacción al fuego del sistema**  
**Termok8:** B-s1,d0

## tecniche



## certificazioni



## PH 20 king



scheda  
tecnica



data  
sheet



ficha  
técnica



pannello in resina fenolica espansa rigida

Pannello per isolamento termico realizzato in schiuma di resina fenolica espansa (PF), espansa senza l'impiego di CFC o HCFC e HFC, certificato ETICS secondo le linee guida ETAG 004:2013. Certificato in sistema 3 di Valutazione e Verifica della Costanza della Prestazione (VVCP) secondo UNI EN 13166:2016. Rivestito su entrambe le facce con velo vetro saturato.

**Per sistema:** Termok8 Fenolico  
**Formato:** 120 x 40 cm  
**Spessore:** da 2 a 16 cm  
**Resistenza a trazione** TR ≥ 80 kPa  
**Classe reazione fuoco del sistema Termok8:** C-s2,d0

rigid phenolic resin foam panel

Expanded Phenolic resin foam (PF) insulation panel, expanded without the use of CFCs or HCFCs and HFCs, ETICS certified according to the ETAG 004: 2013 guidelines. Certified in system 3 of Evaluation and Verification of Constancy of Performance according to UNI EN 13166: 2016. Covered on both sides with saturated glass veil.

**For the system:** Termok8 Fenolico  
**Size:** 120 x 40 cm  
**Thickness:** from 2 to 16 cm  
**Tensile strength:** TR ≥ 80 kPa  
**Termok8 system fire reaction class:** C-s2,d0

panel en resina fenólica expandida rígida

Panel aislante en espuma de resina fenólica expandida (PF) expandida sin el uso de CFC o HCFC y HFC, certificado SATE según la normativa ETAG 004: 2013. Certificado en el sistema 3 de Evaluación y Verificación de Constancia de Desempeño (VVCP) según UNI EN 13166: 2016. Revestido por ambos lados con velo de vidrio saturado.

**Para sistema:** Termok8 Fenolico  
**Medidas:** 120 x 40 cm  
**Espesor:** da 2 a 16 cm  
**Resistencia a la tracción:** TR ≥ 80 kPa  
**Clase reacción fuoco del sistema Termok8:** C-s2,d0

### tecniche



### certificazioni



## fibra di legno



scheda  
tecnica



data  
sheet



ficha  
técnica



pannello in EPS fibra di legno

Pannello isolante in fibre legno monostrato pressate (WF) idoneo per l'applicazione a cappotto ETICS, intonacabile, rigido, idro-fugo, con prestazioni di isolamento termico, acustico e con elevata diffusività al vapore. Omologato secondo UNI EN 13171. Certificato per la bioedilizia da Natureplus.

**Per sistema:** Termok8 Wood  
**Formato:** 125 x 60 cm  
**Spessore:** da 6 a 20 cm  
**Densità:** 140 kg/m<sup>3</sup>  
**Resistenza a compressione** CS(10) ≥ 100 kPa  
**Resistenza a trazione** TR ≥ 20 kPa

Wood EPS fibreboard panel

Single layer pressed wood fibreboard (WF) insulation panel suitable for ETICS external thermal insulation systems. Can be plastered over. It is stiff, waterproof and provides thermal and acoustic insulation and high vapour diffusivity. Approved according to UNI EN 13171. Certified for green housing by Natureplus.

**For the system:** Termok8 Wood  
**Size:** 125 x 60 cm  
**Thickness:** from 6 to 20 cm  
**Density:** 140 kg/m<sup>3</sup>  
**Compressive strength:** CS(10) ≥ 100 kPa  
**Tensile strength:** TR ≥ 20 kPa

panel en EPS fibra de madera

Panel aislante en fibras de madera en una sola capa prensadas (WF) idóneo para la aplicación por capas SATE, admite enfoscado, rígido, hidrófugo, con prestaciones de aislamiento térmico, acústico y con gran capacidad de difusión del vapor. Homologado según UNI EN 13171. Certificado para eco-arquitectura por Natureplus.

**Para sistema:** Termok8 Wood  
**Medidas:** 125 x 60 cm  
**Espesor:** de 6 a 20 cm  
**Densidad:** 140 kg/m<sup>3</sup>  
**Resistencia a la compresión** CS(10) ≥ 100 kPa  
**Resistencia a la tracción:** TR ≥ 20 kPa

### tecniche



### certificazioni



## aeropan



scheda  
tecnica



data  
sheet



ficha  
técnica



pannello in EPS aerogel per l'isolamento dei ponti termici

Pannello isolante in aerogel, idoneo per l'isolamento di dettagli costruttivi di facciata quali imbotti, loggiati ed intradossi, con sorprendenti prestazioni di isolamento termico. Rivestito, sul lato esterno, con una membrana traspirante in polipropilene armato con fibra di vetro specifico per l'applicazione a cappotto ETICS. Dotato di omologazione ETA 20/0562 secondo EAD 040037-00-1201.

Per isolamento di ponti termici  
**Formato:** 140 x 72 cm  
**Spessore:** da 1 a 6 cm

EPS aerogel panel for insulation of thermal bridges

Aerogel insulation panel, suitable for insulating façade construction details such as soffits, porticos and intrados, providing outstanding thermal insulation. Coated on the outside with a breathable, fibreglass-reinforced polypropylene membrane specifically designed for ETICS external thermal insulation systems. ETA 20/0562-certified according to EAD 040037-00-1201.

For the insulation of thermal bridges  
**Size:** 140 x 72 cm  
**Thickness:** from 1 to 6 cm

panel en EPS aerogel para aislamiento de puentes térmicos

Panel aislante en aerogel, idóneo para el aislamiento de detalles de construcción de fachada, como galerías porticadas y intrados con sorprendentes prestaciones de aislamiento térmico. Revestido, por su lado exterior, con una membrana traspirante en polipropileno armado con fibra de vidrio, específico para la aplicación por capas ETICS. Homologado ETA 20/0562 según EAD 040037-00-1201.

Para aislamiento de puentes térmicos  
**Medidas:** 140 x 72 cm  
**Espesor:** de 1 a 6 cm

### tecniche



### certificazioni



## tassello H2

 scheda  
tecnica

 data  
sheet

 ficha  
técnica

tassello a percussione in HDPE e perno in acciaio zincato galvanizzato	HDPE percussion anchors and galvanised steel pin	taco de percusión en HDPE y perno de acero zincado galvanizado
Tassello universale a percussione con doppia zona di espansione (25/45mm) per calcestruzzo, laterizi pieni e forati, calcestruzzo alleggerito e calcestruzzo cellulare. Piattello telescopico, basculante, sottile e ad alta rigidità. Dotato di omologazione secondo EAD 330196-01-0604.	Universal percussion anchor with double expansion sleeve (25/45 mm) for concrete, solid and hollow brick, lightweight concrete and porous concrete. Telescoping, tilting, thin and highly stiff plate. Certified according to EAD 330196-01-0604.	Taco universal de percusión con doble zona de expansión (25/45 mm) para hormigón, ladrillos macizos y huecos, hormigón aligerado y hormigón celular. Plato telescópico, basculante, fino y de alta rigidez. Homologado según EAD 330196-01-0604.
<b>Diámetro stelo/foro:</b> 8 mm <b>Diámetro piattello:</b> 60 mm <b>Profondità di foratura:</b> 35 mm (55 mm cat. D, E) <b>Profondità di ancoraggio:</b> 25 mm (45 mm cat. D, E) <b>Categorie d'utilizzo ETA:</b> A, B, C, D, E	<b>Shank/Bore Diameter:</b> 8 mm <b>Plate Diameter:</b> 60 mm <b>Drilling Depth:</b> 35 mm (55 mm cat. D, E) <b>Anchoring Depth:</b> 25 mm (45 mm cat. D, E) <b>ETA usage categories:</b> A, B, C, D, E	<b>Diámetro del vástago/agujero:</b> 8 mm <b>Diámetro del plato:</b> 60 mm <b>Profundidad de perforación:</b> 35 mm (55 mm cat. D, E) <b>Profundidad de anclaje:</b> 25 mm (45 mm cat. D, E) <b>Categorías de uso ETA:</b> A, B, C, D, E

tecniche	certificazioni	proprietà	tecnologie

## tassello CT 2G

 scheda  
tecnica

 data  
sheet

 ficha  
técnica

tassello ad avvitamento in HDPE vite in acciaio zincato e galvanizzato	HDPE screw anchor with galvanised steel screw	taco de rosca en HDPE con tornillo de acero zincado y galvanizado
Tassello universale ad avvitamento con zona di espansione in HDPE e vite in acciaio zincato galvanizzato per calcestruzzo, laterizi pieni e forati, calcestruzzo alleggerito e calcestruzzo cellulare per applicazioni a filo e ad incasso. Dotato di omologazione secondo EAD 330196-01-0604.	Universal screw anchor with HDPE expansion sleeve and galvanised steel screw designed for flush and recessed application in concrete, solid and hollow brick, lightweight concrete and porous concrete. Certified according to EAD 330196-01-0604.	Taco universal de rosca con zona de expansión en HDPE y tornillo de acero zincado y galvanizado para hormigón, ladrillos macizos y huecos, hormigón aligerado y hormigón celular para aplicaciones al ras y empotradas. Homologado según EAD 330196-01-0604.
Necessario per Termok8 Modulare e idonei per tutti gli altri <b>Diámetro stelo/foro:</b> 8 mm <b>Diámetro piattello:</b> 60 mm <b>Profondità di ancoraggio:</b> ≥ 25 mm <b>Categorie d'utilizzo ETA:</b> A, B, C, D, E Per montaggio a filo esterno utilizzare "tamponcino in EPS", per montaggio ad incasso utilizzare Copritassello in EPS/Lana di roccia.	For the Termok8 modular system and suitable for all other systems <b>Shank/Bore Diameter:</b> 8 mm <b>Plate Diameter:</b> 60 mm <b>Anchoring depth:</b> ≥ 25 mm <b>ETA usage categories:</b> A, B, C, D, E For flush surface mounting, use "tamponcino in EPS" plug, for recessed use "copritassello in EPS/LANA DI ROCCIA" cap,	Necesario para Termok8 Modular e idoneo para todos los demás sistemas <b>Diámetro del vástago/agujero:</b> 8 mm <b>Diámetro del plato:</b> 60 mm <b>Profundidad de anclaje:</b> ≥ 25 mm <b>Categorías de uso ETA:</b> A, B, C, D, E Para el montaje al ras exterior utilizar el tapón "tamponcino in EPS", para montaje empotrado utilizar el cubretaco "copritassello in EPS/Lana di Roccia"

tecniche	certificazioni	proprietà	tecnologie



## tassello CT L



scheda  
tecnica



data  
sheet



ficha  
técnica



<p>tassello ad avvitamento con vite autofilettante in acciaio zincato galvanizzato</p>	<p>HDPE screw anchor with self-tapping galvanised steel screw</p>	<p>taco de rosca con tornillo autorroscante de acero zincado galvanizado</p>
<p>Tassello universale ad avvitamento con vite autofilettante premontata in acciaio zincato galvanizzato per supporti in legno massiccio, OSB, truciolato e su sottostrutture in acciaio o alluminio fino a 0,75mm per applicazioni a filo e ad incasso. Per montaggio a filo esterno utilizzare "tamponcino in EPS" già compreso nella confezione, o per montaggio ad incasso "copritassello in EPS/Lana di Roccia" acquistabili separatamente. A richiesta "talpa" per pannello isolante.</p>	<p>Universal screw anchor with pre-mounted, self-tapping galvanised steel screw for solid wood, OSB, chipboard and for flush and recessed application in steel or aluminium support structures of up to 0.75 mm thick. For flush surface mounting, use "tamponcino in EPS" plug included in the package or, for recessed mounting, use "copritassello in EPS/Lana di Roccia" cap, available separately. A circular drill bit for insulating panels is available upon request.</p>	<p>Taco universal de rosca con tornillo autorroscante premontado de acero zincado galvanizado para soportes de madera maciza, OSB, aglomerado y sobre subestructuras de acero o aluminio hasta 0,75mm para aplicaciones al ras y empotradas. Para el montaje al ras exterior utilizar el tapón "tamponcino in EPS" ya incluido en el envase; para montaje empotrado utilizar cubretaco "copritassello in EPS/Lana di Roccia", que puede comprarse por separado. Bajo pedido, roseta de fijación para panel aislante.</p>
<p><b>Diametro stelo/foro:</b> 6 mm <b>Diametro piattello:</b> 60 mm <b>Profondità di ancoraggio:</b> 30-40 mm</p>	<p><b>Shank/Bore Diameter:</b> 6 mm <b>Plate Diameter:</b> 60 mm <b>Anchoring Depth:</b> 30-40 mm</p>	<p><b>Diámetro del vástago/agujero:</b> 6 mm <b>Diámetro del plato:</b> 60 mm <b>Profundidad de anclaje:</b> 30-40 mm</p>

tecniche	certificazioni	proprietà	tecnologie

## tassello CT L A2



scheda  
tecnica



data  
sheet



ficha  
técnica



<p>tassello ad avvitamento con vite autofilettante anticorrosione</p>	<p>screw anchor for reduced thickness insulation</p>	<p>taco de rosca para bajos espesores de aislante</p>
<p>Tassello universale ad avvitamento con vite autoforante premontata in acciaio inox anticorrosione per supporti in legno massiccio, OSB, truciolato e su sottostrutture in acciaio o alluminio per applicazioni a filo e ad incasso.</p>	<p>Universal screw-on anchor with pre-assembled self-drilling screw in corrosion-resistant stainless steel for supports in solid wood, OSB, chipboard and on steel or aluminium substructures for flush and recessed applications.</p>	<p>Anclaje atornillable universal con tornillo autotaladrante premontado de acero inoxidable resistente a la corrosión para soportes de madera maciza, OSB, aglomerado y sobre subestructuras de acero o aluminio para aplicaciones enrasadas y empotradas.</p>
<p><b>Diametro stelo/foro:</b> 6 mm <b>Diametro piattello:</b> 60 mm <b>Profondità di ancoraggio:</b> 30-40 mm</p>	<p><b>Rod / hole diameter:</b> 6 mm <b>Plate diameter:</b> 60 mm <b>Anchoring depth:</b> 30-40 mm</p>	<p><b>Diámetro de varilla/agujero:</b> 6 mm <b>Diámetro de la placa:</b> 60 mm <b>Profundidad de anclaje:</b> 30-40 mm</p>

tecniche	certificazioni	proprietà	tecnologie

## tassello CT S1



scheda  
tecnica



data  
sheet



ficha  
técnica



<p>tassello ad avvitamento per spessori di isolante ridotti</p>	<p>screw anchor with corrosion-resistant, self-tapping screw</p>	<p>taco de rosca con tornillo autorroscante anticorrosión</p>
<p>Tassello ad avvitamento con vite in materiale sintetico, specifico per spessori di isolante ridotti tipo AEROGEL o similari, idoneo per calcestruzzo, laterizi pieni e forati, calcestruzzo alleggerito e calcestruzzo cellulare per applicazioni a filo. Montaggio consentito per spessori di isolamento <math>\geq 20</math>mm. Dotato di omologazione secondo EAD 330196-01-0604.</p>	<p>Screwed anchor with screw in synthetic material, specific for reduced thicknesses of insulation such as AIRGEL or similar, suitable for concrete, solid and perforated bricks, lightened concrete and cellular concrete for flush applications. Assembly permitted for insulation thicknesses <math>\geq 20</math>mm. Equipped with approval according to EAD 330196-01-0604.</p>	<p>Anclaje atornillado con tornillo en material sintético, específico para espesores reducidos de aislamiento tipo AIRGEL o similar, apto para hormigón, ladrillo macizo y perforado, hormigón aligerado y hormigón celular para aplicaciones enrasadas. Montaje permitido para espesores de aislamiento <math>\geq 20</math> mm. Equipado con homologación según EAD 330196-01-0604.</p>
<p><b>Diametro stelo/foro:</b> 8 mm <b>Diametro piattello:</b> 60 mm <b>Profondità di ancoraggio:</b> <math>\geq 30</math> mm. categorie d'applicazione A B C D <b>Profondità di ancoraggio:</b> <math>\geq 50</math> mm. categorie d'applicazione E <b>Categorie d'utilizzo ETA:</b> A, B, C,D,E</p>	<p><b>Rod / hole diameter:</b> 8 mm <b>Plate diameter:</b> 60 mm <b>Anchoring depth:</b> <math>\geq 30</math> mm. application categories A B C D <b>Anchoring depth:</b> <math>\geq 50</math> mm. application categories E <b>ETA use categories:</b> A, B, C,D,E</p>	<p><b>Diámetro de varilla/agujero:</b> 8 mm <b>Diámetro de la placa:</b> 60 mm <b>Profundidad de anclaje:</b> <math>\geq 30</math> mm. categorías de aplicación A B C D <b>Profundidad de anclaje:</b> <math>\geq 50</math> mm. categorías de aplicación E <b>Categorías de uso ETA:</b> A, B, C,D, E</p>

tecniche	certificazioni	proprietà	tecnologie

## tassello H3

 scheda  
tecnica

 data  
sheet

 ficha  
técnica

tassello a percussione in hdpe	hdpe percussion anchor	taco de percusión en hdpe
Tassello universale a percussione con zona di espansione in HDPE per cls, laterizio pieno e forato con perno di espansione in PAGF 50 premontato. Piattello telescopico, basculante, sottile e ad alta rigidità. Dotato di omologazione secondo EAD 330196-01-0604.	Universal percussion anchor with HDPE expansion sleeve for concrete, solid brick and hollow brick with pre-installed PAGF 50 expansion pin. Telescoping, tilting, thin and highly stiff plate. Certified according to EAD 330196-01-0604.	Taco universal de percusión con zona de expansión en HDPE para hormigón, ladrillos macizos y ladrillos huecos con perno de expansión en PAGF 50 premontado. lato telescópico, basculante, fino y de alta rigidez. Homologado según EAD 330196-01-0604.
<b>Diametro stelo:</b> 8 mm <b>Diametro piattello:</b> 60 mm <b>Profondità di ancoraggio:</b> ≥ 25 mm <b>Categorie d'utilizzo ETA:</b> A, B, C	<b>Shank Diameter:</b> 8 mm <b>Plate Diameter:</b> 60 mm <b>Anchoring depth</b> ≥ 25 mm <b>ETA usage categories:</b> A, B, C	<b>Diámetro del vástago:</b> 8 mm <b>Diámetro del plato:</b> 60 mm <b>Profundidad de anclaje:</b> ≥ 25 mm <b>Categorías de uso ETA:</b> A, B, C

tecniche	certificazioni	proprietà	tecnologie

## tassello SDK U

 scheda  
tecnica

 data  
sheet

 ficha  
técnica

tassello ad avvitamento per guide Termok8 meccanico o profili di partenza	screw anchor For the Termok8: mechanical system guides or base profiles	taco de rosca para guías Termok8 mecánico o perfiles iniciales
Tassello ad avvitamento (senza piattello) con vite autofilettante premontata in acciaio zincato galvanizzato per il fissaggio di guide orizzontali di sistemi a cappotto ad ancoraggio di tipo meccanico e di profili di partenza su calcestruzzo, laterizi pieni e forati, calcestruzzo alleggerito e calcestruzzo cellulare. Dotato di Certificazione EAD 330196-01-0604	Screw anchor (without plate) with pre-mounted self-tapping screw of galvanised steel for fastening horizontal system guides for mechanically anchored external thermal insulation systems and base profiles on concrete, solid and hollow brick, lightweight concrete and porous concrete. EAD 330196-01-0604 certified	Taco de rosca (sin plato) con tornillo autorroscante premontado de acero zincado galvanizado para la fijación de guías horizontales de sistemas por capas con anclaje de tipo mecánico, así como para perfiles iniciales sobre hormigón, ladrillos macizos y huecos, hormigón aligerado y hormigón celular. Dotado de Certificación EAD 330196-01-0604
<b>Diametro stelo/foro:</b> 8 mm <b>Profondità di ancoraggio:</b> ≥ 25 mm. categorie d'applicazione A B C D <b>Profondità di ancoraggio:</b> ≥ 65 mm. categorie d'applicazione E <b>Categorie d'utilizzo ETA:</b> A, B, C, D, E	<b>Shank/Bore Diameter:</b> 8 mm <b>Anchoring depth</b> ≥ 25 mm. Application categories: A B C D <b>Anchoring depth</b> ≥ 65 mm. Application categories: E <b>ETA usage categories:</b> A, B, C, D, E	<b>Diámetro del vástago/agujero:</b> 8 mm <b>Profundidad de anclaje:</b> ≥ 25 mm, categorías de aplicación: A B C D <b>Profundidad de anclaje:</b> ≥ 65 mm, categoría de aplicación: E <b>Categorías de uso ETA:</b> A, B, C, D, E

tecniche	certificazioni	proprietà	tecnologie

## tassello ND K

 scheda  
tecnica

 data  
sheet

 ficha  
técnica

tassello a percussione per profili di partenza	percussion anchor for base profiles	taco de percusión para perfiles iniciales
Tassello a percussione e ad avvitamento senza piattello per il fissaggio di profili di partenza di sistemi a cappotto ETICS, con vite in acciaio zincato.	Percussion and screw anchor without plate for fastening base profiles of ETICS external thermal insulation systems, with galvanised steel screw.	Taco de percusión y de rosca sin plato para la fijación de perfiles iniciales de sistemas por capas ETICS, con tornillo de acero zincado.
<b>Dimensioni:</b> 6 mm, L=60 mm - 8 mm, L=80 mm <b>Profondità di ancoraggio:</b> ≤30 mm	<b>Size:</b> 6 mm, L =60 mm - 8 mm, L=80 mm <b>Anchoring depth</b> ≤30 mm	<b>Medidas:</b> 6 mm, L=60 mm - 8 mm, L=80 mm <b>Profundidad de anclaje:</b> ≤30 mm

## rondella per lana di roccia VT 2G



rondella aggiuntiva in caso di montaggio ad incasso su lana minerale	additional washer for recessed mounting on mineral wool	arandela adicional en caso de montaje empotrado sobre lana mineral
Rondella utile per ampliare la dimensione del piattello dei tasselli CT 2G, CT L e CT L A2 in caso di applicazione ad incasso su lana minerale a bassa densità o a doppia densità.	Washer used to extend dimensions of CT 2G, CT L and CT L A2 anchor plates for recessed application on low-density or double density mineral wool.	Arandela útil para ampliar el tamaño del plato de los tacos CT 2G, CT L y CT L A2 en caso de aplicación empotrada sobre lana mineral de baja densidad o doble densidad.

tecniche	certificazioni	proprietà	tecnologie

## rondella per lana di roccia 90 mm



rondella aggiuntiva in caso di montaggio a filo su lana minerale	additional washer for flush mounting on mineral wool	arandela adicional en caso de montaje al ras sobre lana mineral
Rondella utile per ampliare la dimensione del piattello dei tasselli CT 2G, CT L e CT L A2 ad un'ampiezza di mm 90 in caso di applicazione a filo su lana minerale a bassa densità.	Washer used to extend dimensions of CT 2G, CT L and CT L A2 anchor plates to a width of 90 mm for application on low-density mineral wool.	Arandela útil para ampliar el tamaño del plato de los tacos CT 2G, CT L y CT L A2 hasta un ancho de 90 mm en caso de aplicación al ras sobre lana mineral de baja densidad.
<b>Dimensioni</b> Ø 90 mm	<b>Size:</b> Ø 90 mm	<b>Medidas</b> Ø 90 mm

tecniche	certificazioni	proprietà	tecnologie

## rondella per lana di roccia 140 mm



rondella aggiuntiva in caso di montaggio a filo su lana minerale	additional washer for flush mounting on mineral wool	arandela adicional en caso de montaje al ras sobre lana mineral
Rondella utile per ampliare la dimensione del piattello dei tasselli CT 2G, CT L e CT L A2 ad un'ampiezza di mm 140 in caso di applicazione a filo su lana di roccia lamellare.	Washer used to extend dimensions of CT 2G, CT L and CT L A2 anchor plates to a width of 140 mm for flush application on laminated rock wool.	Arandela útil para ampliar el tamaño del plato de los tacos CT 2G, CT L y CT L A2 hasta un ancho de 90 mm en caso de aplicación al ras sobre lana de roca laminar.
<b>Dimensioni</b> Ø 140 mm	<b>Size:</b> Ø 140 mm	<b>Medidas</b> Ø 140 mm

tecniche	certificazioni	proprietà	tecnologie

## tappo in EPS per tassello CT 2G - CT L



cilindretti per tasselli CT 2G per montaggio a filo	cylinders for CT 2G anchors -flush mounting	cilindros para montaje de tacos CT 2G
tamponcino di chiusura in polistirolo (EPS) da abbinare ai tasselli CT 2G in caso di montaggio a filo del tassello sul pannello.	polystyrene (EPS) closure pad for use with CT 2G, CT L anchors for flush mounting the anchor on the panel.	tapón de cierre en poliestireno (EPS) para tacos CT 2G, CT L en caso de montaje al ras del taco en el panel.
<b>Dimensioni:</b> L= 14,9 mm	<b>Size</b> L= 14.9 mm	<b>Medidas:</b> L= 14,9 mm

## copritassello



tappo in eps per applicazioni a incasso	eps plug for recessed applications	tapón en eps para aplicaciones empotradas
Tappi di chiusura utilizzati in abbinamento ai tasselli CT 2G, CT L e CT L A2 in caso di montaggio ad incasso.	Plugs for use with CT 2G, CT L and CT L A2 anchors for recessed mounting.	Tapones de cierre utilizados con los tacos CT 2G, CT L y CT L A2 en caso de montaje empotrado.
<b>Diametro:</b> mm 60.	<b>Diameter:</b> 60 mm.	<b>Diámetro:</b> 60 mm.

## spalletta isolante per imbotte lai-sys eps

 scheda  
 tecnica

spalletta isolante prerasata in eps	preskimmed eps insulation reveal	jamba aislante pre-enrasada en eps
<p>Spalletta prefinita LAI-SYS per l'isolamento della spalletta nell'imbotte della finestra. Trattasi di un EPS bianco già rasato con finitura cementizia e paraspigolo già integrato.</p>	<p>Prefinished LAI-SYS reveal for insulation of window intrados reveals. White, preskimmed EPS with cement-based finish and built-in corner bead.</p>	<p>Jamba con acabado previo LAI-SYS para el aislamiento de la jamba en el intradós de la ventana. Se trata de un material EPS blanco ya enrasado con acabado de cemento y protector de aristas ya integrado.</p>
<p><b>Conducibilità termica:</b> <math>\lambda = 0,035</math> W/mK  <b>Spessore:</b> 14 mm  <b>Profondità:</b> 400 mm  <b>Lunghezze disponibili:</b> 1350 - 1600 - 2000 - 2500 mm  <b>N.B.</b> su richiesta anche larghezza 155/195/235/300</p>	<p><b>Thermal conductivity:</b> <math>\lambda = 0.035</math> W/mK  <b>Thickness:</b> 14 mm  <b>Depth:</b> 400 mm  <b>Available lengths:</b> 1350 - 1600 - 2000 - 2500 mm  <b>Note:</b> upon request, widths of 155/195/235/300</p>	<p><b>Conductividad térmica:</b> <math>\lambda = 0,035</math> W/mK  <b>Espesor:</b> 14 mm  <b>Profundidad:</b> 400 mm  <b>Largoes disponibles:</b> 1350 - 1600 - 2000 - 2500 mm  <b>Nota:</b> bajo pedido, también anchos 155/195/235/300</p>

## spalletta isolante per imbotte lai-sys pu

 scheda  
 tecnica

spalletta isolante prerasata in poliuretano	preskimmed polyurethane insulation reveal	jamba aislante pre-enrasada en poliuretano
<p>Spalletta prefinita LAI-SYS per l'isolamento della spalletta nell'imbotte della finestra. Trattasi di un poliuretano già rasato con finitura cementizia e paraspigolo già integrato.</p>	<p>Prefinished LAI-SYS reveal for insulation of window intrados reveals. Preskimmed polyurethane reveal with cement-based finish and built-in corner bead.</p>	<p>Jamba con acabado previo LAI-SYS para el aislamiento de la jamba en el intradós de la ventana. Se trata de un poliuretano ya enrasado con acabado de cemento y protector de aristas ya integrado.</p>
<p><b>Conducibilità termica:</b> <math>\lambda = 0,029</math> W/mK  <b>Spessore:</b> 24 mm  <b>Profondità:</b> 400 mm  <b>Lunghezze disponibili:</b> 1350 - 1600 - 2000 - 2500 mm  <b>N.B.</b> su richiesta anche larghezza 155/195/235/300</p>	<p><b>Thermal conductivity:</b> <math>\lambda = 0.029</math> W/mK  <b>Thickness:</b> 24 mm  <b>Depth:</b> 400 mm  <b>Available lengths:</b> 1350 - 1600 - 2000 - 2500 mm  <b>Note:</b> upon request, widths of 155/195/235/300</p>	<p><b>Conductividad térmica:</b> <math>\lambda = 0,029</math> W/mK  <b>Espesor:</b> 24 mm  <b>Profundidad:</b> 400 mm  <b>Largoes disponibles:</b> 1350 - 1600 - 2000 - 2500 mm  <b>Nota:</b> bajo pedido, también anchos 155/195/235/300</p>

## spalletta isolante per imbotte lai-sys mw

 scheda  
 tecnica

spalletta isolante prerasata in lana di roccia	preskimmed rock wool insulation reveal	jamba aislante pre-enrasada en lana de roca
<p>Spalletta prefinita LAI-SYS per l'isolamento della spalletta nell'imbotte della finestra. Trattasi di lana di roccia già rasata con finitura cementizia e paraspigolo già integrato.</p>	<p>Prefinished LAI-SYS reveal for insulation of window intrados reveals. Preskimmed rock wool reveal with cement-based finish and built-in corner bead.</p>	<p>Jamba con acabado previo LAI-SYS para el aislamiento de la jamba en el intradós de la ventana. Se trata de lana de roca ya enrasada con acabado de cemento y protector de aristas ya integrado.</p>
<p><b>Conducibilità termica:</b> <math>\lambda = 0,037</math> W/mK  <b>Spessore:</b> 24 mm  <b>Profondità:</b> 400 mm  <b>Lunghezze disponibili:</b> 1350 - 1600 - 2000 - 2500 mm  <b>N.B.</b> su richiesta anche larghezza 155/195/235/300</p>	<p><b>Thermal conductivity:</b> <math>\lambda = 0.037</math> W/mK  <b>Thickness:</b> 24 mm  <b>Depth:</b> 400 mm  <b>Available lengths:</b> 1350 - 1600 - 2000 - 2500 mm  <b>Note:</b> upon request, widths of 155/195/235/300</p>	<p><b>Conductividad térmica:</b> <math>\lambda = 0,037</math> W/mK  <b>Espesor:</b> 24 mm  <b>Profundidad:</b> 400 mm  <b>Largoes disponibles:</b> 1350 - 1600 - 2000 - 2500 mm  <b>Nota:</b> bajo pedido, también anchos 155/195/235/300</p>

## profilo di connessione TYP U



scheda  
tecnica



profilo di raccordo spalletta-tapparella	reveal-roller shutter connection profile	perfil de conexión jamba-persiana
<p>Profilo di connessione in alluminio per la protezione della spalletta LAI-SYS in presenza di tapparelle scorrevoli. Da fissare meccanicamente nell'imbotte finestra. Consente di creare una zona portante dove far arrivare in battuta la spalletta Lai-Sys e, al contempo, proteggerla dagli urti meccanici dovuti alla movimentazione della tapparella.</p>	<p>Aluminium connection profile to protect the LAI-SYS reveal when roller shutters are used. To be mechanically fastened to the window intrados. Makes it possible to create a load-bearing area used for flush contact with the Lai-Sys reveal and, at the same time, serves to protect it from the mechanical impacts of shutter movement.</p>	<p>Perfil de conexión en aluminio para la protección de la jamba LAI-SYS en presencia de persianas deslizantes. Para fijar mecánicamente en el intradós de la ventana. Permite crear una zona portante en la que puede hacer tope la jamba Lai-Sys para, además, protegerla de los golpes mecánicos debidos al movimiento de la persiana.</p>
<p><b>Dimensione:</b> sp.14 x 2500 mm sp.24 x 2500 mm</p>	<p><b>Size:</b> th. 14 x 2500 mm th. 24 x 2500 mm</p>	<p><b>Medidas:</b> esp.14 x 2500 mm esp. 24 x 2500 mm</p>

## profilo di connessione PVC U-AL



scheda  
tecnica



profilo di raccordo spalletta-tapparella	reveal-roller shutter connection profile	perfil de conexión jamba-persiana
<p>Profilo di connessione in PVC per la protezione della spalletta LAI-SYS contro serramento o contro il binario a vista della tapparella. Munito di aletta removibile, autoadesivo e verniciabile. Certificato per la tenuta all'aria e all'acqua.</p>	<p>PVC connection profile to protect the LAI-SYS reveal from the roller shutter frame or its visible track. Equipped with removable, self-adhesive and paintable flap. Certified for air and water tightness.</p>	<p>Perfil de conexión en PVC para la protección de la jamba LAI-SYS contra el cierre o contra el riel a la vista de la persiana. Dotado de aleta extraíble, autoadhesivo, admite recubrimiento de pintura. Certificado para el sellado de protección frente al aire y el agua.</p>
<p><b>Spessori disponibili:</b> 14 - 24 mm <b>Lunghezze disponibili:</b> 1350 - 1600 - 2000 mm</p>	<p><b>Available thicknesses:</b> 14 - 24 mm <b>Available lengths:</b> 1350 - 1600 - 2000 mm</p>	<p><b>Espesores disponibles:</b> 14 - 24 mm <b>Largoes disponibles:</b> 1350 - 1600 - 2000 mm</p>



## profilo orizzontale OR/LT



scheda  
tecnica



profili di ancoraggio orizzontali per cappotto meccanico	horizontal anchor profiles for mechanical external thermal insulation system	perfiles de anclaje horizontales para sistema por capas mecánico
<p>Profilo estruso in lega d'alluminio per il fissaggio orizzontale del sistema Termok8 Meccanico atto a sostenere i pannelli EPS Meccanico R ed EPS G Meccanico R appositamente realizzati con scanalature ad incastro. Da fissare meccanicamente mediante tasselli SDK U.</p>	<p>Extruded aluminium alloy profile for horizontal fastening the Termok8 mechanical system to support the specially designed EPS Meccanico R and EPS G Meccanico R panels with interlocking grooves. To be mechanically fastened using SDK U anchors.</p>	<p>Perfil extruido en aleación de aluminio para la fijación horizontal del sistema Termok8 Mecánico, que permite sostener los paneles EPS Meccanico R y EPS G Meccanico R expresamente realizados con ranuras de encaje. Para fijar mecánicamente mediante tacos SDK U.</p>
<p><b>Incidenza:</b> 1,7 m/m<sup>2</sup> <b>Lunghezza barre:</b> 6 m</p>	<p><b>Incidence:</b> 1.7 m/m<sup>2</sup> <b>Bar Length:</b> 6 m</p>	<p><b>Incidencia:</b> 1,7 m/m<sup>2</sup> <b>Largo de las barras:</b> 6 m</p>

## profilo orizzontale PVC OR/LT



scheda  
tecnica



profili di ancoraggio orizzontali per cappotto meccanico	horizontal anchor profiles for mechanical external thermal insulation system	perfiles de anclaje horizontales para sistema por capas mecánico
<p>Profilo in PVC per il fissaggio orizzontale del sistema Termok8 Meccanico atto a sostenere i pannelli EPS Meccanico R ed EPS G Meccanico R appositamente realizzati con scanalature ad incastro. Da fissare meccanicamente mediante tasselli SDK U.</p>	<p>PVC profile for horizontal fastening the Termok8 mechanical system to support the specially designed EPS Meccanico R and EPS G Meccanico R panels with interlocking grooves. To be mechanically fastened using SDK U anchors.</p>	<p>Perfil en PVC para la fijación horizontal del sistema Termok8 Mecánico, que permite sostener los paneles EPS Meccanico R y EPS G Meccanico R, expresamente realizados con ranuras de encaje. Para fijar mecánicamente mediante tacos SDK U.</p>
<p><b>Per sistema:</b> Termok8 Meccanico <b>Lunghezza:</b> 2,5 m <b>Confezione:</b> 20 pezzi = 50 m</p>	<p><b>For the system:</b> Termok8 Meccanico (mechanical) <b>Length:</b> 2.5 m <b>Package:</b> 20 pieces = 50 m</p>	<p><b>Para sistema:</b> Termok8 Meccanico (mecánico) <b>Largo:</b> 2,5 m <b>Envase:</b> 20 piezas = 50 m</p>

## profilo verticale VR/LT



scheda  
tecnica



elementi di collegamento verticali per cappotto meccanico	vertical connection elements for mechanical external thermal insulation system	elementos de conexión verticales para sistema por capas mecánico
Profilo estruso in lega d'alluminio per il fissaggio verticale del sistema Termok8 Meccanico atto a connettere i pannelli EPS Meccanico R ed EPS G Meccanico R appositamente realizzati con scanalature ad incastro.	Extruded aluminium alloy profile for vertical fastening of the Termok8 mechanical system to connect the specially designed EPS Meccanico R and EPS G Meccanico R panels with interlocking grooves.	Perfil extruido en aleación de aluminio para la fijación vertical del sistema Termok8 Mecánico, que permite sostener los paneles EPS Meccanico R y EPS G Meccanico R, expresamente realizados con ranuras de encaje.
<b>Per sistema Termok8:</b> Meccanico <b>Incidenza:</b> 1,6 m/m <sup>2</sup> <b>Lunghezza barre:</b> 6 m	<b>For the Termok8:</b> mechanical system <b>Incidence:</b> 1.6 m/m <sup>2</sup> <b>Bar Length:</b> 6 m	<b>Para sistema:</b> Termok8 Mecánico <b>Incidencia:</b> 1,6 m/m <sup>2</sup> <b>Largo de las barras:</b> 6 m

## profilo verticale PVC VR/LT



scheda  
tecnica



elementi di collegamento verticali per cappotto meccanico	vertical connection elements for mechanical external thermal insulation system	Hydroes elementos de conexión verticales para sistema por capas mecánico malte
Profilo in PVC per il fissaggio verticale del sistema Termok8 Meccanico atto a connettere i pannelli EPS Meccanico R ed EPS G Meccanico R appositamente realizzati con scanalature ad incastro.	PVC profile for vertical fastening of the Termok8 mechanical system to connect the specially designed EPS Meccanico R and EPS G Meccanico R panels with interlocking grooves.	Perfil en PVC para la fijación vertical del sistema Termok8 Mecánico, que permite sostener los paneles EPS Meccanico R y EPS G Meccanico R expresamente realizados con ranuras de encaje.
<b>Per sistema Termok8:</b> Meccanico <b>Lunghezza:</b> 47 cm <b>Confezione:</b> 100 pezzi = 47 m	<b>For the Termok8:</b> mechanical system <b>Length:</b> 47 cm <b>Package:</b> 100 pieces = 47 m	<b>Para sistema:</b> Termok8 Mecánico <b>Largo:</b> 47 cm <b>Envase:</b> 100 piezas = 47 m

## profilo di base



profilo di partenza in alluminio	base profile in aluminium	perfil inicial en aluminio
<p>Profilo di partenza ad U in alluminio naturale antialcalino o alluminio preverniciato, con gocciolatoio, per l'allineamento di partenza, la protezione ed il contenimento del sistema. Si consiglia l'uso del profilo "Rompigoccia per base di partenza" per evitare il rischio di cavillature nell'area della zoccolatura. Adatto a tutti i sistemi di isolamento termico.</p>	<p>U-shaped base profile in natural, anti-alkaline or pre-painted aluminium, with drip profile, for setting-out, protection and retention of the system. We recommend using the "Drip edge for base profile" profile to prevent the risk of cracking in the area around the building plinth. Suitable for all z thermal insulation systems.</p>	<p>Perfil inicial en U en aluminio natural antialcalino o aluminio prepintado, con gotero, para la alineación inicial, la protección y la contención del sistema. Se aconseja el uso del perfil "Rompegotas para base inicial" para evitar el riesgo de cuarteados en el área del rodapié. Idóneo para todos los sistemas de aislamiento térmico IVAS.</p>
<p><b>Perisolanti di spessore:</b> da 3, a 16 cm (altri su richiesta)</p> <p><b>Lunghezza barre:</b> 2,5 m</p> <p><b>Confezione:</b> da 10 barre (tot 25 m)</p>	<p><b>For insulation thicknesses:</b> from 3 to 16 cm (others available upon request)</p> <p><b>Bar Length:</b> 2.5 m</p> <p><b>Package:</b> 10 bars (total: 25 m)</p>	<p><b>Para aislantes de espesor:</b> de 3 hasta 16 cm (otros bajo pedido)</p> <p><b>Largo de las barras:</b> 2,5 m</p> <p><b>Envase:</b> de 10 barras (tot 25 m)</p>

## profilo di base PVC-R



profilo di partenza in pvc con elemento di chiusura	pvc base profile with closing element	perfil inicial en pvc con elemento de cierre
<p>Profilo di partenza ad L in pvc a taglio termico abbinato con un raccordo di chiusura variabile, provvisto di gocciolatoio, rete di risvolto ed elemento di connessione per ridurre il pericolo di cavillature nell'area della zoccolatura. Il profilo ad L di partenza, viene fornito in due misure per poter coprire isolamenti di spessore variabile da 10 a 24 cm. Adatto a tutti i sistemi di isolamento termico IVAS.</p>	<p>L-shaped PVC base thermal break profile combined with variable end fitting, equipped with a drip profile, mesh side and connection element to reduce the risk of cracking in the area of the building plinth. The L-shaped base profile comes in two sizes to cover insulation thicknesses ranging from 8 to 24 cm. Suitable for all IVAS thermal insulation systems.</p>	<p>Perfil inicial en L en pvc de corte térmico con unión de cierre variable, dotado de gotero, malla remetida y elemento de conexión para reducir el peligro de cuarteados en el área del rodapié. El perfil inicial en L se entrega en dos medidas para poder cubrir aislamientos de espesor variable de 8 a 24 cm. Idóneo para todos los sistemas de aislamiento térmico IVAS.</p>
<p><b>Lunghezza barre:</b> 2 m</p> <p><b>Confezione:</b> da 10 barre (tot 20 m)</p>	<p><b>Bar Length:</b> 2 m</p> <p><b>Package:</b> 10 bars (total: 20 m)</p>	<p><b>Largo de las barras:</b> 2 m</p> <p><b>Envase:</b> de 10 barras (tot 20 m)</p>

 scheda  
 tecnica

## rompigoccia per base di partenza-R

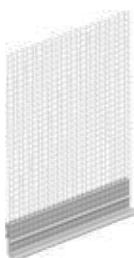

profilo di raccordo con il profilo di partenza	connection profile with the base profile	perfil de conexión con el perfil inicial
<p>Profilo in PVC con gocciolatoio e rete in fibra di vetro termosaldata per aggancio al profilo di base partenza. Riduce il pericolo di cavillature del rivestimento nella congiunzione dei profili di base-partenza.</p>	<p>PVC profile with drip edge and heat-sealed glass fibre mesh for bonding to the base profile. Reduces the risk of cracks in the coating at base profiles' connection points.</p>	<p>Perfil en PVC con gotero y malla en fibra de vidrio termosellada para el enganche al perfil de base inicial. Reduce el peligro de cuarteados del revestimiento en la unión de los perfiles de base-inicio.</p>
<p><b>Lunghezza barre:</b> 2 m</p> <p><b>Confezione:</b> 25 barre (tot 50 m)</p>	<p><b>Bar Length:</b> 2 m</p> <p><b>Package:</b> 25 bars (total: 50 m)</p>	<p><b>Largo de las barras:</b> 2 m</p> <p><b>Envase:</b> 25 barras (tot 50 m)</p>

 scheda  
 tecnica

## paraspigolo angolare AL



profilo angolare di protezione in alluminio	aluminium corner bead profile	perfil angular de protección en aluminio
<p>Profilo angolare in alluminio per il rinforzo e la protezione di tutti gli angoli, spigoli e stipiti ad angolo retto di finestre o porte.</p>	<p>Aluminium corner bead profile to reinforce and protect all corners, edges and right-angled window or door jambs.</p>	<p>Perfil angular en aluminio para el refuerzo y la protección de todos los ángulos, aristas y marcos en ángulo recto de ventanas o puertas.</p>
<p><b>Lunghezza barre:</b> 2,5 m</p> <p><b>Confezione:</b> da 50 barre (tot 125 m)</p>	<p><b>Bar Length:</b> 2.5 m</p> <p><b>Package:</b> 50 bars (total: 125 m)</p>	<p><b>Largo de las barras:</b> 2,5 m</p> <p><b>Envase:</b> de 50 barras (tot 125 m)</p>

## paraspigolo angolare AL-R



scheda  
tecnica

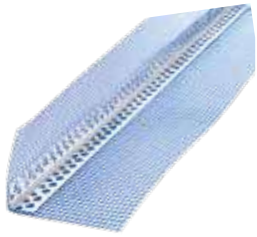

profilo angolare di protezione in alluminio con rete	aluminium corner bead profile with mesh	perfil angular de protección en aluminio con malla
Profilo angolare in alluminio per il rinforzo e la protezione di tutti gli angoli, spigoli e stipiti ad angolo retto di finestre o porte con rete in fibra di vetro incorporata.	Aluminium corner bead profile with built-in glass fibre mesh designed to reinforce and protect all corners, edges and right-angled window or door jambs.	Perfil angular en aluminio para el refuerzo y la protección de todos los ángulos, aristas y marcos en ángulo recto de ventanas o puertas con malla de fibra de vidrio incorporada.
<b>Misura barre:</b> 8 cm x 12 cm x 2,5 m <b>Confezione:</b> da 50 barre (tot 125 m)	<b>Bar sizes:</b> 8 cm x 12 cm x 2,5 m <b>Package:</b> 50 bars (total: 125 m)	<b>Medidas de las barras:</b> 8 cm x 12 cm x 2,5 m <b>Envase:</b> de 50 barras (tot 125 m)

## paraspigolo angolare PVC



profilo angolare di protezione in pvc	pvc corner bead profile	perfil angular de protección en pvc
Profilo angolare in PVC per il rinforzo e la protezione di tutti gli angoli, spigoli e stipiti ad angolo retto di finestre o porte.	PVC corner bead profile to reinforce and protect all corners, edges and right-angled window or door jambs.	Perfil angular en PVC para el refuerzo y la protección de todos los ángulos, aristas y marcos en ángulo recto de ventanas o puertas.
<b>Lunghezza barre:</b> 2,5 m <b>Confezione:</b> da 50 barre (tot 125 m)	<b>Bar Length:</b> 2.5 m <b>Package:</b> 50 bars (total: 125 m)	<b>Largo de las barras:</b> 2,5 m <b>Envase:</b> de 50 barras (tot 125 m)

## paraspigolo angolare PVC-R



scheda  
tecnica



profilo angolare di protezione in pvc con rete	pvc corner bead profile with mesh	perfil angular de protección en pvc con malla
Profilo angolare in PVC per il rinforzo e la protezione di tutti gli angoli, spigoli e stipiti ad angolo retto di finestre o porte con rete in fibra di vetro incorporata.	PVC corner bead profile with built-in glass fibre mesh designed to reinforce and protect all corners, edges and right-angled window or door jambs.	Perfil angular en PVC para el refuerzo y la protección de todos los ángulos, aristas y marcos en ángulo recto de ventanas o puertas con malla de fibra de vidrio incorporada.
<b>Lunghezza barre:</b> 2,5 m <b>Altezza lati angolare:</b> 22 x 22mm <b>Altezza rete:</b> 80x120mm <b>Confezione:</b> da 50 barre (tot 125 m) Su richiesta altre dimensioni fino a 300mm	<b>Bar Length:</b> 2.5 m <b>Profile sides height:</b> 22 x 22mm <b>Mesh height:</b> 80x120mm <b>Package:</b> 50 bars (total: 125 m) Other sizes of up to 300mm available upon request	<b>Largo de las barras:</b> 2,5 m <b>Altura de los lados del angular:</b> 22x22 mm <b>Altura de la malla:</b> 80X120 mm <b>Envase:</b> de 50 barras (tot 125 m) Bajo pedido, otras medidas hasta 300 mm

## paraspigolo angolare archi PVC



profilo angolare di protezione archi in pvc	pvc corner bead profile for archways	perfil angular de protección de arcos en pvc
Profilo angolare in PVC per il rinforzo e la protezione di tutti gli archi. Flessibile e modellabile.	PVC corner bead profile to reinforce and protect all archways. Flexible and mouldable.	Perfil angular en PVC para el refuerzo y protección de todos los arcos. Flexible y modelable.
<b>Lunghezza barre:</b> 3 m	<b>Bar Length:</b> 3 m	<b>Largo de las barras:</b> 3 m

## paraspigolo angolare flex PVC-R



profilo angolare di protezione in pvc ad angolo variabile	pvc corner bead profile with variable angle	perfil angular de protección en pvc en ángulo variable
Profilo angolare in PVC a rotolo, per il rinforzo e la protezione di tutti gli angoli, spigoli e stipiti ad angolo variabile di finestre o porte con rete in fibra di vetro incorporata.	Roll of PVC corner bead profile with built-in glass fibre mesh designed to reinforce and protect all corners, edges and variable-angled window or door jambs.	Perfil angular en PVC en rollo, para el refuerzo y protección de todos los ángulos, aristas y marcos en ángulo variable de ventanas o puertas con malla en fibra de vidrio incorporada.
<b>Lunghezza rotolo:</b> 25 m (1 rotolo in una scatola)	<b>Roll Length:</b> 25 m (1 roll in a box)	<b>Largo del rollo:</b> 25 m (1 rollo en una caja)

## profilo con gocciolatoio PVC-R

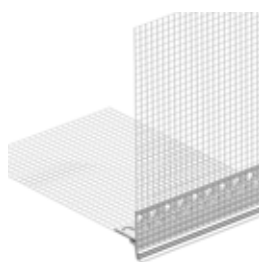

profilo angolare con gocciolatoio e rete	corner bead profile with drip edge and mesh	perfil angular con gotero y malla
Profilo in PVC con rete in fibra di vetro incorporata e gocciolatoio per l'esecuzione di angoli su facciate rientranti, solai su spazi aperti (piani Pilotys), vani finestre e porte, cassette per avvolgibili, balconi ecc.	PVC profile with built-in glass fibre mesh and drip edge designed to prepare corners on recessed façades, floors in open spaces (Pilotys floors), window and door openings, roller shutter boxes, balconies etc.	Perfil en PVC con malla en fibra de vidrio incorporada y gotero para la ejecución de ángulos en fachadas entrantes, forjados en espacios abiertos (plantas bajas diáfanos con pilares), huecos de ventanas y puertas, cajas para enrollables, balcones, etc.
<b>Lunghezza barre:</b> 2,5 m <b>Confezione:</b> da 25 barre (tot 62,5 m)	<b>Bar Length:</b> 2.5 m <b>Package:</b> 25 bars (total: 62.5 m)	<b>Largo de las barras:</b> 2,5 m <b>Envase:</b> de 25 barras (tot 62,5 m)

## profilo SD sottodavanzale

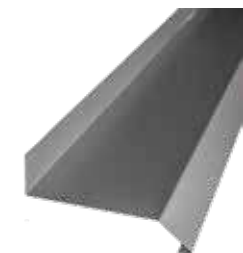

profilo in alluminio sottodavanzale	aluminium undersill profile	perfil en aluminio para debajo del alféizar
Profilato in lega d'alluminio naturale, antialcalino, per la chiusura e la protezione meccanica del sistema Termok8 sotto i davanzali esistenti. Dotato di gocciolatoio. Sovraverniciabile.	Profile in antialkaline, natural aluminium alloy designed for closure and mechanical protection of Termok8 insulation systems under existing window sills. Equipped with drip edge. It can be overpainted.	Perfil en aleación de aluminio natural, antialcalino, para cierre y protección mecánica del sistema Termok8 bajo los alféizares existentes. Dotado de gotero. Admite recubrimiento con pintura.
<b>Lunghezza barre:</b> 2,5 m <b>Eventuale confezione:</b> 10 barre (totale 25 m)	<b>Bar Length:</b> 2.5 m <b>Package:</b> 10 bars (total: 25 m)	<b>Largo de las barras:</b> 2,5 m <b>Envase</b> (en su caso): 10 barras (total 25 m)

## profilo finestre PVC-R



profilo di raccordo a finestra con rete	window connection profile with mesh	perfil de conexión a ventana con malla
Profilo autoadesivo in PVC per il collegamento del sistema ai telai dei serramenti, preaccoppiato con rete in fibra di vetro incorporata.	Self-adhesive PVC profile pre-coupled with glass fibre mesh for connecting the system to window and door frames.	Perfil autoadhesivo en PVC para la conexión del sistema a los bastidores de los cierres, prelamado con malla en fibra de vidrio incorporada.
<b>Lunghezza barre:</b> 2,4 m <b>Confezione:</b> da 30 barre (tot 72 m)	<b>Bar Length:</b> 2.4 m <b>Package:</b> 30 bars (total: 72 m)	<b>Largo de las barras:</b> 2,4 m <b>Envase:</b> de 30 barras (tot 72 m)

 scheda  
 tecnica



## profilo finestre plus PVC-R



scheda  
tecnica



profilo di raccordo a finestra con rete	window connection profile with mesh	perfil de conexión a ventana con malla
<p>Profilo in PVC per il raccordo a tenuta d'acqua battente tra il sistema a cappotto e i telai dei serramenti, in classe 1, con nastro autoadesivo, guarnizione sigillante in PE e rete in fibra di vetro termosaldada. Dotato di una guarnizione flessibile per la compensazione di piccoli movimenti (monodimensionali).</p>	<p>PVC profile for watertight connection between external thermal insulation systems and window and door frames, class 1, with self-adhesive tape, PE seal and heat-sealed glass fibre mesh. Equipped with a flexible seal to compensate for minor (one-dimensional) movements.</p>	<p>Perfil en PVC para unión estanca a la incidencia de la lluvia entre el sistema por capas y los bastidores de los cierres, en clase 1, con cinta autoadhesiva, junta de sellado en PE y malla en fibra de vidrio termosellada. Dotado de una junta flexible para compensar pequeños movimientos (monodimensionales).</p>
<p><b>Lunghezza barre:</b> 2,4 m <b>Confezione:</b> da 30 barre (tot 72 m)</p>	<p><b>Bar Length:</b> 2.4 m <b>Package:</b> 30 bars (total: 72 m)</p>	<p><b>Largo de las barras:</b> 2,4 m <b>Envase:</b> de 30 barras (tot 72 m)</p>

## profilo finestre plus 3d PVC-R



scheda  
tecnica



profilo di raccordo a finestra con rete	window connection profile with mesh	perfil de conexión a ventana con malla
<p>Profilo in PVC per il raccordo a tenuta d'acqua battente tra il sistema a cappotto e i telai dei serramenti, in classe 3, con nastro autoadesivo, guarnizione sigillante in PE e rete in fibra di vetro termosaldada. Dotato di una guarnizione flessibile per la compensazione di grandi movimenti (tridimensionali)</p>	<p>PVC profile for watertight connection between external thermal insulation systems and window and door frames, class 3, with self-adhesive tape, PE seal and heat-sealed glass fibre mesh. Equipped with a flexible seal to compensate for large (three-dimensional) movements</p>	<p>Perfil en PVC para unión estanca a la incidencia de la lluvia entre el sistema por capas y los bastidores de los cierres, en clase 3, con cinta autoadhesiva, junta de sellado en PE y malla en fibra de vidrio termosellada. Dotado de una junta flexible para compensar grandes movimientos (tridimensionales)</p>
<p><b>Lunghezza barre:</b> 2,4 m <b>Confezione:</b> da 25 barre (tot 60 m)</p>	<p><b>Bar Length:</b> 2.4 m <b>Package:</b> 25 bars (total: 60 m)</p>	<p><b>Largo de las barras:</b> 2,4 m <b>Envase:</b> de 25 barras (tot 60 m)</p>

## terminale per sottotetto PVC-R



scheda  
tecnica



profilo di raccordo al sottotetto	profile for connection to roofing beam structure	perfil de conexión al desván
<p>Profilo di collegamento del sistema alla struttura del sottotetto, per garantire l'aerazione del sottotetto o la ventilazione del tetto ventilato, realizzato con un corpo rigido parainsetti in PVC e rete in fibra di vetro termosaldada.</p>	<p>Profile connecting the system to the roofing beam structure, to ensure ventilation of the roofing beam structure or ventilated roof, made of a rigid, insect-resistant PVC body and heat-sealed glass fibre mesh.</p>	<p>Perfil de conexión del sistema a la estructura del desván, para garantizar la ventilación de este o la ventilación del techo ventilado, realizado con un cuerpo rígido antiinsectos en PVC y malla en fibra de vidrio termosellada.</p>
<p><b>Misure:</b> 5,5x200 cm <b>Eventuale confezione:</b> 25 barre (50 m)</p>	<p><b>Size:</b> 5.5x200 cm <b>Package:</b> 25 bars (total: 50 m)</p>	<p><b>Medidas:</b> 5,5x200 cm <b>Envase</b> (en su caso): 25 barras (50 m)</p>

## profilo di collegamento PVC-R



scheda  
tecnica



profilo di raccordo a lamiera	profile for connection to sheet metal	perfil de conexión a chapa
<p>Profilo in PVC per il raccordo del sistema con scossaline, davanzali o altri elementi metallici, preaccoppiato con rete in fibra di vetro. Il profilo è dotato di un grembiule flessibile utile a consentire i movimenti differenziali degli elementi metallici collegati al sistema di isolamento a cappotto, garantendo un collegamento elastico ed una tenuta impermeabile fra intonaco e parti in lamiera.</p>	<p>PVC profile pre-coupled with glass fibre mesh designed to connect the system to flashings, window sills, or other metal elements. The profile is equipped with a flexible apron to allow differential movements of the metal elements connected to the external thermal insulation system, guaranteeing an elastic connection and an impermeable seal between plaster and sheet metal parts.</p>	<p>Perfil en PVC para la unión del sistema con cubrejuntas, alféizares u otros elementos metálicos, prelaminado con malla de fibra de vidrio. El perfil está dotado de un elemento flexible útil para permitir los movimientos diferenciales de los elementos metálicos conectados al sistema de aislamiento por capas, garantizando así una conexión elástica y un ajuste impermeable entre enfoscado y piezas de chapa.</p>
<p><b>Lunghezza barre:</b> 2 m <b>Confezione:</b> da 25 barre (tot 50 m)</p>	<p><b>Bar Length:</b> 2 m <b>Package:</b> 25 bars (total: 50 m)</p>	<p><b>Largo de las barras:</b> 2 m <b>Envase:</b> de 25 barras (tot 50 m)</p>

 scheda  
 tecnica

## profilo di chiusura PVC-R

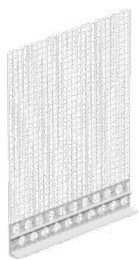

profilo di chiusura per rivestimenti di finitura a spessore	closing profile for thick finishing coats	perfil de cierre para revestimientos de acabado de espesor
Il profilo di chiusura in PVC con rete permette di eseguire perfette chiusure di rivestimenti su sistemi di isolamento. Per un'interruzione a vista del sistema a cappotto, o per realizzare dei cambi di colore precisi e lineari.	The PVC closing profile with mesh ensures perfect closure of coatings on insulation systems. For a visible break in the external thermal insulation system or for precise, linear changes in colour.	El perfil de cierre en PVC con malla permite realizar cierres perfectos de los revestimientos sobre sistemas de aislamiento. Para una interrupción a la vista del sistema por capas, o para realizar cambios de color precisos y lineales.
<b>Lunghezza barre:</b> 2m <b>Spessori disponibili:</b> 3 mm, 6 mm, 8 mm, 10 mm <b>Confezione:</b> 25 pezzi (tot. 50 m) <b>Altezza rete:</b> 125 mm <b>Grammatura rete:</b> 160 g/m <sup>2</sup>	<b>Bar Length:</b> 2m <b>Available thicknesses:</b> 3 mm, 6 mm, 8 mm, 10 mm <b>Package:</b> 25 pieces (total 50 m) <b>Mesh height:</b> 125 mm <b>Mesh Weight:</b> 160 g/m <sup>2</sup>	<b>Largo de las barras:</b> 2m <b>Espesores disponibles:</b> 3 mm, 6 mm, 8 mm, 10 mm <b>Envase:</b> 25 piezas (tot. 50 m) <b>Altura de la malla:</b> 125 mm <b>Gramaje de la malla:</b> 160 g/m <sup>2</sup>

## profilo CO di contenimento



profilo di chiusura del sistema a cappotto	closing profile for external thermal insulation system	perfil de cierre del sistema por capas
Profilato in lega d'alluminio naturale, antialcalino, per la chiusura laterale e la protezione meccanica del sistema Termok8. Sovraverificabile.	Antialkaline, natural aluminium alloy profile for side closing and mechanical protection of the Termok8 insulation system. It can be overpainted.	Perfil en aleación de aluminio natural, antialcalino, para el cierre lateral y la protección mecánica del sistema Termok8. Admite recubrimiento con pintura.
<b>Lunghezza barre:</b> 2,5 m <b>Eventuale confezione:</b> 10 barre (totale 25 m)	<b>Bar Length:</b> 2.5 m <b>Package:</b> 10 bars (total: 25 m)	<b>Largo de las barras:</b> 2,5 m <b>Envase (en su caso):</b> 10 barras (total 25 m)

## profilo C di colmo



profilo in alluminio chiusura giunto di separazione orizzontale	aluminium closing profile for horizontal separation joints	perfil en aluminio de cierre de junta de separación horizontal
Profilato in lega d'alluminio naturale, antialcalino, per la chiusura del giunto di separazione orizzontale del sistema Termok8 modulare big, nonché della tenuta d'acqua battente dello stesso. Obbligatorio nel sistema di Termok8 Modular Big. Spessore in funzione dell'isolante. Sovraverificabile.	Antialkaline, natural aluminium alloy profile for closing horizontal separation joints in the Termok8 modular big system and ensuring its water tightness. Required in the Termok8 Modular Big system. Thickness depending on insulation. It can be overpainted.	Profilado en aleación de aluminio natural, antialcalino, para el cierre de la junta de separación horizontal del sistema Termok8 modulare big, así como del sello estanco contra la incidencia de la lluvia. Obligatorio en el sistema de Termok8 Modular Big. Espesor en función del aislante. Admite recubrimiento con pintura.
<b>Lunghezza barre:</b> 2,5 m <b>Eventuale confezione:</b> 10 barre (totale 25 m)	<b>Bar Length:</b> 2.5 m <b>Package:</b> 10 bars (total: 25 m)	<b>Largo de las barras:</b> 2,5 m <b>Envase (en su caso):</b> 10 barras (total 25 m)

## profilo per rivestimenti modulari



profilo in alluminio a L di chiusuragiunto di separazione orizzontale	aluminium L-shaped closing profile for horizontal separation joints	perfil en aluminio en L de cierre de junta de separación horizontal
Profilato a "L" in lega d'alluminio naturale, antialcalino, per l'interruzione del sistema e la distribuzione dei carichi con rivestimenti modulari di piccole dimensioni. Obbligatorio nei sistemi di TermoK8 Modular D e TermoK8 Facciavista. Spessore in funzione dell'isolante. Sovraverniciabile.	L-shaped profile in antialkaline, natural aluminium alloy, designed for creating gaps in the system and to distribute the loads with small modular cladding. Required in the TermoK8 Modular D and TermoK8 Facciavista systems. Thickness depending on insulation. It can be overpainted.	Perfilado en "L" en aleación de aluminio natural, antialcalino, para la interrupción del sistema y la distribución de las cargas con revestimientos modulares de pequeño tamaño. Obligatorio en los sistemas de TermoK8 Modular D y TermoK8 Facciavista. Espesor en función del aislante. Admite recubrimiento con pintura.
<b>Lunghezza barre:</b> 2,5 m	<b>Bar Length:</b> 2.5 m	<b>Largo de las barras:</b> 2,5 m

## nastro autoespandente sigillante BG1



scheda  
tecnica



nastro di guarnizione di interfaccia tra cappotto ed elementi	tape for interfacing seals between insulation system and elements	cinta para junta de interfaz entre sistema por capas y elementos
Nastro sigillante per giunti, autoadesivo, pre-compresso e pre-impregnato che soddisfa lo standard BG1. Sigillatura a tenuta stagna contro la pioggia battente $\geq 600$ Pa di tutti i giunti di raccordo tra sistema di isolamento e finestre, davanzali, travi in legno etc, in edifici nuovi o ristrutturati. Permeabile al vapore, resistente ai raggi UV con eccellenti proprietà termiche e acustiche. Può essere esposto direttamente agli agenti atmosferici. Realizzato in PU espanso.	Self-adhesive, pre-compressed and pre-impregnated joint sealing tape compliant with BG1 standard. Waterproof sealing against driving rain $\geq 600$ Pa for all joints between the insulation system and windows and doors, window sills, wooden beams etc. Ideal for both new or renovated buildings. Vapour permeable, UV-resistant with excellent thermal and acoustic properties. Can be directly exposed to the weather. Made of PU foam.	Cinta selladora para juntas, autoadhesiva, precomprimida y preimpregnada que cumple con el estándar BG1. Sellado estanco contra la incidencia de la lluvia a $\geq 600$ Pa de todas las juntas de unión entre sistema de aislamiento y ventanas, alféizares, vigas de madera, etc., en edificios nuevos o reacondicionados. Permeable al vapor, resistente a los rayos UV con excelentes propiedades térmicas y acústicas. Puede exponerse directamente a los agentes atmosféricos. Realizado en PU expandido.
<b>Colore</b> nero. <b>Misure rotolo:</b> larghezza 15 mm; lunghezza 12 m <b>Spessore:</b> 2,0-6,0 mm Campo d'impiego: larghezza fuga 2 - 6 mm <b>Misure rotolo:</b> larghezza 15 mm; lunghezza 8 m <b>Spessore:</b> 6,0-15,0 mm <b>Campo d'impiego:</b> larghezza fuga 6-15 mm	<b>Color:</b> black. <b>Roll Size:</b> width 15 mm; length 12 m <b>Thickness:</b> 2.0-6.0 mm Usage range: joint widths of 2 - 6 mm <b>Roll Size:</b> width 15 mm; length 8 m <b>Thickness:</b> 6.0-15.0 mm <b>Usage range:</b> joint widths of 6 - 15 mm	<b>Color</b> negro. <b>Medidas del rollo:</b> ancho 15 mm, largo 12 m <b>Espesor:</b> 2,0-6,0 mm Campo de empleo: ancho de la junta 2 - 6 mm <b>Medidas del rollo:</b> ancho 15 mm, largo 8 m <b>Espesor:</b> 6,0-15,0 mm <b>Campo de empleo:</b> ancho de la junta 6 - 15 mm



scheda  
tecnica

## rete fuga decorativa

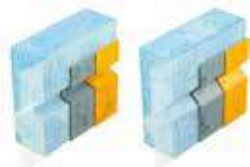

rete di armatura presagomata lineare per decori in facciata	shaped linear reinforcement mesh for façade decorations	mallà de armadura preformada lineal para decoraciones en fachada
Rete di vetro apprettata, antidemagliante, resistente agli alcali, pre-sagomata per l'esecuzione di scanalature orizzontali o verticali su intonaco e su pannelli isolanti con fuga predisposta.	Sized, unravel-proof mesh resistant to alkalis, shaped for making horizontal or vertical grooves in plaster and insulating panels with prepared joints.	Malla de vidrio aprestada, antidesmallante, resistente a los álcalis, preformada para la ejecución de acanaladuras horizontales o verticales en enfoscados y sobre paneles aislantes con junta preparada previamente.
<b>Tipo 1</b> (trapezio stretta): 30x20x17 mm <b>Tipo 2</b> (trapezio larga): 37x20x17 mm <b>Tipo 3</b> (triangolare): 30x0x17 mm <b>Lunghezza profilo:</b> 200 cm <b>Confezione:</b> 10 pezzi	<b>Type 1:</b> 30x20x17 mm <b>Type 2:</b> 37x20x17 mm <b>Type 3:</b> 30x0x17 mm <b>Profile Length:</b> 200 cm <b>Package:</b> 10 pieces	<b>Tipo 1:</b> 30x20x17 mm <b>Tipo 2:</b> 37x20x17 mm <b>Tipo 3:</b> 30x0x17 mm <b>Largo del perfil:</b> 200 cm <b>Envase:</b> 10 piezas

## rete fuga decorativa angolo esterno



rete di armatura presagomata al angolo esterno per decori in facciata	shaped reinforcement mesh for outer façade corner decorations	mallà de armadura preformada en el ángulo exterior para decoraciones de fachada
Rete di vetro apprettata, antidemagliante, resistente agli alcali, presagomata per l'esecuzione di scanalature ad angolo esterno su intonaco e su pannelli isolanti con fuga predisposta.	Sized, unravel-proof mesh resistant to alkalis, shaped for making outer corner grooves in plaster and insulating panels with prepared joints.	Malla de vidrio aprestada, antidesmallante, resistente a los álcalis, preformada para la ejecución de acanaladuras de ángulo externo en enfoscados y sobre paneles aislantes con junta preparada previamente.
<b>Tipo 1</b> (trapezoidale stretta) 30x20x17mm <b>Tipo 2</b> (trapezoidale larga) 37x20x17mm <b>Tipo 3</b> (triangolare) 30x0x17mm <b>Confezione:</b> 10 pz	<b>Type 1:</b> 30x20x17 mm <b>Type 2:</b> 37x20x17 mm <b>Type 3:</b> 30x0x17 mm <b>Package:</b> 10 pcs	<b>Tipo 1:</b> 30x20x17 mm <b>Tipo 2:</b> 37x20x17 mm <b>Tipo 3:</b> 30x0x17 mm <b>Envase:</b> 10 piezas

## rete fuga decorativa angolo interno



rete di armatura presagomata ad angolo interno per decori in facciata	shaped reinforcement mesh for internal façade corner decorations	mallà de armadura preformada de ángulo interior para decoraciones en fachada
Rete di vetro apprettata, antidemagliante, resistente agli alcali, presagomata per l'esecuzione di scanalature ad angolo interno su intonaco e su pannelli isolanti con fuga predisposta.	Sized, unravel-proof mesh resistant to alkalis, shaped for making internal corner grooves in plaster and insulating panels with prepared joints.	Hidroe Malla de vidrio aprestada, antidesmallante, resistente a los álcalis, preformada para la ejecución de acanaladuras en ángulo interior sobre enfoscados y sobre paneles aislantes con junta preparada previamente.
<b>Tipo 1</b> (trapezio stretta) 30x20x17mm <b>Tipo 2</b> (trapezio larga) 37x20x17mm <b>Tipo 3</b> (triangolo) 30x0x17mm <b>Confezione:</b> 10 pz	<b>Type 1:</b> 30x20x17 mm <b>Type 2:</b> 37x20x17 mm <b>Type 3:</b> 30x0x17 mm <b>Package:</b> 10 pcs	<b>Tipo 1:</b> 30x20x17 mm <b>Tipo 2:</b> 37x20x17 mm <b>Tipo 3:</b> 30x0x17 mm <b>Envase:</b> 10 piezas

## profilo di giunto semplice GL-R



scheda  
tecnica



profilo giunto di dilatazione lineare	corner expansion joint profile	perfil junta de dilatación angular
<p>Profilo per giunti di dilatazione su superfici piane (180°) sul sistema di isolamento termico, realizzato con nastro di tenuta flessibile, preaccoppiato con rete in fibra di vetro. Per ampiezze massime del giunto di 5-25 mm. Con possibilità di acquisto dell'elemento di copertura estetico.</p>	<p>Profile for expansion joints on orthogonal surfaces (90°) on thermal insulation systems, made of flexible sealing tape, pre-coupled with glass fibre mesh. For maximum joint widths of 5-25 mm. Aesthetic covering element available.</p>	<p>Perfil para juntas de dilatación sobre superficies ortogonales (90°) en el sistema de aislamiento térmico, realizado con cinta de ajuste flexible, prelaminado con malla de fibra de vidrio. Para anchuras máximas de la junta de 5-25 mm. Con posibilidad de compra del elemento de cobertura estético.</p>
<p><b>Lunghezza barre:</b> 2,5 m <b>Eventuale confezione:</b> 25 barre (tot. 62,5 m)</p>	<p><b>Bar Length:</b> 2.5 m <b>Package:</b> 25 bars (total: 62.5 m)</p>	<p><b>Largo de las barras:</b> 2,5 m <b>Envase</b> (en su caso): 25 barras (total 62,5 m)</p>

## profilo di giunto semplice GA-R



scheda  
tecnica



profilo giunto di dilatazione angolare	linear expansion joint profile	perfil junta de dilatación lineal
<p>Profilo per giunti di dilatazione su superfici ortogonali (90°) sul sistema di isolamento termico, realizzato con nastro di tenuta flessibile, preaccoppiato con rete in fibra di vetro. Per ampiezze massime del giunto di 5-25 mm. Con possibilità di acquisto dell'elemento di copertura estetico.</p>	<p>Profile for expansion joints on flat surfaces (180°) on thermal insulation systems, made of flexible sealing tape, pre-coupled with glass fibre mesh. For maximum joint widths of 5-25 mm. Aesthetic covering element available.</p>	<p>Perfil para juntas de dilatación sobre superficies planas (180°) en el sistema de aislamiento térmico, realizado con cinta de ajuste flexible, prelaminado con malla de fibra de vidrio. Para anchuras máximas de la junta de 5-25 mm. Con posibilidad de compra del elemento de cobertura estético.</p>
<p><b>Lunghezza barre:</b> 2,5 m <b>Eventuale confezione:</b> 25 barre (tot. 62,5 m)</p>	<p><b>Bar Length:</b> 2.5 m <b>Package:</b> 25 bars (total: 62.5 m)</p>	<p><b>Largo de las barras:</b> 2,5 m <b>Envase</b> (en su caso): 25 barras (total 62,5 m)</p>

## giunto di dilatazione plus PVC-R



scheda  
tecnica

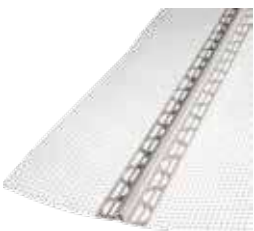

profilo di giunto di dilatazione di piccoli movimenti	expansion joint profile for minor movements	perfil de junta de dilatación de pequeños movimientos
<p>Profilo giunto di dilatazione in PVC per garantire il contenimento di piccoli movimenti, realizzato con coprigiunto centrale e rete in fibra di vetro termosaldata. Favorisce l'assorbimento dei movimenti strutturali di assestamento nelle pareti continue. Utilizzato anche come raccordo tra i pannelli isolanti di diversa natura/tipologia. Funge anche da guida per la posa dell'intonaco e/o per l'applicazione di guaine liquide. Idoneo per raccordare il sistema a cappotto con rasature armate o per l'interruzione di rasatura armata e finitura.</p>	<p>PVC expansion joint profile to ensure containment of minor movements, made with central joint cover and heat-sealed glass fibre mesh. Helps absorb structural settling movements in curtain walls. Also used as connection between different types of insulation panels. Also serves as guide when laying plaster and/or liquid membranes. Suitable for connecting the external thermal insulation system with reinforced skim coats or for interrupting reinforced skim and topcoats.</p>	<p>Perfil junta de dilatación en PVC para garantizar la contención de pequeños movimientos, realizado con tapajunta central y malla de fibra de vidrio termosoldada. Favorece la absorción de los movimientos estructurales de ajuste en las paredes continuas. También se utiliza como conexión entre los paneles aislantes de diferente naturaleza/tipo. También sirve de guía para la colocación del yeso y/o para la aplicación de fundas líquidas. Apto para conectar el sistema a capa con afeitados armados o para la interrupción del afeitado armado y acabado.</p>
<p><b>Lunghezza barre:</b> 2,5 m <b>Eventuale confezione:</b> 25 barre (tot. 62,5 m)</p>	<p><b>Size:</b> height 7 mm, length 2.5 m <b>Package:</b> 25 bars (total: 62.5 m)</p>	<p><b>Medidas:</b> altura 7 mm, largo 2,5 m <b>Envase</b> (en su caso): 25 barras (62,5 m)</p>



## kit montaggio profili di base



set per il fissaggio dei profili di partenza e guide	set for fastening base profiles and joints	set para la fijación de los perfiles iniciales y guías
Set per il montaggio idoneo al fissaggio di profili di partenza in sistemi ETICS	installation set suitable for fastening base profiles on ETICS systems	Set de montaje idóneo para la fijación de los perfiles iniciales en sistemas SATE
<b>Composto da:</b> 75 tasselli a percussione ND-K 6 x 60 10 elementi di giunzione PV 30 50 elementi di compensazione AS 3	<b>Composed of:</b> 75 percussion anchors ND-K 6 x 60 10 joint elements PV 30 50 compensation elements AS 3	<b>Formado por:</b> 75 tacos de percusión ND-K 6 x 60 10 elementos de unión PV 30 50 elementos de compensación AS 3

## elementi di compensazione



distanziatori per profili di partenza e guide	spacers for base profiles and guides	separadores para perfiles iniciales y guías
Per la compensazione delle tolleranze di planarità della facciata nel montaggio dei profili di partenza o delle guide per i sistemi meccanici. Adattabili a diversi diametri di tassello ed accoppiabili per coprire le più svariate tolleranze. Ciascuno spessore ha una colorazione differente per un rapido riconoscimento in cantiere.	To compensate for tolerance in façade flatness during installation of base profiles or mechanical system guides. Can be adapted for various anchor diameters and coupled to cover a wide range of tolerances. To ensure easy recognition at the construction site, each thickness has a different colour.	Para la compensación de las tolerancias de planicidad de la fachada en el montaje de los perfiles de inicio o de las guías para los sistemas mecánicos. Adaptables a distintos diámetros de taco y acoplables para cubrir las más diversas tolerancias. Cada espesor tiene un color distinto para su rápido reconocimiento en obra.

## tassello di ancoraggio a spirale

 scheda  
 tecnica

tassello di ancoraggio di carichi leggeri a cappotto ultimato	anchor for light loads after external thermal insulation system has been completed	taco de anclaje de cargas ligeras al sistema por capas terminado
Tassello in plastica a forma di spirale, con rondella di tenuta e alloggiamento interno filettato per una vite, per l'ancoraggio di oggetti leggeri su sistemi ETICS già intonacati (indipendente dallo spessore di isolamento), senza formazione di ponte termico.	Spiral-shaped plastic anchor with sealing washer and threaded inner housing for a screw, used to anchor lightweight objects on previously plastered ETICS systems (of any insulation thickness), without forming a thermal bridge.	Taco de plástico en forma de espiral, con arandela de ajuste y alojamiento interior roscado para un tornillo, para anclaje de objetos ligeros en sistemas ETICS ya enfoscados (independiente del espesor de aislamiento), sin formación de puente térmico.
<b>Esempi di applicazione:</b> numeri civici, casette postali piccole, lampade, punti luce, insegne leggere ecc. <b>Portata consigliata:</b> 5 kg <b>Contenuto 1 scatola:</b> 100 pezzi	<b>Examples of Applications:</b> house numbers, small mailboxes, lamps, spotlights, light-weight signs, etc. <b>Recommended Weight:</b> 5 kg <b>Contents in 1 box:</b> 100 pieces	<b>Ejemplos de Aplicaciones:</b> números urbanos, buzones postales pequeños, lámparas, puntos de luz, rótulos ligeros, etc. <b>Capacidad aconsejada:</b> 5 kg <b>Contenido 1 caja:</b> 100 piezas

## inserto dart-set



scheda  
tecnica



<p>set fissaggio di carichi leggeri-medi a cappotto ultimato</p>	<p>set for fastening light and medium-weight loads after external thermal insulation system has been completed</p>	<p>set de fijación de cargas ligeras-medias a sistema por capas terminado</p>
<p>Elemento di fissaggio costituito da una boccia di montaggio in materiale plastico con guarnizione di tenuta in EPDM ed un tassello per facciata (Ø 8mm). Utilizzato per il montaggio di carichi non pianificati da leggeri a medi su sistemi ETICS già intonacati in EPS, lana minerale, senza formazione di ponte termico.</p>	<p>Fixing element consisting of a plastic mounting bush with EPDM sealing gasket and a dowel for the facade (Ø 8mm). Used for mounting light to medium unplanned loads on ETICS systems already plastered in EPS, mineral wool, without forming a thermal bridge.</p>	<p>Elemento de fijación compuesto por un casquillo de montaje de plástico con junta de estanqueidad de EPDM y un taco para la fachada (Ø 8 mm). Se utiliza para el montaje de cargas no planificadas de ligeras a medias sobre sistemas SATE ya revestidos de EPS, lana mineral, sin formar puente térmico.</p>
<p><b>Portata consigliata:</b> 15 kg <b>Diametro foro:</b> 8 mm <b>Profondità foratura:</b> 80 mm <b>Azionamento:</b> Torx T30 <b>Applicazione:</b> staffe pluviali, ganci fermaimposte, cassette postali, lampade, punti luce, insegne, rilevatori di movimento ecc. <b>Contenuto del kit:</b> 10 Boccole - 10 Guarnizioni - 10 inserti per Ø 6 mm - 10 tasselli per facciata diametro 8 mm - 1 bit di montaggio</p>	<p><b>Recommended load:</b> 15 kg <b>Hole diameter:</b> 8 mm <b>Drilling depth:</b> 80 mm <b>Drive:</b> Torx T30 <b>Application:</b> rain brackets, shutter hooks, mailboxes, lamps, lights, signs, motion detectors, etc. <b>Kit contents:</b> 10 Bushings - 10 Gaskets - 10 inserts for Ø 6 mm - 10 dowels for facade diameter 8 mm - 1 mounting bit</p>	<p><b>Capacidad aconsejada:</b> 15 kg <b>Diámetro del orificio:</b> 8 mm <b>Profundidad de perforación:</b> 80 mm <b>Accionamiento:</b> Torx T30 <b>Aplicación:</b> soportes de lluvia, ganchos de persianas, buzones, lámparas, luces, letreiros, detectores de movimiento, etc. <b>Contenido del kit:</b> 10 casquillos - 10 juntas - 10 insertos para Ø 6 mm - 10 tacos para fachada Ø 8 mm - 1 punta de montaje</p>

## iso-bar



scheda  
tecnica



<p>barra di fissaggio di carichi medi-pesanti a cappotto ultimato</p>	<p>fastening bar for medium to heavy loads after the external thermal insulation system has been completed</p>	<p>barra de fijación de cargas medias-pesadas a sistema por capas terminado</p>
<p>Barra in fibra di vetro con perno di montaggio in acciaio inox per il montaggio pianificato o non pianificato di carichi pesanti su sistemi ETICS già intonacati, senza formazione di ponte termico. Barra in fibra di vetro selezionabile a misura direttamente in cantiere. Certificazione dei valori di carico e di trasmittanza termica.</p>	<p>Glass fibre bar with stainless steel installation pin for both planned and unplanned installation of heavy loads on previously plastered ETICS systems without creating thermal bridges. Glass fibre bar, can be custom sized direCT Ly on site. Certification of load and thermal transmittance values.</p>	<p>Barra en fibra de vidrio con perno de montaje en acero inox para el montaje planificado o no planificado de cargas pesadas en sistemas ETICS ya enfoscados, sin formación de puente térmico. Barra en fibra de vidrio seleccionable a medida directamente en obra. Certificación de los valores de carga y de transmitancia térmica.</p>
<p><b>Applicazione:</b> tende da sole, pensiline, climatizzatori, insegne, antenne paraboliche ecc. <b>Contenuto del kit:</b> 1 Iso-Bar, 1 boccia per il montaggio, 1 rondella con guarnizione di tenuta in EPDM, 1 dado M12 per il fissaggio di carico.</p>	<p><b>Examples of Applications:</b> awnings, canopies, air conditioners, signs, satellite dishes, etc. <b>Contents of the kit:</b> 1 Iso-Bar, 1 installation bush, 1 washer with EPDM seal, 1 M12 nut to fasten load.</p>	<p><b>Ejemplos de Aplicaciones:</b> toldos, marquesinas, climatizadores, rótulos, antenas parabólicas, etc. <b>Contenido del kit:</b> 1 Iso-Bar, 1 casquillo para el montaje, 1 arandela conjunta de ajuste en EPDM, 1 tuerca M12 para la fijación de carga.</p>

## cassetta elettrica Eldoline EPS

 scheda  
 tecnica

elemento in eps per il posizionamento di interruttori e punto luce	eps element for positioning switches and spotlights	elemento en eps para la colocación de interruptores y puntos de luz
<p>Cassetta elettrica isolante, costituita da una scatola e da quattro piedini realizzati in poliammide, applicati in uno stampato in EPS, idonea per il fissaggio sicuro dei componenti elettrici. Le alimentazioni cavi o tubi sono chiuse con dei tappini ciechi in EPS. Permette una installazione integrata al sistema ETICS facile ed efficiente. Garantisce l'assenza di ponte termico e la tenuta all'aria. Testate anche per il Blower Door Test.</p>	<p>Insulated electrical box, composed of a box and four polyamide feet, applied in moulded EPS unit suitable for safe securing of electrical components. The power supply cables or ducts are sealed with EPS blind plugs. Enables easy, efficient installation integrated with the ETICS system. Ensures that there are no thermal bridges and guarantees airtightness. Also tested for the Blower Door Test.</p>	<p>Caja eléctrica aislante, constituida por una caja y cuatro patas realizadas en poliamida, aplicadas en una estampación en EPS, idónea para la fijación segura de los componentes eléctricos. Las alimentaciones, cables o tubos, se cierran con tapones ciegos en EPS. Permite una instalación integrada en el sistema ETICS fácil y eficiente. Garantiza la ausencia de puente térmico y la estanqueidad al aire. Probadas también para el Blower Door Test.</p>
<p><b>Spessori disponibili:</b> 80 - 300 mm  <b>Dimensioni:</b> 150 x 150 mm  <b>Peso specifico EPS:</b> 30 kg/m<sup>3</sup>  <b>Inserto:</b> Vimark 503 - V71303  <b>Resistenza al fuoco:</b> GW 650 °C  <b>Conducibilità termica:</b> = 0,031 W/mK</p>	<p><b>Available thicknesses:</b> 80 - 300 mm  <b>Size:</b> 150 x 150 mm  <b>EPS Specific Weight:</b> 30 kg/m<sup>3</sup>  <b>Insert:</b> Vimark 503 - V71303  <b>Fire resistance:</b> GW 650 °C  <b>Thermal conductivity:</b> = 0,031 W/mK</p>	<p><b>Espesores disponibles:</b> 80 - 300 mm  <b>Medidas:</b> 150 x 150 mm  <b>Peso específico EPS:</b> 30 kg/m<sup>3</sup>  <b>Inserto:</b> Vimark 503 - V71303  <b>Resistencia al fuego:</b> GW 650 °C  <b>Conductividad térmica:</b> = 0,031 W/mK</p>

## inserto di rinforzo Quadroline

 scheda  
 tecnica

cubo di montaggio in eps per l'applicazione di carichi medi	eps mounting cube for applying medium loads	cubo de montaje en eps para la aplicación de cargas medias
<p>Cubo di fissaggio in EPS ad alta densità per il fissaggio di carichi leggeri e medi nei sistemi ETICS senza formazione di ponte termico. Funge inoltre da spessore di appoggio in caso di carichi intermedi.</p>	<p>Fastening cube made of high density EPS for fastening light and medium loads in ETICS systems without forming a thermal bridge. It also acts as a support shim for intermediate loads.</p>	<p>Cubo de fijación en EPS de alta densidad para la fijación de cargas ligeras y medias en los sistemas ETICS sin formación de puente térmico. Hace además de espesor de apoyo en caso de cargas intermedias.</p>
<p><b>Spessori disponibili:</b> 60 - 300 mm  <b>Dimensione:</b> 100 x 100 mm  <b>Peso specifico:</b> 170 kg/m<sup>3</sup>  <b>Conducibilità termica:</b> = 0,051 W/mK  <b>Portata consigliata:</b> 15 kg per elemento  <b>Applicazioni:</b> gronde, luci da esterno, allarmi, telecamere, etc...            Certificazione dei valori di carico e di trasmittanza.</p>	<p><b>Available thicknesses:</b> 60 - 300 mm  <b>Size:</b> 100 x 100 mm  <b>Specific Weight:</b> 170 kg/m<sup>3</sup>  <b>Thermal conductivity:</b> = 0,051 W/mK  <b>Recommended weight:</b> 15 kg per element  <b>Applications:</b> gutters, outdoor lights, alarms, cameras, etc...            Certification of load and transmittance values.</p>	<p><b>Espesores disponibles:</b> 60 - 300 mm  <b>Medidas:</b> 100 x 100 mm  <b>Peso específico:</b> 170 kg/m<sup>3</sup>  <b>Conductividad térmica:</b> = 0,051 W/mK  <b>Capacidad aconsejada:</b> 15 kg por elemento  <b>Aplicaciones:</b> canaletas, luces de exterior, alarmas, cámaras de vídeo, etc...            Certificación de los valores de carga y de transmitancia.</p>

## barra di fissaggio Vari Q

 scheda  
 tecnica

barra sezionabile in eps per l'applicazione di carichi medi	eps bar, divisible in sections, for applying medium loads	barra seccionable en eps para la aplicación de cargas medias
<p>Barra di fissaggio in EPS sezionabile multi spessore ad alta densità per il fissaggio di carichi leggeri e medi nei sistemi ETICS senza formazione di ponte termico. Funge inoltre da spessore di appoggio in caso di carichi intermedi.</p>	<p>Divisible, multi-thickness fastening bar of high-density EPS for fastening light and medium-weight loads in ETICS systems without forming a thermal bridge. It also acts as a support shim for intermediate loads.</p>	<p>Barra de fijación en EPS seccionable, multiespesor de alta densidad para la fijación de cargas ligeras y medias en los sistemas ETICS sin formación de puente térmico. Hace además de espesor de apoyo en caso de cargas intermedias.</p>
<p><b>Dimensione:</b> 100 x 100 x 1000 mm  <b>Peso specifico:</b> 140 kg/m<sup>3</sup>  <b>Conducibilità termica:</b> = 0,047 W/mK  <b>Portata consigliata:</b> 15 kg per elemento  <b>Applicazioni:</b> gronde, luci da esterno, allarmi, telecamere, etc...            Certificazione dei valori di carico e di trasmittanza.</p>	<p><b>Size:</b> 100 x 100 x 1000 mm  <b>Specific Weight:</b> 140 kg/m<sup>3</sup>  <b>Thermal conductivity:</b> = 0,047 W/mK  <b>Recommended weight:</b> 15 kg per element  <b>Applications:</b> gutters, outdoor lights, alarms, cameras, etc...            Certification of load and transmittance values.</p>	<p><b>Medidas:</b> 100 x 100 x 1000 mm  <b>Peso específico:</b> 140 kg/m<sup>3</sup>  <b>Conductividad térmica:</b> = 0,047 W/mK  <b>Capacidad aconsejada:</b> 15 kg por elemento  <b>Aplicaciones:</b> canaletas, luces de exterior, alarmas, cámaras de vídeo, etc...            Certificación de los valores de carga y de transmitancia.</p>

## supporto di fissaggio K1-PE



scheda  
tecnica



<p>elemento di fissaggio di cardini e inferriate</p>	<p>fastening element for awnings, shelters and canopies</p>	<p>elemento de fijación de toldos, marquesinas y tejadillos</p>
<p>Elemento di fissaggio ad angolo in poliuretano con armatura in fibra di vetro e piedini di regolazione per il fissaggio di cardini/inferriate sui sistemi ETICS senza formazione di ponte termico.</p>	<p>Rectangular polyurethane plate with steel, aluminium and phenolic resin reinforcement for fastening very heavy loads in ETICS systems without forming a thermal bridge.</p>	<p>Placa rectangular en poliuretano con armadura en acero, aluminio y resina fenólica para la fijación en los sistemas SATE de cargas muy pesadas sin formación de puente térmico.</p>
<p><b>Dimensione:</b> 240 x 125 mm <b>Superficie utile:</b> 108 x 48 mm <b>Peso specifico:</b> 350 kg/m<sup>3</sup> <b>Portata consigliata:</b> 35 kg per elemento <b>Applicazioni:</b> cardini, persiane scorrevoli, inferriate Certificazione dei valori di carico e di trasmittanza.</p>	<p><b>Dimension:</b> 240 x 125 mm <b>Useful surface:</b> 108 x 48 mm <b>Specific weight:</b> 350 kg / m<sup>3</sup> <b>Recommended load:</b> 35 kg per element <b>Applications:</b> hinges, sliding shutters, railings Certification of load and transmittance values.</p>	<p><b>Dimensión:</b> 240 x 125 mm <b>Superficie útil:</b> 108 x 48 mm <b>Peso específico:</b> 350 kg/m<sup>3</sup> <b>Carga recomendada:</b> 35 kg por elemento <b>Aplicaciones:</b> bisagras, contraventanas correderas, barandillas Certificación de valores de carga y transmitancia.</p>

## piastra per carichi pesanti UMP-ALU-TR



scheda  
tecnica



<p>elemento di fissaggio di tende da sole, pensiline e tettoie</p>	<p>fastening element for hinges and gratings</p>	<p>elemento de fijación de goznes y rejas</p>
<p>Piastra rettangolare in poliuretano con armatura in acciaio, alluminio e resina fenolica per il fissaggio nei sistemi ETICS di carichi molto pesanti senza formazione di ponte termico.</p>	<p>Polyurethane corner fastening element with glass fibre reinforcement and adjusting feet for fastening hinges/gratings on ETICS systems without forming a thermal bridge.</p>	<p>Elemento de fijación en ángulo en poliuretano con armadura en fibra de vidrio y patas de ajuste para la fijación de goznes/rejas en sistemas SATE sin formación de puente térmico.</p>
<p><b>Spessori disponibili:</b> 80 - 300 mm <b>Dimensione:</b> 238 x 138 mm <b>Superficie utile:</b> 162 x 80 mm <b>Peso specifico:</b> 350 kg/m<sup>3</sup> <b>Portata consigliata:</b> 900 kg per elemento Certificazione dei valori di carico e di trasmittanza.</p>	<p><b>Available thicknesses:</b> 80 - 300 mm <b>Dimension:</b> 238 x 138 mm <b>Useful surface:</b> 162 x 80 mm <b>Specific weight:</b> 350 kg / m<sup>3</sup> <b>Recommended load:</b> 900 kg per element Certification of load and transmittance values.</p>	<p><b>Espesores disponibles:</b> 80 - 300 mm <b>Dimensión:</b> 238 x 138 mm <b>Superficie útil:</b> 162 x 80 mm <b>Peso específico:</b> 350 kg / m<sup>3</sup> <b>Carga recomendada:</b> 900 kg por elemento Certificación de valores de carga y transmitancia.</p>

tecniche	certificazioni	proprietà	tecnologie

## supporto di fissaggio frontale TRA-WIK-ALU-RF



scheda  
tecnica



<p>elemento di fissaggio frontale di cardini inferriate e parapetti</p>	<p>frontal fastening element for hinges, gratings and parapets</p>	<p>elemento de fijación frontal de goznes, rejas y parapetos</p>
<p>Elementi di fissaggio ad angolo in poliuretano con armatura in acciaio, alluminio e resina fenolica per il fissaggio di cardini/inferriate/parapetti sui sistemi ETICS senza formazione di ponte termico sul fronte facciata.</p>	<p>Polyurethane corner fastening elements with steel, aluminium and phenolic resin reinforcement for fastening hinges/gratings/parapets on ETICS systems without forming a thermal bridge in the façade.</p>	<p>Elemento de fijación en ángulo en poliuretano con armadura en acero, aluminio y resina fenólica para la fijación de goznes/rejas/parapetos en sistemas SATE sin formación de puente térmico en el frente de fachada.</p>
<p><b>Spessori disponibili:</b> 80 - 300 mm <b>Dimensione:</b> 280 x 125 mm <b>Superficie utile:</b> 97 x 45 mm <b>Peso specifico:</b> 350 kg/m<sup>3</sup> <b>Portata consigliata:</b> 65 kg per elemento <b>Applicazioni:</b> cardini, persiane scorrevoli, inferriate Certificazione dei valori di carico e di trasmittanza.</p>	<p><b>Available thicknesses:</b> 80 - 300 mm <b>Size:</b> 280 x 125 mm <b>Useful surface area:</b> 97 x 45 mm <b>Specific Weight:</b> 350 kg/m<sup>3</sup> <b>Recommended weight:</b> 65 kg per element <b>Applications:</b> hinges, sliding shutters, railings Certification of load and transmittance values.</p>	<p><b>Espesores disponibles:</b> 80 - 300 mm <b>Superficie útil:</b> 97 x 45 mm <b>Peso específico:</b> 350 kg/m<sup>3</sup> <b>Capacidad aconsejada:</b> 65 kg por elemento <b>Aplicaciones:</b> bisagras, contraventanas correderas, barandillas Certificación de los valores de carga y de transmitancia.</p>

tecniche	certificazioni	proprietà	tecnologie

## supporto di fissaggio laterale TRA-WIK-ALU-RL

 scheda  
 tecnica

elemento di fissaggio laterale di cardini inferriate e parapetti	side fastening element for hinges, gratings and parapets	elemento de fijación lateral de goznes, rejas y parapetos
Elementi di fissaggio ad angolo in poliuretano con armatura in acciaio, alluminio e resina fenolica per il fissaggio di inferriate e balconi alla francese sui sistemi ETICS senza formazione di ponte termico in imbotte finestra.	Polyurethane corner fastening elements with steel, aluminium and phenolic resin reinforcement for fastening French windows and balconies on ETICS systems without thermal bridging in the window intrados.	Elementos de fijación en ángulo en poliuretano con armadura en acero, aluminio y resina fenólica para la fijación de rejas y balcones franceses en sistemas ETICS sin formación de puente térmico en el intradós de la ventana.
<b>Spessori disponibili:</b> 80 – 300 mm <b>Dimensione:</b> 280 x 125 mm <b>Superficie utile:</b> 97 x 45 mm <b>Peso specifico:</b> 350 kg/m <sup>3</sup> <b>Portata consigliata:</b> 65 kg per elemento <b>Resistenza in spinta:</b> 200 Kg/ml in spinta secondo la norma per parapetti. <b>Applicazioni:</b> parapetti, cardini in imbotte, inferriate Certificazione dei valori di carico e di trasmittanza.	<b>Available thicknesses:</b> 80 – 300 mm <b>Size:</b> 280 x 125 mm <b>Useful surface area:</b> 97 x 45 mm <b>Specific weight:</b> 350 kg/m <sup>3</sup> <b>Recommended weight:</b> 65 kg per element <b>Thrust resistance:</b> 200 kg/ml in thrust according to the standard for parapets. <b>Applications:</b> parapets, hinges in intrados, railings Certification of load and transmittance values.	<b>Espesores disponibles:</b> 80 – 300 mm <b>Medidas:</b> 280 x 125 mm <b>Superficie útil:</b> 97 x 45 mm <b>Peso específico:</b> 350 kg/m <sup>3</sup> <b>Capacidad aconsejada:</b> 65 kg por elemento <b>Resistencia en empuje:</b> 200 Kg/ml en empuje según la norma para parapetos. <b>Aplicaciones:</b> antepechos, bisagras en intradós, barandillas Certificación de los valores de carga y de transmitancia.

tecniche	certificazioni	proprietà	tecnologie

## iso-corner

 scheda  
 tecnica

elemento di fissaggio di cardini e inferriate	fastening element for hinges and gratings	elemento de fijación de goznes y rejas
Consolle ad angolo in poliuretano ad alta densità, per il montaggio pianificato di carichi pesanti su sistemi ETICS senza formazione di ponte termico sul fronte facciata o in imbotte finestra. Selezionabile a misura direttamente in cantiere (anche in posa).	Corner console made of high-density polyurethane, for the planned installation of heavy loads on ETICS systems without forming a thermal bridge on the façade or in the window intrados. Can be selected to size direCT Ly on site (also on installation).	Consolas en ángulo en poliuretano de alta densidad, para el montaje planificado de cargas pensadas en sistemas ETICS sin formación de puente térmico en el frente de la fachada o en el intradós de la ventana. Seleccionable a medida directamente en obra (también en colocación).
<b>Dimensione:</b> 270 x 142,5 mm <b>Superficie utile facciata:</b> 100 x 10mm <b>Superficie utile spalletta:</b> 100 x Spessore Isocorner - 40mm <b>Spessori disponibili:</b> 14, 20, 30 cm <b>Applicazioni:</b> parapetti, cardini in imbotte, persiane scorrevoli, inferriate. Certificazione dei valori di carico	<b>Size:</b> 270 x 142.5 mm <b>Useful surface area of the façade:</b> 100 x 10mm <b>Useful surface area of the reveal:</b> 100 x Isocorner thickness - 40mm <b>Available thicknesses:</b> 14, 20, 30 cm <b>Applications:</b> parapets, hinges in intrados, sliding shutters, gratings. Certification of load values	<b>Medidas:</b> 270 x 142,5 mm <b>Superficie útil de fachada:</b> 100 x 10mm <b>Superficie útil de la jamba:</b> 100 x Espesor Isocorner - 40mm <b>Espesores disponibles:</b> 14, 20, 30 cm <b>Aplicaciones:</b> parapetos, goznes en intradós, persianas deslizantes, rejas. Certificación de los valores de carga

tecniche	certificazioni	proprietà	tecnologie



## iso-corner kit SDF



scheda  
tecnica



tasselli di fissaggio iso-corner su supporti A, B, C, D	iso-corner anchors on A, B, C, D substrates	tacos de fijación iso-corner sobre soportes A, B, C, D
Set di tasselli per fissaggio su supporti in calcestruzzo (A), muratura piena (B), forata (C) o calcestruzzo alleggerito (D). Zona di espansione ottimizzata per una perfetta tenuta anche su materiali più problematici. Espansione radiale per una maggiore sicurezza di ancoraggio. Superficie della vite priva di cromo esavalente Cr(VI). Doppia alettatura di sicurezza antitorsione per un montaggio più sicuro	Set of dowels for fastening to concrete (A), solid masonry (B), perforated masonry (C) or lightweight concrete (D). Optimised expansion zone for perfect sealing even on the most problematic materials. Radial expansion for greater anchorage security. Screw surface free of hexavalent chromium Cr(VI). Double anti-twist safety fins for safer mounting	Set de tacos para fijación en soportes de hormigón (A), paredes de ladrillo macizo (B), perforado (C) u hormigón aligerado (D). Zona de expansión optimizada para un perfecto ajuste incluso en los materiales más problemáticos. Expansión radial para una mayor seguridad de anclaje. Superficie del tornillo libre de cromo hexavalente Cr(VI). Sistema de dobles aletas de seguridad anti-torsión para un montaje más seguro
<b>Profondità di foratura:</b> ≥ 80 mm <b>Profondità di ancoraggio:</b> ≥ 70 mm <b>Diametro foratura:</b> 10 mm	<b>Drilling depth</b> ≥ 80 mm <b>Anchoring depth</b> ≥ 70 mm <b>Drilling Diameter:</b> 10 mm	<b>Profundidad de perforación:</b> ≥ 80 mm <b>Profundidad de anclaje:</b> ≥ 70 mm <b>Diámetro de perforación:</b> 10 mm

tecniche	certificazioni	proprietà	tecnologie

## iso-corner kit SDP



scheda  
tecnica



tasselli di fissaggio iso-corner su supporti E	anchors for fastening iso-corner on E substrates	tacos de fijación iso-corner sobre soportes E
Set di tasselli per fissaggio su supporti in CLS cellulare (E). Tasselli da facciata con vite a doppio diametro. Ancoraggio sicuro grazie alla zona di espansione combinata. Elevata capacità di carico.	Set of dowels for fastening on cellular concrete substrates (E). Façade anchors with double-diameter screw. Safe anchoring thanks to the combined expansion zone. High load capacity.	Set de tacos para fijación sobre soportes en CLS celular (E). Tacos de fachada con tornillo de doble diámetro. Anclaje seguro gracias a la zona de expansión combinada. Alta capacidad de carga.
<b>Profondità di foratura:</b> ≥ 80 mm <b>Profondità di ancoraggio:</b> ≥ 70 mm <b>Diametro foratura:</b> 10 mm	<b>Drilling depth</b> ≥ 80 mm <b>Anchoring depth</b> ≥ 70 mm <b>Drilling Diameter:</b> 10 mm	<b>Profundidad de perforación:</b> ≥ 80 mm <b>Profundidad de anclaje:</b> ≥ 70 mm <b>Diámetro de perforación:</b> 10 mm

tecniche	certificazioni	proprietà	tecnologie

## davanzali GFB

 scheda  
 tecnica

davanzale isolante prefinito	pre-finished insulating sill	alféizar aislante con acabado previo
<p>Davanzale isolante in GFB (cemento rinforzato in fibra di vetro) accoppiato con EPS ad alta densità 30 kg/m<sup>3</sup>, atto ad eliminare ponti termici in corrispondenza delle soglie delle finestre. Finitura verniciabile in cantiere. Utilizzabile sia su nuove costruzioni che ristrutturazioni.</p>	<p>GFB (glass-fibre reinforced concrete) insulating window sill coupled with 30 kg/m<sup>3</sup> high density EPS, to eliminate thermal bridges at window sills. Finish can be painted on site. Can be used on both new buildings and renovations.</p>	<p>Alféizar aislante en GFB (cemento reforzado en fibra de vidrio) laminado con EPS de alta densidad 30 kg/m<sup>3</sup>, perfecto para eliminar puentes térmicos en los vanos de las ventanas. El acabado admite recubrimiento de pintura en obra. Utilizable tanto en nuevas construcciones como en reacondicionamientos.</p>

## davanzali ALU

 scheda  
 tecnica

davanzale in alluminio	aluminium window sill	alféizar en aluminio
<p>Davanzale in lega di alluminio 20/10 (sp. 2 mm) utilizzabile sia su nuove costruzioni che ristrutturazioni. Su richiesta verniciatura in produzione (solo tinte RAL).</p>	<p>Window sill made of 20/10 aluminium alloy (th. 2 mm) Can be used on both new buildings and renovations. Upon request, can be painted in production (only RAL colours).</p>	<p>Alféizar en aleación de aluminio 20/10 (esp. 2 mm) utilizable tanto en nuevas construcciones como en reacondicionamientos. Bajo pedido, pintado de fábrica (solo tintes RAL).</p>



## armatex C1

 scheda  
tecnica

 data  
sheet

 ficha  
técnica

rete di armatura 160 gr/m <sup>2</sup>	reinforcement mesh - 160 g/m <sup>2</sup>	malla de armadura 160 gr/m <sup>2</sup>
<p>Rete di armatura in fibra di vetro apprettata, antidemagliante, resistente agli alcali, per sistemi di isolamento termico e in generale idonea per rasature armate con rasanti-colanti della gamma IVAS. Certificata come componente integrante del sistema di isolamento termico a cappotto. Dotato di omologazione secondo EAD 00416-00-0404</p>	<p>Sized, unravel-proof, glass fibre reinforcement mesh, resistant to alkalis, designed for thermal insulation systems and, in general, suitable for reinforced skimming with the IVAS line of adhesive-skim coats. Certified as an integral component of the external thermal insulation system. Certified according to EAD 00416-00-0404</p>	<p>Malla de armadura en fibra de vidrio apretada, antidesmallante, resistente a los álcalis, para sistemas de aislamiento térmico y en general idónea para enrasados armados con morteros de enrasado-colas de la gama IVAS. Certificada como componente integrante del sistema de aislamiento térmico por capas. Homologado según EAD 00416-00-0404</p>
<p><b>Colore:</b> grigia con scala graduata per il montaggio. <b>Categoria all'urto:</b> I e II <b>Resistenza all'urto:</b> 3 Joule e fino a 10 Joule con EPS MAX <b>Misure:</b> 1,10 x 50 m per totali 55 m<sup>2</sup> <b>Peso:</b> 160 g/m<sup>2</sup> <b>Resa</b> (con le necessarie sovrapposizioni): 1,10 m<sup>2</sup> di rete per 1 m<sup>2</sup> di supporto</p>	<p><b>Colours available:</b> grey with linear graduation for installation. <b>Impact category</b> I and II <b>Impact resistance:</b> 3 Joules and up to 10 Joules with EPS MAX <b>Size:</b> 1.10 x 50 m for a total of 55 m<sup>2</sup> <b>Weight:</b> 160 g/m<sup>2</sup> <b>Coverage</b> (with required overlapping): 1.10 m<sup>2</sup> of mesh per 1 m<sup>2</sup> of substrate</p>	<p><b>Gama de colores:</b> gris con escala graduada para el montaje. <b>Categoría de impacto:</b> I y II <b>Resistencia al impacto:</b> 3 julios y hasta 10 julios con EPS MÁX <b>Medidas:</b> 1,10 x 50 m por un total de 55 m<sup>2</sup> <b>Peso:</b> 160 g/m<sup>2</sup> <b>Rendimiento</b> (con las necesarias superposiciones): 1,10 m<sup>2</sup> de malla por 1 m<sup>2</sup> de soporte</p>

tecniche	certificazioni	proprietà	tecnologie

## armatex C1R

 scheda  
tecnica

 data  
sheet

 ficha  
técnica

rete di armatura 380 gr/m <sup>2</sup>	reinforcement mesh - 380 g/m <sup>2</sup>	malla de armadura 380 gr/m <sup>2</sup>
<p>Rete di armatura in fibra di vetro apprettata, antidemagliante, resistente agli alcali, apposta per migliorare la resistenza meccanica agli urti sui sistemi di isolamento a cappotto in particolare modo nella zona della zoccolatura. Certificata come componente integrante del sistema di isolamento termico a cappotto. Dotato di omologazione secondo EAD 00416-00-0404</p>	<p>Sized, unravel-proof, glass fibre reinforcement mesh, resistant to alkalis, designed to improve mechanical impact resistance on external thermal insulation systems, particularly in the area of building plinths. Certified as an integral component of the external thermal insulation system. Certified according to EAD 00416-00-0404</p>	<p>Malla de armadura en fibra de vidrio apretada, antidesmallante, resistente a los álcalis, idónea para mejorar la resistencia mecánica a los golpes en los sistemas de aislamiento por capas y en particular en la zona de rodapié. Certificada como componente integrante del sistema de aislamiento térmico por capas. Homologado según EAD 00416-00-0404</p>
<p><b>Colore:</b> gialla <b>Categoria all'urto:</b> I <b>Resistenza all'urto:</b> 10 Joule <b>Misure:</b> 1 x 25 m per totali 25 m<sup>2</sup> <b>Peso:</b> 380 g/m<sup>2</sup> <b>Resa</b> (con le necessarie sovrapposizioni): 1,10 m<sup>2</sup> di rete per 1 m<sup>2</sup> di supporto</p>	<p><b>Color:</b> yellow <b>Impact category</b> I <b>Impact resistance:</b> 10 Joule <b>Size:</b> 1 x 25 m for a total of 25 m<sup>2</sup> <b>Weight:</b> 380 g/m<sup>2</sup> <b>Coverage:</b> (with required overlapping) 1.10 m<sup>2</sup> of mesh per 1 m<sup>2</sup> of substrate</p>	<p><b>Color:</b> amarilla <b>Categoría de impacto:</b> I <b>Resistencia al impacto:</b> 10 julios <b>Medidas:</b> 1 x 25 m por un total de 25 m<sup>2</sup> <b>Peso:</b> 380 g/m<sup>2</sup> <b>Rendimiento:</b> (con los solapamientos necesarios) 1,10 m<sup>2</sup> de malla por 1 m<sup>2</sup> de soporte</p>

tecniche	certificazioni	proprietà	tecnologie

## armatex C1 M



scheda  
tecnica



data  
sheet



ficha  
técnica



rete di armatura 225 gr/m <sup>2</sup>	reinforcement mesh - 225 g/m <sup>2</sup>	malla de armadura 225 gr/m <sup>2</sup>
<p>Rete di armatura in fibra di vetro apprettata, antidemagliante, resistente agli alcali, per sistemi di isolamento Termok8 Modulari. Dotato di omologazione secondo EAD 00416-00-0404</p> <p>Necessaria per Termok8 Modulare e consigliata per Termok8 texture design</p>	<p>Sized, unravel-proof, glass fibre reinforcement mesh, resistant to alkalis, designed for the Termok8 modular insulation systems. Certified according to EAD 00416-00-0404</p> <p>Required for the Termok8: Modular system and recommended for the Termok8 texture design</p>	<p>Malla de armadura en fibra y vidrio aprestada, antidesmallante, resistente a los álcalis para sistemas de aislamiento Termok8 Modulares. Homologado según EAD 00416-00-0404</p> <p>Necesaria para Termok8 Modular y aconsejada para Termok8 texture design</p>
<p><b>Colore:</b> grigia con scala graduata per il montaggio.</p> <p><b>Resistenza all'urto:</b> 20Joule con EPS MAX e 60 Joule con Klebocem R110J</p> <p><b>Misure:</b> 1 x 50 m per totali 50 m<sup>2</sup></p> <p><b>Peso:</b> 225 g/m<sup>2</sup></p> <p><b>Resa</b> (con le necessarie sovrapposizioni): 1,10 m<sup>2</sup> di rete per 1 m<sup>2</sup> di supporto</p>	<p><b>Colours available:</b> grey with linear graduation for installation.</p> <p><b>Impact resistance:</b> 20 Joule with EPS MAX and 60 Joule with Klebocem R110J</p> <p><b>Size:</b> 1 x 50 m for a total of 50 m<sup>2</sup></p> <p><b>Weight:</b> 225 g/m<sup>2</sup></p> <p><b>Coverage</b> (with required overlapping): 1.10 m<sup>2</sup> of mesh per 1 m<sup>2</sup> of substrate</p>	<p><b>Colores:</b> gris con escala graduada para el montaje.</p> <p><b>Resistencia al impacto:</b> 20 julios con EPS MÁX y 60 julios con Klebocem R110J</p> <p><b>Medidas:</b> 1 x 50 m por un total de 50 m<sup>2</sup></p> <p><b>Peso:</b> 225 g/m<sup>2</sup></p> <p><b>Rendimiento</b> (con las necesarias superposiciones): 1,10 m<sup>2</sup> de malla por 1 m<sup>2</sup> de soporte</p>

tecniche	certificazioni	proprietà	tecnologie

## rete angolare per intradossi aperture



angolare preformato per imbotti aperture con armatura diagonale	shaped corner mesh for diagonally reinforced window and door intradoses	angular preformato para intradoses de aberturas con armadura diagonal
<p>Angolare preformato tridimensionale utilizzato per il rinforzo diagonale e degli angoli interni di imbotti di porte e finestre per sistemi di isolamento a cappotto. Prepiegato e presaldato.</p> <p>Realizzato con rete di armatura in fibra di vetro di tipo E, impregnata con resine antialcaline SBR, interasse 3,5 x 3,8 mm</p>	<p>Three-dimensionally shaped corner mesh used for diagonal and internal corner reinforcement of window and door intradoses for external thermal insulation systems. Pre-folded and pre-welded.</p> <p>Made of type E glass fibre reinforcement mesh, impregnated with SBR anti-alkaline resin, spacing 3.5 x 3.8 mm</p>	<p>Angular preformato tridimensional utilizado para el refuerzo diagonal y de los ángulos interiores de intradoses de puertas y ventanas para sistemas de aislamiento por capas. Predoblado y presoldado. Realizada con malla de armadura en fibra de vidrio de tipo E, impregnada con resinas antialcalinas SBR, distancia entre centros 3,5 x 3,8 mm</p>
<p><b>Peso:</b> 165 gr/m<sup>2</sup></p> <p><b>Misure:</b> 20 x 30 cm altezza 10 cm 20 x 30 cm altezza 20 cm</p> <p><b>Confezione:</b> 25 pezzi</p>	<p><b>Weight:</b> 165 gr/m<sup>2</sup></p> <p><b>Size:</b> 20 x 30 cm height 10 cm 20 x 30 cm height 20 cm</p> <p><b>Package:</b> 25 pieces</p>	<p><b>Peso:</b> 165 gr/m<sup>2</sup></p> <p><b>Medidas:</b> 20 x 30 cm altura 10 cm 20 x 30 cm altura 20 cm</p> <p><b>Envase:</b> 25 piezas</p>

## rete a fazzoletto per armatura spigoli finestre



rete di armatura per angoli aperture con armatura diagonale	reinforcement mesh for corner openings with diagonal reinforcement	malla de armadura para ángulos de aberturas con armadura diagonal
<p>Angolare preformato utilizzato per l'esecuzione dell'armatura diagonale in corrispondenza degli angoli di aperture come finestre e porte. Utilizzata come rinforzo per dissipare le tensioni e prevenire così fenomeni fessurativi, garantendo la continuità dell'armatura del sistema cappotto.</p> <p>Realizzato con rete di armatura in fibra di vetro di tipo E, impregnata con resine antialcaline SBR, interasse 3,5 x 3,8 mm</p>	<p>Shaped corner used for diagonal reinforcement of the corners of such openings as windows and doors. Used as a reinforcement to dissipate tensions and prevent cracking, thus guaranteeing continuity in the reinforcement of external thermal insulation systems.</p> <p>Made of type E glass fibre reinforcement mesh, impregnated with SBR anti-alkaline resin, spacing 3.5 x 3.8 mm</p>	<p>Angular preformato utilizzato para la ejecución de la armadura diagonal coincidiendo con los ángulos de aberturas como ventanas y puertas. Utilizada como refuerzo para dispersar las tensiones y prevenir así fenómenos de fisuras, garantizando la continuidad de la armadura del sistema por capas. Realizada con malla de armadura en fibra de vidrio de tipo E, impregnada con resinas antialcalinas SBR, distancia entre centros 3,5 x 3,8 mm</p>
<p><b>Peso:</b> 165 gr/m<sup>2</sup></p> <p><b>Misure:</b> 33,5 x 50 cm</p> <p><b>Confezione:</b> 50 pz</p>	<p><b>Weight:</b> 165 gr/m<sup>2</sup></p> <p><b>Size:</b> 33.5 x 50 cm</p> <p><b>Package:</b> 50 pcs</p>	<p><b>Peso:</b> 165 gr/m<sup>2</sup></p> <p><b>Medidas:</b> 33,5 x 50 cm</p> <p><b>Envase:</b> 50 piezas</p>



## rivatone plus g15

scheda  
tecnicadata  
sheetficha  
técnicarivestimento acrilico a  
spessore 1,5 mm**esterno**acrylic coating - 1.5  
mm thick**outdoor**revestimiento acrílico  
de espesor 1,5 mm**exterior**

Rivestimento a base di resine vinil-acriliche in dispersione, additivi atti a facilitare l'applicazione e la filmazione, graniglie di marmo e sabbie quarzifere ad assorbimento controllato grana max 1,5mm. Forma un film resistente all'attacco di alghe, funghi e muffe certificato dal Fraunhofer-Institut für Bauphysik di Monaco. Prodotto verificato secondo le norme UNI EN 15824 e ETAG n. 004 per l'uso del marchio CE. Per uso professionale.

Coating based on acrylic resins in dispersion. Contains additives that facilitate application and formation of a film as well as marble granules and quartz sand with controlled absorption, max particle size 1.5 mm. Forms a film resistant to algae, fungi, mould and mildew certified by the Fraunhofer-Institut für Bauphysik of Munich. Product tested according to UNI EN 15824 and ETAG no. 004 for use of CE marking. For professional use.

Revestimiento a base de resinas vinilicas-acrilicas en dispersión, aditivos con la función de facilitar la aplicación y la formación de película, granallas de mármol y arenas cuarcíferas de absorción controlada de grano máx 1,5 mm. Forma una película resistente al ataque de algas, hongos y mohos. Certificado por el Fraunhofer-Institut für Bauphysik de Munich. Producto verificado según las normas UNI EN 15824 y ETAG n.º 004 para el uso de la marca CE. Para uso profesional.

**Granulometria:** 1,5 mm**Attrezzatura:** frattazzo metallico, frattazzo di plastica**Diluizione:** pronto uso**Resa** (1 mano): 3 kg/m<sup>2</sup> - Per confezione (25 kg): 8,3 m<sup>2</sup>**Particle Size:** 1,5 mm**Equipment:** metal trowel, plastic trowel**Dilution:** ready to use**Coverage** (1 coat): 3 kg/m<sup>2</sup> - Per pack (25 kg): 8,3 m<sup>2</sup>**Granulometría:** 1,5 mm**Herramientas:** llana metálica, llana de plástico**Dilución:** listo para usar**Rendimiento** (1 capa): 3 kg/m<sup>2</sup> - Por envase (25 kg): 8,3 m<sup>2</sup>

tecniche	certificazioni	proprietà	tecnologie

## rivatone plus g12

scheda  
tecnicadata  
sheetficha  
técnicarivestimento acrilico a  
spessore 1,2 mm**esterno**acrylic coating - 1.2  
mm thick**outdoor**revestimiento acrílico  
de espesor 1,2 mm**exterior**

Rivestimento a base di resine vinil-acriliche in dispersione, additivi atti a facilitare l'applicazione e la filmazione, graniglie di marmo e sabbie quarzifere ad assorbimento controllato grana max 1,2mm. Forma un film resistente all'attacco di alghe, funghi e muffe certificato dal Fraunhofer-Institut für Bauphysik di Monaco. Prodotto verificato secondo le norme UNI EN 15824 e ETAG n. 004 per l'uso del marchio CE. Per uso professionale.

Coating based on acrylic resins in dispersion. Contains additives that facilitate application and formation of a film as well as marble granules and quartz sand with controlled absorption, max particle size 1.2mm. Forms a film resistant to algae, fungi, mould and mildew certified by the Fraunhofer-Institut für Bauphysik of Munich. Product tested according to UNI EN 15824 and ETAG no. 004 for use of CE marking. For professional use.

Revestimiento a base de resinas vinilicas-acrilicas en dispersión, aditivos con la función de facilitar la aplicación y la formación de película, granallas de mármol y arenas cuarcíferas de absorción controlada de grano máx 1,2mm. Forma una película resistente al ataque de algas, hongos y mohos. Certificado por el Fraunhofer-Institut für Bauphysik de Munich. Producto verificado según las normas UNI EN 15824 y ETAG n.º 004 para el uso de la marca CE. Para uso profesional.

**Granulometria:** 1,2 mm**Attrezzatura:** frattazzo metallico, frattazzo di plastica**Diluizione:** pronto uso**Resa** (1 mano): 2,2 kg/m<sup>2</sup> - Per confezione (25 kg): 11,5 m<sup>2</sup>**Particle Size:** 1,2 mm**Equipment:** metal trowel, plastic trowel**Dilution:** ready to use**Coverage** (1 coat): 2,2 kg/m<sup>2</sup> - Per pack (25 kg): 11,5 m<sup>2</sup>**Granulometría:** 1,2 mm**Herramientas:** llana metálica, llana de plástico**Dilución:** listo para usar**Rendimiento** (1 capa): 2,2 kg/m<sup>2</sup> - Por envase (25 kg): 11,5 m<sup>2</sup>

tecniche	certificazioni	proprietà	tecnologie

## rivatone idrosiliconico plus g15



scheda  
tecnica



data  
sheet



ficha  
técnica



rivestimento metilsiliconico a spessore 1,5 mm	<b>esterno</b>	methylsilicone coating - 1.5 mm thick	<b>outdoor</b>	revestimiento metilsilicónico de 1,5 mm de espesor	<b>exterior</b>
Rivestimento fibrato ad effetto minerale compatto a base di resine metil silossaniche, graniglie di quarzo e marmo grana max 1,5mm, additivi atti a facilitare l'applicazione e la filmazione, ad assorbimento controllato. Ottima idrorepellenza e traspirabilità. Forma un film resistente all'attacco di alghe, funghi e muffe, certificato dal Fraunhofer-Institut für Bauphysik di Monaco. Per uso professionale.		Fibre-reinforced coating with compact mineral-effect based on methylsiloxane resins, quartz and marble granules (max. particle size 1.5 mm) plus additives to facilitate application and formation of a film, with controlled absorption. Superb breathability and water-repellent properties. Forms a film resistant to algae, fungi, mould and mildew certified by the Fraunhofer-Institut für Bauphysik of Munich. For professional use.		Revestimiento fibrado de efecto mineral compacto a base de resinas metilsiloxánicas, granallas de cuarzo y mármol, grano máx. 1,5 mm, aditivos para facilitar la aplicación y la formación de película, de absorción controlada. Excelente hidrorrepelencia y transpirabilidad. Forma una película resistente al ataque de algas, hongos y mohos, certificado por el Fraunhofer-Institut für Bauphysik de Munich. Para uso profesional.	
<b>Granulometria:</b> 1,5 mm <b>Attrezzatura:</b> frattazzo metallico, frattazzo di plastica <b>Diluizione:</b> pronto uso <b>Resa (1 mano):</b> 3 kg/m <sup>2</sup> - Per confezione (25 kg): 8,3 m <sup>2</sup>		<b>Particle Size:</b> 1,5 mm <b>Equipment:</b> metal trowel, plastic trowel <b>Dilution:</b> ready to use <b>Coverage</b> (1 coat): 3 kg/m <sup>2</sup> - Per pack (25 kg): 8.3 m <sup>2</sup>		<b>Granulometría:</b> 1,5 mm <b>Herramientas:</b> llana metálica, llana de plástico <b>Dilución:</b> listo para usar <b>Rendimiento</b> (1 capa): 3 kg/m <sup>2</sup> - Por envase (25 kg): 8,3 m <sup>2</sup>	

<b>tecniche</b>	<b>certificazioni</b>	<b>proprietà</b>	<b>tecnologie</b>

## rivatone idrosiliconico plus g12



scheda  
tecnica



data  
sheet



ficha  
técnica



rivestimento metilsiliconico a spessore 1,2 mm	<b>esterno</b>	methylsilicone coating - 1.2 mm thick	<b>outdoor</b>	revestimiento metilsilicónico de 1,2 mm de espesor	<b>exterior</b>
Rivestimento fibrato ad effetto minerale compatto a base di resine metil silossaniche, graniglie di quarzo e marmo grana max 1,2mm, additivi atti a facilitare l'applicazione e la filmazione, ad assorbimento controllato. Ottima idrorepellenza e traspirabilità. Forma un film resistente all'attacco di alghe, funghi e muffe, certificato dal Fraunhofer-Institut für Bauphysik di Monaco. Per uso professionale.		Fibre-reinforced coating with compact mineral-effect based on methylsiloxane resins, quartz and marble granules (max. Particle Size: 1.2mm) plus additives to facilitate application and formation of a film, with controlled absorption. Superb breathability and water-repellent properties. Forms a film resistant to algae, fungi, mould and mildew certified by the Fraunhofer-Institut für Bauphysik of Munich. For professional use.		Revestimiento fibrado de efecto mineral compacto a base de resinas metilsiloxánicas, granallas de cuarzo y mármol, grano máx. 1,2mm, aditivos para facilitar la aplicación y la formación de película, de absorción controlada. Excelente hidrorrepelencia y transpirabilidad. Forma una película resistente al ataque de algas, hongos y mohos, certificado por el Fraunhofer-Institut für Bauphysik de Munich. Para uso profesional.	
<b>Granulometria:</b> 1,2 mm <b>Attrezzatura:</b> frattazzo metallico, frattazzo di plastica <b>Diluizione:</b> pronto uso <b>Resa (1 mano):</b> 2,2 kg/m <sup>2</sup> - Per confezione (25 kg): 11,4 m <sup>2</sup>		<b>Particle Size:</b> 1,2 mm <b>Equipment:</b> metal trowel, plastic trowel <b>Dilution:</b> ready to use <b>Coverage</b> (1 coat): 2.2 kg/m <sup>2</sup> - Per pack (25 kg): 11.4 m <sup>2</sup>		<b>Granulometría:</b> 1,2 mm <b>Herramientas:</b> llana metálica, llana de plástico <b>Dilución:</b> listo para usar <b>Rendimiento</b> (1 capa): 2,2 kg/m <sup>2</sup> - Por envase (25 kg): 11,4 m <sup>2</sup>	

<b>tecniche</b>	<b>certificazioni</b>	<b>proprietà</b>	<b>tecnologie</b>

## rivatone plus trv g15

scheda  
tecnicadata  
sheetficha  
técnica

rivestimento acrilossilossanico a spessore 1,5 mm	esterno	acrylic-siloxane coating - 1.5 mm thick	outdoor	revestimiento acrilsiloxánico de espesor 1,5 mm	exterior
<p>Rivestimento fibrato ad effetto compatto a base di resine acriliche e silossani idrofobizzati grana max 1,5mm indicato come finitura per i principali sistemi Termok8. A film protetto dall'attacco di alghe, muffe e microorganismi. certificato dal Fraunhofer-Institut für Bauphysik di Monaco. Prodotto verificato secondo le norme UNI EN 15824 e ETAG n. 004 per l'uso del marchio CE. Per uso professionale.</p>		<p>Fibre-reinforced coating with compact effect based on acrylic resins and water-repellent siloxanes with a maximum particle size of 1.5 mm, suitable as top coat for the main Termok8 systems. Forms a film resistant to algae, mould and microorganisms certified by the Fraunhofer-Institut für Bauphysik of Munich. Product tested according to UNI EN 15824 and ETAG no. 004 for use of CE marking. For professional use.</p>		<p>Revestimiento fibrado de efecto compacto a base de resinas acrílicas y siloxanos hidrofobizados, grano máx. 1,5 mm indicado como acabado para los principales sistemas Termok8. Película protegida contra el ataque de algas, mohos y microorganismos. Certificado por el Fraunhofer-Institut für Bauphysik de Munich. Producto verificado según las normas UNI EN 15824 y ETAG n.º 004 para el uso de la marca CE. Para uso profesional.</p>	
<p><b>Granulometria:</b> 1,5 mm <b>Attrezzatura:</b> frattazzo metallico, frattazzo di plastica <b>Diluizione:</b> pronto uso <b>Resa</b> (1 mano): 3 kg/m<sup>2</sup> - Per confezione (25 kg): 8,3 m<sup>2</sup></p>		<p><b>Particle Size:</b> 1,5 mm <b>Equipment:</b> metal trowel, plastic trowel <b>Dilution:</b> ready to use <b>Coverage</b> (1 coat): 3 kg/m<sup>2</sup> - Per pack (25 kg): 8,3 m<sup>2</sup></p>		<p><b>Granulometría:</b> 1,5 mm <b>Herramientas:</b> llana metálica, llana de plástico <b>Dilución:</b> listo para usar <b>Rendimiento</b> (1 capa): 3 kg/m<sup>2</sup> - Por envase (25 kg): 8,3 m<sup>2</sup></p>	

tecniche	certificazioni	proprietà	tecnologie
COLOURABLE WATER BASED TROWEL READY TO USE	BBA ETA CE EN 15824 EPD BREATHABLE	V2 BREATHABLE	plus siloxan 4

## rivatone plus trv g12

scheda  
tecnicadata  
sheetficha  
técnica

rivestimento acrilossilossanico a spessore 1,2 mm	esterno	acrylic-siloxane coating - 1.2 mm thick	outdoor	revestimiento acrilsiloxánico de espesor 1,2 mm	exterior
<p>Rivestimento fibrato ad effetto compatto a base di resine acriliche e silossani idrofobizzati grana max 1,2mm indicato come finitura per i principali sistemi Termok8. A film protetto dall'attacco di alghe, muffe e microorganismi. certificato dal Fraunhofer-Institut für Bauphysik di Monaco. Prodotto verificato secondo le norme UNI EN 15824 e ETAG n. 004 per l'uso del marchio CE. Per uso professionale.</p>		<p>Fibre-reinforced coating with compact effect based on acrylic resins and water-repellent siloxanes with a maximum particle size of 1.2mm, suitable as top coat for the main Termok8 systems. Forms a film resistant to algae, mould and microorganisms certified by the Fraunhofer-Institut für Bauphysik of Munich. Product tested according to UNI EN 15824 and ETAG no. 004 for use of CE marking. For professional use.</p>		<p>Revestimiento fibrado de efecto compacto a base de resinas acrílicas y siloxanos hidrofobizados, grano máx. 1,2mm indicado como acabado para los principales sistemas Termok8. Película protegida contra el ataque de algas, mohos y microorganismos. Certificado por el Fraunhofer-Institut für Bauphysik de Munich. Producto verificado según las normas UNI EN 15824 y ETAG n.º 004 para el uso de la marca CE. Para uso profesional.</p>	
<p><b>Granulometria:</b> 1,2 mm <b>Attrezzatura:</b> frattazzo metallico, frattazzo di plastica <b>Diluizione:</b> pronto uso <b>Resa</b> (1 mano): 2,2 kg/m<sup>2</sup> - Per confezione (25 kg): 12 m<sup>2</sup></p>		<p><b>Particle Size:</b> 1,2 mm <b>Equipment:</b> metal trowel, plastic trowel <b>Dilution:</b> ready to use <b>Coverage</b> (1 coat): 2,2 kg/m<sup>2</sup> - Per pack (25 kg): 12 m<sup>2</sup></p>		<p><b>Granulometría:</b> 1,2 mm <b>Herramientas:</b> llana metálica, llana de plástico <b>Dilución:</b> listo para usar <b>Rendimiento</b> (1 capa): 2,2 kg/m<sup>2</sup> - Por envase (25 kg): 12 m<sup>2</sup></p>	

tecniche	certificazioni	proprietà	tecnologie
COLOURABLE WATER BASED TROWEL READY TO USE	BBA ETA CE EN 15824 EPD BREATHABLE	V2 BREATHABLE	plus siloxan 4

# rivatone plus trv g10



scheda  
tecnica



data  
sheet



ficha  
técnica



rivestimento acrilossilossanico a spessore 1,0 mm	<b>esterno</b>	acrylic-siloxane coating - 1.0 mm thick	<b>outdoor</b>	revestimiento acrilossiloxánico de espesor 1,0 mm	<b>exterior</b>
Rivestimento fibrato ad effetto compatto a base di resine acriliche e silossani idrofobizzati grana max 1mm indicato come finitura per i principali sistemi Termok8. A film protetto dall'attacco di alghe, muffe e microorganismi. certificato dal Fraunhofer-Institut für Bauphysik di Monaco. Prodotto verificato secondo le norme UNI EN 15824 e ETAG n. 004 per l'uso del marchio CE. Per uso professionale.		Fibre-reinforced coating with compact effect based on acrylic resins and water-repellent siloxanes with a maximum particle size of 1mm, suitable as top coat for the main Termok8 systems. Forms a film resistant to algae, mould and microorganisms certified by the Fraunhofer-Institut für Bauphysik of Munich. Product tested according to UNI EN 15824 and ETAG no. 004 for use of CE marking. For professional use.		Revestimiento fibrado de efecto compacto a base de resinas acrílicas y siloxanos hidrofobizados, grano máx. 1mm indicado como acabado para los principales sistemas Termok8. Película protegida contra el ataque de algas, mohos y microorganismos. Certificado por el Fraunhofer-Institut für Bauphysik de Munich. Producto verificado según las normas UNI EN 15824 y ETAG n.º 004 para el uso de la marca CE. Para uso profesional.	
<b>Granulometria:</b> 1,0 mm <b>Attrezzatura:</b> frattazzo metallico, frattazzo di plastica <b>Diluizione:</b> pronto uso <b>Resa (1 mano):</b> 1,8 kg/m <sup>2</sup> - Per confezione (25 kg): 13,9 m <sup>2</sup>		<b>Particle Size:</b> 1,0 mm <b>Equipment:</b> metal trowel, plastic trowel <b>Dilution:</b> ready to use <b>Coverage</b> (1 coat): 1,8 kg/m <sup>2</sup> - Per pack (25 kg): 13,9 m <sup>2</sup>		<b>Granulometría:</b> 1,0 mm <b>Herramientas:</b> llana metálica, llana de plástico <b>Dilución:</b> listo para usar <b>Rendimiento</b> (1 capa): 1,8 kg/m <sup>2</sup> - Por envase (25 kg): 13,9 m <sup>2</sup>	

tecniche				certificazioni				proprietà				tecnologie			

## rivatone plus reflect g15

scheda  
tecnicadata  
sheetficha  
técnica

rivestimento a spessore riflettente a grana 1,5mm	esterno	thick reflective coating - particle size 1.5 mm	outdoor	revestimiento de espesor reflectante de grano 1,5 mm	exterior
La sua formulazione a base di resine acriliche e graniglie max 1,5mm prevede l'uso di pigmenti "freddi" idonei a riflettere la luce nello spettro IR. Permette di realizzare finiture scure, anche nere, su cappotto termico limitando il riscaldamento eccessivo della superficie. Prodotto verificato secondo le norme UNI EN 15824 per l'uso del marchio CE. Per uso professionale.		Its formulation based on acrylic resins and granules of max 1.5 mm involves the use of "cold" pigments able to reflect the light in the IR spectrum. Makes it possible to create dark, even black, topcoats on thermal insulation systems, limiting excessive heating of the surface. Product tested according to UNI EN 15824 for use of CE marking. For professional use.		Su formulación a base de resinas acrílicas y granallas máx. 1,5 mm incluye pigmentos "fríos" idóneos para reflejar la luz de espectro IR. Permite realizar acabados oscuros, incluso negros, sobre sistema por capas térmico limitando el calentamiento excesivo de la superficie. Producto verificado según las normas UNI EN 15824 para el uso de la marca CE. Para uso profesional.	
<b>Granulometria:</b> 1,5 mm <b>Attrezzatura:</b> frattazzo metallico, frattazzo di plastica <b>Diluizione:</b> pronto uso <b>Resa</b> (1 mano): 3 kg/m <sup>2</sup> - Per confezione (25 kg): 8,3 m <sup>2</sup>		<b>Particle Size:</b> 1,5 mm <b>Equipment:</b> metal trowel, plastic trowel <b>Dilution:</b> ready to use <b>Coverage</b> (1 coat): 3 kg/m <sup>2</sup> - Per pack (25 kg): 8.3 m <sup>2</sup>		<b>Granulometría:</b> 1,5 mm <b>Herramientas:</b> llana metálica, llana de plástico <b>Dilución:</b> listo para usar <b>Rendimiento</b> (1 capa): 3 kg/m <sup>2</sup> - Por envase (25 kg): 8,3 m <sup>2</sup>	

tecniche	certificazioni	proprietà	tecnologie
WATER BASED TROWEL READY TO USE	BBA CE ETA BREATHABLE		reflect plus

## rivatone plus reflect g12

scheda  
tecnicadata  
sheetficha  
técnica

rivestimento a spessore riflettente a grana 1,2mm	esterno	thick reflective coating - particle size 1.2mm	outdoor	revestimiento de espesor reflectante de grano 1,2mm	exterior
La sua formulazione a base di resine acriliche e graniglie max 1,2mm prevede l'uso di pigmenti "freddi" idonei a riflettere la luce nello spettro IR. Permette di realizzare finiture scure, anche nere, su cappotto termico limitando il riscaldamento eccessivo della superficie. Prodotto verificato secondo le norme UNI EN 15824 per l'uso del marchio CE. Per uso professionale.		Its formulation based on acrylic resins and granules of max 1.2mm involves the use of "cold" pigments able to reflect the light in the IR spectrum. Makes it possible to create dark, even black, topcoats on thermal insulation systems, limiting excessive heating of the surface. Product tested according to UNI EN 15824 for use of CE marking. For professional use.		Su formulación a base de resinas acrílicas y granallas máx. 1,2mm incluye pigmentos "fríos" idóneos para reflejar la luz de espectro IR. Permite realizar acabados oscuros, incluso negros, sobre sistema por capas térmico limitando el calentamiento excesivo de la superficie. Producto verificado según las normas UNI EN 15824 para el uso de la marca CE. Para uso profesional.	
<b>Granulometria:</b> 1,2 mm <b>Attrezzatura:</b> frattazzo metallico, frattazzo di plastica <b>Diluizione:</b> pronto uso <b>Resa</b> (1 mano): 2,2 kg/m <sup>2</sup> - Per confezione (25 kg): 11,4 m <sup>2</sup>		<b>Particle Size:</b> 1,2 mm <b>Equipment:</b> metal trowel, plastic trowel <b>Dilution:</b> ready to use <b>Coverage</b> (1 coat): 2.2 kg/m <sup>2</sup> - Per pack (25 kg): 11.4 m <sup>2</sup>		<b>Granulometría:</b> 1,2 mm <b>Herramientas:</b> llana metálica, llana de plástico <b>Dilución:</b> listo para usar <b>Rendimiento</b> (1 capa): 2,2 kg/m <sup>2</sup> - Por envase (25 kg): 11,4 m <sup>2</sup>	

tecniche	certificazioni	proprietà	tecnologie
WATER BASED TROWEL READY TO USE	BBA CE ETA BREATHABLE		reflect plus



## rivatone plus strong g15



scheda  
tecnica



data  
sheet



ficha  
técnica



rivestimento per tinte intense a grana 1,5mm <b>esterno</b>	coating for intense colours - particle size 1.5mm <b>outdoor</b>	revestimiento para tintes intensos de grano 1,5 mm <b>exterior</b>
A base di resine acriliche in dispersione, additivi atti a facilitare l'applicazione e la fil-mazione, battericidi e fungicidi a vasto spet-tro d'azione, graniglie di marmo e sabbie quarzifere ad assorbimento controllato max 1,5mm. Permette di ottenere una vasta gam-ma di colori intensi e dal tono estremamente vivo minimizzando i rischi di decolorazione nel tempo. Prodotto verificato secondo le norme UNI EN 15824 per l'uso del marchio CE. Per uso professionale.	Based on acrylic resins in dispersion, contains additives to facilitate application and formation of a film. Contains broad spectrum bactericides, fungicides, marble granules and quartz sand with controlled absorption, max particle size 1.5 mm. Makes it possible to obtain a wide range of in-tense colours with vibrant tone, minimising the risk of discolouration over time. Product tested according to UNI EN 15824 for use of CE marking. For professional use.	A base de resinas acrílicas en dispersión, aditivos con la función de facilitar la aplica-ción y la formación de película, bactericidas y fungicidas de amplio espectro de acción, granallas de mármol y arenas cuarcíferas de absorción controlada máx 1,5 mm. Per-mite obtener una amplia gama de colores intensos y de tono extremadamente vivo, minimizando los riesgos de decoloración en el tiempo. Producto verificado según las normas UNI EN 15824 para el uso de la marca CE. Para uso profesional.
<b>Granulometria:</b> 1,5 mm <b>Attrezzatura:</b> frattazzo metallico, frattazzo di plastica <b>Diluizione:</b> pronto uso <b>Resa (1 mano):</b> 3 kg/m <sup>2</sup> - Per confezione (25 kg): 8,3 m <sup>2</sup>	<b>Particle Size:</b> 1,5 mm <b>Equipment:</b> metal trowel, plastic trowel <b>Dilution:</b> ready to use <b>Coverage</b> (1 coat): 3 kg/m <sup>2</sup> - Per pack (25 kg): 8,3 m <sup>2</sup>	<b>Granulometría:</b> 1,5 mm <b>Herramientas:</b> llana metálica, llana de plástico <b>Dilución:</b> listo para usar <b>Rendimiento</b> (1 capa): 3 kg/m <sup>2</sup> - Por envase (25 kg): 8,3 m <sup>2</sup>

<b>tecniche</b> 	<b>certificazioni</b> 	<b>proprietà</b>	<b>tecnologie</b> 
---------------------	---------------------------	------------------	-----------------------

## rivatone plus strong g12



scheda  
tecnica



data  
sheet



ficha  
técnica



rivestimento per tinte intense a grana 1,2mm <b>esterno</b>	coating for intense colours - particle size 1.2mm <b>outdoor</b>	revestimiento para tintes intensos de grano 1,2mm <b>exterior</b>
A base di resine acriliche in dispersione, additivi atti a facilitare l'applicazione e la fil-mazione, battericidi e fungicidi a vasto spet-tro d'azione, graniglie di marmo e sabbie quarzifere ad assorbimento controllato max 1,2mm. Permette di ottenere una vasta gam-ma di colori intensi e dal tono estremamente vivo minimizzando i rischi di decolorazione nel tempo. Prodotto verificato secondo le norme UNI EN 15824 per l'uso del marchio CE. Per uso professionale.	Based on acrylic resins in dispersion, contains additives to facilitate application and formation of a film. Contains broad spectrum bactericides, fungicides, marble granules and quartz sand with controlled absorption, max particle size 1.2mm. Makes it possible to obtain a wide range of intense colours with vibrant tone, minimising the risk of discolouration over time. Product tested according to UNI EN 15824 for use of CE marking. For professional use.	A base de resinas acrílicas en dispersión, aditivos con la función de facilitar la aplica-ción y la formación de película, bactericidas y fungicidas de amplio espectro de acción, granallas de mármol y arenas cuarcíferas de absorción controlada máx 1,2mm. Per-mite obtener una amplia gama de colores intensos y de tono extremadamente vivo, minimizando los riesgos de decoloración en el tiempo. Producto verificado según las normas UNI EN 15824 para el uso de la marca CE. Para uso profesional.
<b>Granulometria:</b> 1,2 mm <b>Attrezzatura:</b> frattazzo metallico, frattazzo di plastica <b>Diluizione:</b> pronto uso <b>Resa (1 mano):</b> 2,2 kg/m <sup>2</sup> - Per confezione (25 kg): 11,4 m <sup>2</sup>	<b>Particle Size:</b> 1,2 mm <b>Equipment:</b> metal trowel, plastic trowel <b>Dilution:</b> ready to use <b>Coverage</b> (1 coat): 2,2 kg/m <sup>2</sup> - Per pack (25 kg): 11,4 m <sup>2</sup>	<b>Granulometría:</b> 1,2 mm <b>Herramientas:</b> llana metálica, llana de plástico <b>Dilución:</b> listo para usar <b>Rendimiento</b> (1 capa): 2,2 kg/m <sup>2</sup> - Por en-vase (25 kg): 11,4 m <sup>2</sup>

<b>tecniche</b> 	<b>certificazioni</b> 	<b>proprietà</b>	<b>tecnologie</b> 
---------------------	---------------------------	------------------	-----------------------

## rivatone clean plus g15

scheda  
tecnicadata  
sheetficha  
técnica

rivestimento acrilsilossanico autopulente 1,5 mm	esterno	self-cleaning acrylic- siloxane coating - 1.5 mm	outdoor	revestimiento acrilsiloxánico autolimpiador 1,5 mm	exterior
Rivestimento granulometria max 1,5mm estremamente bianco che unisce alla caratteristica di traspirabilità, conferita dalla componente silossanica, un effetto fotocatalitico ossidante in grado di decomporre le sostanze organiche che vengono a contatto con la superficie, il supporto rimarrà, di conseguenza, bianco come appena realizzato. Resistente all'attacco di alghe, funghi e muffe certificato dal Fraunhofer-Institut für Bauphysik di Monaco. Per uso professionale.		Extremely white coating (max. particle size: 1.5 mm) that combines the breathability characteristic of the siloxane component with an oxidative photocatalytic effect capable of decomposing the organic substances that come into contact with the surface, thus ensuring that the substrate will remain as white as when first applied. Resistance to algae, fungi, mould and mildew certified by the Fraunhofer-Institut für Bauphysik of Munich. For professional use.		Revestimiento con granulometría máx.1,5 mm extremadamente blanco que une a la característica de traspirabilidad, proporcionada por el componente siloxánico, un efecto foto-catalítico oxidante capaz de descomponer las sustancias orgánicas que entran en contacto con la superficie; el soporte quedará, por consiguiente, blanco como recién hecho. Resistente al ataque de algas, hongos y mohos. Certificado por el Fraunhofer-Institut für Bauphysik de Munich. Para uso profesional.	
<b>Granulometria:</b> 1,5 mm <b>Attrezzatura:</b> frattazzo metallico, frattazzo di plastica <b>Diluizione:</b> pronto uso <b>Resa</b> (1 mano): 3 kg/m <sup>2</sup> - Per confezione (25 kg): 8,3 m <sup>2</sup>		<b>Particle Size:</b> 1,5 mm <b>Equipment:</b> metal trowel, plastic trowel <b>Dilution:</b> ready to use <b>Coverage</b> (1 coat): 3 kg/m <sup>2</sup> - Per pack (25 kg): 8.3 m <sup>2</sup>		<b>Granulometría:</b> 1,5 mm <b>Herramientas:</b> llana metálica, llana de plástico <b>Dilución:</b> listo para usar <b>Rendimiento</b> (1 capa): 3 kg/m <sup>2</sup> - Por envase (25 kg): 8,3 m <sup>2</sup>	

## tecniche



## certificazioni



## proprietà

## tecnologie



## rivatone clean plus g12

scheda  
tecnicadata  
sheetficha  
técnica

rivestimento acrilsilossanico autopulente 1,2 mm	esterno	self-cleaning acrylic- siloxane coating - 1.2 mm	outdoor	revestimiento acrilsiloxánico autolimpiador 1,2 mm	exterior
Rivestimento granulometria max 1,2mm estremamente bianco che unisce alla caratteristica di traspirabilità, conferita dalla componente silossanica, un effetto fotocatalitico ossidante in grado di decomporre le sostanze organiche che vengono a contatto con la superficie, il supporto rimarrà, di conseguenza, bianco come appena realizzato. Resistente all'attacco di alghe, funghi e muffe certificato dal Fraunhofer-Institut für Bauphysik di Monaco. Per uso professionale.		Extremely white coating (max. particle size: 1.2mm) that combines the breathability characteristic of the siloxane component with an oxidative photocatalytic effect capable of decomposing the organic substances that come into contact with the surface, thus ensuring that the substrate will remain as white as when first applied. Resistance to algae, fungi, mould and mildew certified by the Fraunhofer-Institut für Bauphysik of Munich. For professional use.		Revestimiento con granulometría máx 1,2 m extremadamente blanco que une a la característica de traspirabilidad, proporcionada por el componente siloxánico, un efecto foto-catalítico oxidante capaz de descomponer las sustancias orgánicas que entran en contacto con la superficie; el soporte quedará, por consiguiente, blanco como recién hecho. Resistente al ataque de algas, hongos y mohos. Certificado por el Fraunhofer-Institut für Bauphysik de Munich. Para uso profesional.	
<b>Granulometria:</b> 1,2 mm <b>Attrezzatura:</b> frattazzo metallico, frattazzo di plastica <b>Diluizione:</b> pronto uso <b>Resa</b> (1 mano): 2,2 kg/m <sup>2</sup> - Per confezione (25 kg): 12,5 m <sup>2</sup>		<b>Particle Size:</b> 1,2 mm <b>Equipment:</b> metal trowel, plastic trowel <b>Dilution:</b> ready to use <b>Coverage</b> (1 coat): 2,2 kg/m <sup>2</sup> - Per pack (25 kg): 12.5 m <sup>2</sup>		<b>Granulometría:</b> 1,2 mm <b>Herramientas:</b> llana metálica, llana de plástico <b>Dilución:</b> listo para usar <b>Rendimiento</b> (1 capa): 2,2 kg/m <sup>2</sup> - Por envase (25 kg): 12,5 m <sup>2</sup>	

## tecniche



## certificazioni



## proprietà

## tecnologie



## rivatone clean plus g10



scheda  
tecnica



data  
sheet



ficha  
técnica



rivestimento acrilossilossanico autopulente 1,0 mm	<b>esterno</b>	self-cleaning acrylic- siloxane coating - 1.0 mm	<b>outdoor</b>	revestimiento acrilossiloxánico autolimpiador 1,0 mm	<b>exterior</b>
Rivestimento granulometria max 1mm estremamente bianco che unisce alla caratteristica di traspirabilità, conferita dalla componente silossanica, un effetto fotocatalitico ossidante in grado di decomporre le sostanze organiche che vengono a contatto con la superficie, il supporto rimarrà, di conseguenza, bianco come appena realizzato. Resistente all'attacco di alghe, funghi e muffe certificato dal Fraunhofer-Institut für Bauphysik di Monaco. Per uso professionale.		Extremely white coating (max.particle size 1mm) that combines the breathability characteristic of the siloxane component with an oxidative photocatalytic effect capable of decomposing the organic substances that come into contact with the surface, thus ensuring that the substrate will remain as white as when first applied. Resistance to algae, fungi, mould and mildew certified by the Fraunhofer-Institut für Bauphysik of Munich. For professional use.		Revestimiento con granulometría máx 1mm extremadamente blanco que une a la característica de traspirabilidad, proporcionada por el componente siloxánico, un efecto foto-catalítico oxidante capaz de descomponer las sustancias orgánicas que entran en contacto con la superficie; el soporte quedará, por consiguiente, blanco como recién hecho. Resistente al ataque de algas, hongos y mohos. Certificado por el Fraunhofer-Institut für Bauphysik de Munich. Para uso profesional.	
<b>Granulometria:</b> 1,0 mm <b>Attrezzatura:</b> frattazzo metallico, frattazzo di plastica <b>Diluizione:</b> pronto uso <b>Resa (1 mano):</b> 1,8 kg/m <sup>2</sup> - Per confezione (25 kg): 13,9 m <sup>2</sup>		<b>Particle Size:</b> 1,0 mm <b>Equipment:</b> metal trowel, plastic trowel <b>Dilution:</b> ready to use <b>Coverage (1 coat):</b> 1,8 kg/m <sup>2</sup> - Per pack (25 kg): 13.9 m <sup>2</sup>		<b>Granulometría:</b> 1,0 mm <b>Herramientas:</b> llana metálica, llana de plástico <b>Dilución:</b> listo para usar <b>Rendimiento (1 capa):</b> 1,8 kg/m <sup>2</sup> - Por envase (25 kg): 13,9 m <sup>2</sup>	

<b>tecniche</b>	<b>certificazioni</b>	<b>proprietà</b>	<b>tecnologie</b>

## fondo K plus



scheda  
tecnica



data  
sheet



fondo acrilossilossanico all'acqua pigmentato	<b>esterno</b>	water-based pigmented acrylic- siloxane base coat	<b>outdoor</b>	fondo acrilossiloxánico al agua pigmentado	<b>exterior</b>
Fondo intermedio coprente per rivestimento a cappotto specifico per successiva applicazione di rivestimenti colorati a spessore. La tecnologia PLUS garantisce la protezione del film dall'attacco di alghe, muffe e microorganismi. La Classe TVOC A+ lo rende idoneo per ottemperare ai protocolli CAM, -Leed Breeam. Per uso professionale.		Opaque intermediate base coat for external thermal insulation system specifically designed for subsequent application of thick coloured coatings. The PLUS technology ensures that the film is resistant to algae, mould and microorganisms. Classified TVOC A+, it complies with CAM, Leed Breeam protocols. For professional use.		Fondo intermedio cubriente para revestimiento por capas específico para la posterior aplicación de revestimientos de color en espesor. La tecnología PLUS garantiza la protección de la película contra el ataque de algas, mohos y microorganismos. La Clase TVOC A+ la hace idónea para cumplir con los protocolos CAM, Leed y Breeam. Para uso profesional.	
<b>Attrezzatura:</b> pennello, rullo a pelo corto, airless <b>Diluizione:</b> acqua - 10-20% <b>Resa (1 mano):</b> 4-4,5 m <sup>2</sup> /l - Per confezione (14 l): 63 m <sup>2</sup>		<b>Equipment:</b> brush, short-haired roller, airless spraying equipment <b>Dilution:</b> water - 10-20% <b>Coverage (1 coat):</b> 4-4.5 m <sup>2</sup> /l - Per pack (14 l): 63 m <sup>2</sup>		<b>Herramientas:</b> brocha, rodillo de pelo corto, pistola pulverizadora <b>Dilución:</b> agua - 10-20 % <b>Rendimiento (1 capa):</b> 4-4,5 m <sup>2</sup> /l- Por envase (14 l): 63 m <sup>2</sup>	

<b>tecniche</b>	<b>certificazioni</b>	<b>proprietà</b>	<b>tecnologie</b>

## listellotto buchtal

 scheda  
tecnica

 data  
sheet

 ficha  
técnica

listello in gres porcellanato estruso	strip in extruded porcelain stoneware	listón de gres porcelánico extrusionado
Linea Base Gold Line in grès	Gold Line basic line, stoneware	Línea Base Gold Line en gres
<b>Per sistema Termok8:</b> Modular D <b>Dimensioni:</b> 25 x 8,30 cm <b>Confezione:</b> 1 scatola = m <sup>2</sup> 0,83	<b>For system Termok8:</b> Modular D <b>Size:</b> 25 x 8.30 cm <b>Package:</b> 1 box = 0.83 m <sup>2</sup>	<b>Para sistema Termok8:</b> Modular D <b>Medidas:</b> 25 x 8,30 cm <b>Envase:</b> 1 caja = 0,83 m <sup>2</sup>

## listello facciavista



listello facciate estruso in cotto	extruded brick facades strip	tira de fachadas de ladrillo extrusionado
Listello estruso in cotto tipo Style Terremilia o tipo Fornace Fosdondo.	Extruded terracotta slip, such as Style Terremilia or Fornace Fosdondo.	Listel extruido en barro cocido tipo Style Terremilia o tipo Fornace Fosdondo.
<b>Per sistema:</b> Termok8 Modular Facciavista <b>Dimensioni:</b> 24,5 x 5,5 x 1,6 cm <b>Confezione:</b> 1 m <sup>2</sup> = 60 pezzi	<b>For the system:</b> Termok8 Modular Facciavista <b>Size:</b> 24.5 x 5.5 x 1.6 cm <b>Package:</b> 1 m <sup>2</sup> = 60 pieces	<b>Para sistema:</b> Termok8 Modular Facciavista <b>Medidas:</b> 24,5 x 5,5 x 1,6 cm <b>Envase:</b> 1 m <sup>2</sup> = 60 piezas
Versione angolare del Listello Facciavista.	Corner version of Facciavista slip.	Versión angular del listel Facciavista.
<b>Dimensioni:</b> 24,5 x 5,5 x 11,7 x 1,6 cm <b>Confezione:</b> 1 m = 15 pezzi	<b>Size:</b> 24.5 x 5.5 x 11.7 x 1.6 cm <b>Package:</b> 1 m = 15 pieces	<b>Medidas:</b> 24,5 x 5,5 x 11,7 x 1,6 cm <b>Envase:</b> 1 m = 15 piezas

## listello a mano san marco



listello facciavista in cotto in pasta	exposed brick slat in pasta	tira expuesta en pasta cocida
Listello in cotto a mano San Marco.	San Marco handmade terracotta slip.	Listel en barro cocido a mano San Marco.
<b>Per sistema:</b> Termok8 Modular Facciavista <b>Dimensioni:</b> 25 x 5,5 x 2 cm <b>Confezione:</b> 1 m <sup>2</sup> = 60 pezzi	<b>For the system:</b> Termok8 Modular Facciavista <b>Size:</b> 25 x 5.5 x 2 cm <b>Package:</b> 1 m <sup>2</sup> = 60 pieces	<b>Para sistema:</b> Termok8 Modular Facciavista <b>Medidas:</b> 25 x 5,5 x 2 cm <b>Envase:</b> 1 m <sup>2</sup> = 60 piezas
Versione angolare del Listello a mano San Marco.	Corner version of San Marco handmade slip.	Versión angular del Listel a mano San Marco.
<b>Dimensioni:</b> 25 x 5,5 h x 12 x 2 cm <b>Confezione:</b> 1 m = 15 pezzi	<b>Size:</b> 25 x 5.5 h x 12 x 2 cm <b>Package:</b> 1 m = 15 pieces	<b>Medidas:</b> 25 x 5,5 h x 12 x 2 cm <b>Envase:</b> 1 m = 15 piezas

## listello flex

 scheda  
tecnica

 data  
sheet

 ficha  
técnica

listello effetto facciavista a basso modulo elastico	exposed-effect strip with low modulus of elasticity	tira de efecto visto con bajo módulo de elasticidad
<b>Per sistema:</b> Termok8 Flex e Modular Flex L.R.	<b>For the system:</b> Termok8 Flex and Modular Flex L.R.	<b>Para sistema:</b> Termok8 Flex y Modular Flex L.R.
<b>Dimensioni:</b> 24x 5,2 cm <b>Colori Classici:</b> Rosso Sahara - Rosso Toscana - bianco (per m. con fuga da 12 mm) <b>Confezione:</b> da 2 m <sup>2</sup> inclusa fuga da 12 mm.	<b>Size:</b> 24x 5.2 cm <b>Classic Colours:</b> Sahara Red - Tuscan Red - white (for 12 mm joint) <b>Package:</b> 2 m <sup>2</sup> including 12 mm joint.	<b>Medidas:</b> 24x 5,2 cm <b>Colores Clásicos:</b> Rojo Sahara - Rojo Toscana - blanco (para m. con fuga de 12 mm) <b>Envases:</b> de 2 m <sup>2</sup> incluida la junta de 12 mm.
Angolari	Corner version	Angulares
<b>Colori Classici:</b> Rosso Sahara - Rosso Toscana - bianco (per m. con fuga da 12 mm) <b>Confezione:</b> da 1,5 m. inclusa fuga da 12 mm.	<b>Classic Colours:</b> Sahara Red - Tuscan Red - white (for 12 mm joint) <b>Package:</b> 1,5 m including 12 mm joint.	<b>Colores Clásicos:</b> Rojo Sahara - Rojo Toscana - blanco (para m. con fuga de 12 mm) <b>Envases:</b> de 1,5 m. incluida fuga de 12 mm.







Elementi decorativi sagomati in EPS (a norma UNI EN 13163) prerasati con malte fibrate. Specifici per applicazioni esterne; sovraverniciabili. Oltre alle proposte standard, possono essere realizzati profili personalizzati nella forma e nelle dimensioni in funzione delle esigenze tecniche ed estetiche del progetto, garantendo la massima flessibilità di un sistema Termok8 su misura.

Shaped, decorative elements in EPS (compliant with UNI EN 13163) preskimmed with fibrous mortar. Specific for external applications. They can be overpainted. Besides the standard products, profile size and shape can be customized to meet the technical and aesthetic requirements of the project, thus guaranteeing utmost flexibility for a custom Termok8 system.

Elementos decorativos perfilados en EPS (conforme a la norma UNI EN 13163) con enrasado previo con morteros fibrados. Específicos para aplicaciones externas; admiten recubrimiento de pintura. Además de las propuestas estándar, pueden realizarse perfiles personalizados en la forma y en las Dimensiones en función de las necesidades técnicas y estéticas del proyecto, garantizando la máxima flexibilidad de un sistema Termok8 a medida.

## cornice sottogronda - under gutter cornice - cornisa bajo canaletta

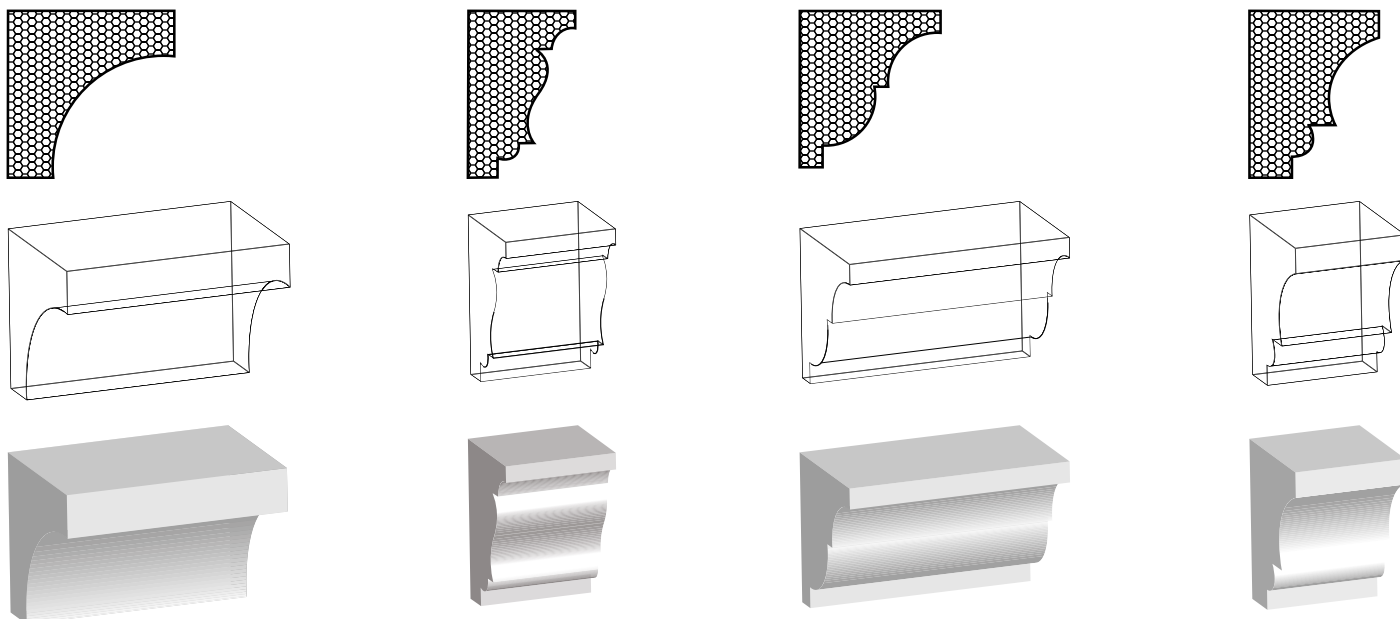

## marcapiano - string course - imposta

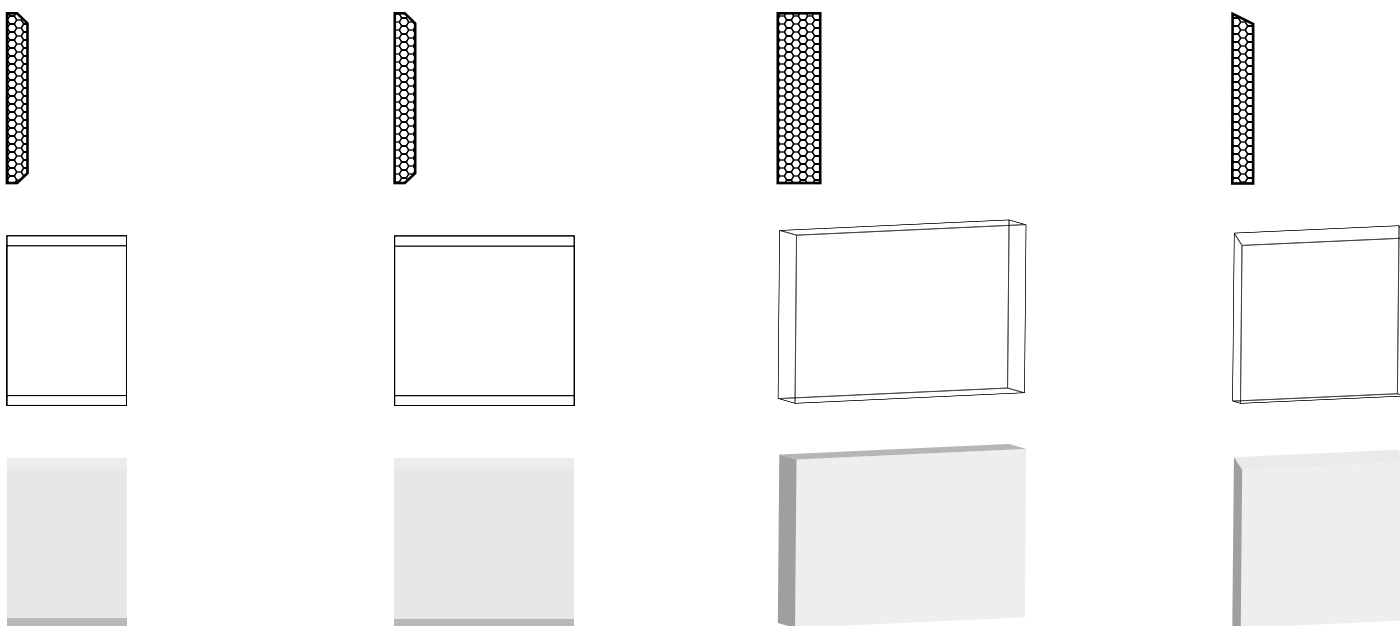

**decoro lineare - linear decoration - decoración lineal**

---

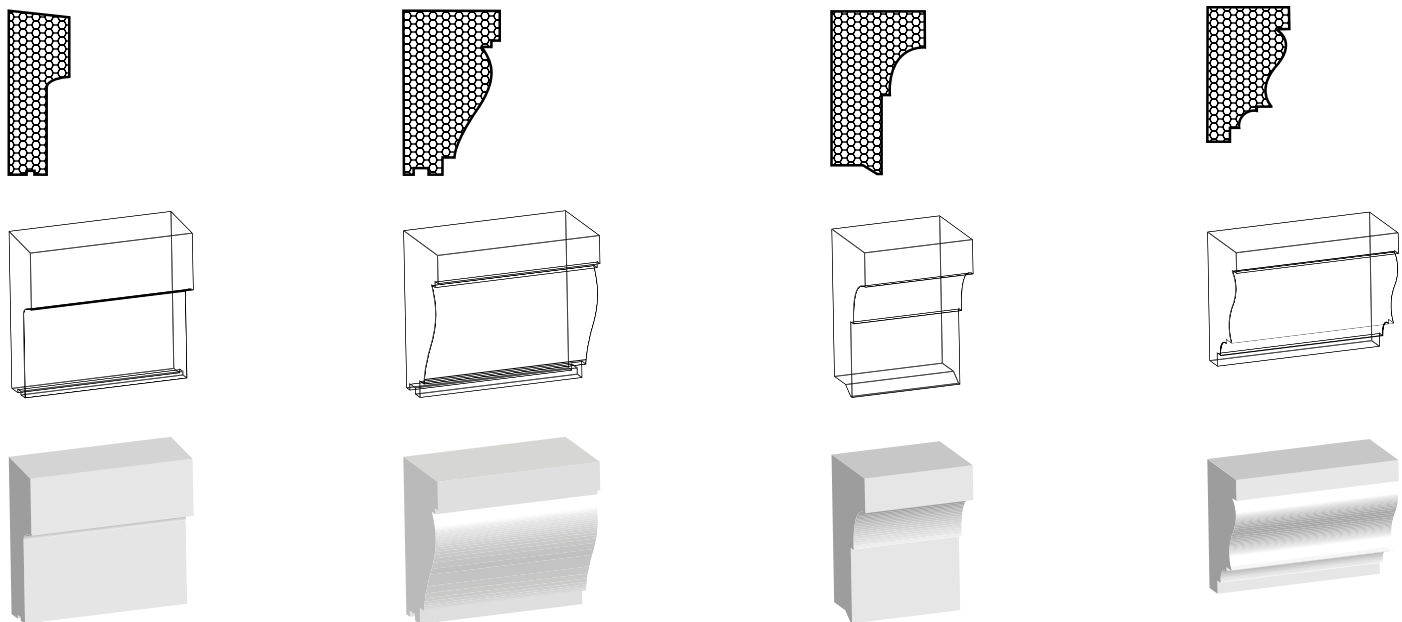
**bugna - rusticated ashlar - almohadilla**

---

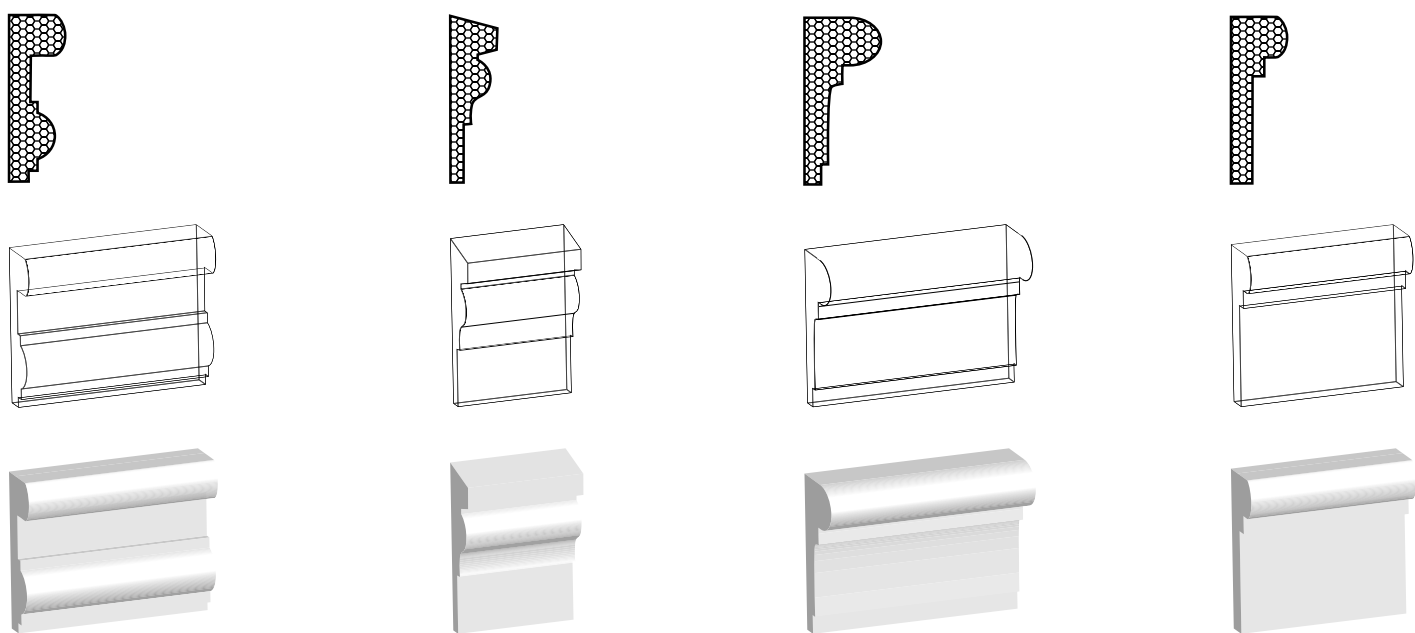

## punta per trapano high speed



punta speciale per la foratura veloce e sicura di laterizi forati	special drill bit for fast, safe drilling of hollow brick	punta especial para perforación rápida y segura de ladrillos huecos
Punta per foratura veloce di laterizi forati. Permette una riduzione dei tempi di foratura e della forza impiegata. Migliora fino al 60% la resistenza alla trazione del tassello rispetto alla foratura con le normali punte.	Bit for fast drilling of hollow bricks. It reduces drilling time and force required. It improves anchor tensile strength by 60% over drilling with standard bits.	Punta para perforación rápida de ladrillos huecos. Permite una reducción de los tiempos de perforación y de la fuerza empleada. Mejora hasta el 60 % la resistencia a la tracción del taco con respecto a la perforación con las puntas normales.
<b>Eventuale confezione:</b> 10 pezzi	<b>Package:</b> 10 pieces	<b>Envase</b> (en su caso): 10 piezas

## fresa per risanamento STR



fresa per asportazione puntuale del rivestimento a spessore della rasatura armata	milling cutter for removal of thick reinforced skim coat	fresa para retirada puntual del revestimiento de espesor del enrasado armado
Fresa per il consolidamento di sistemi a cappotto esistenti. Pensata per asportare lo strato di finitura esterna e la rete di armatura permettendo di montare tasselli ad incasso o a percussione.	milling cutter for consolidation of existing external thermal insulation systems. Designed to remove the outer topcoat and reinforcement mesh, making it possible to install recessed or percussion anchors.	Fresa para consolidación de sistemas por capas existentes. Pensada para retirar la capa de acabado externo y la malla de armadura permitiendo montar tacos encajados o de percusión.

## fresa per risanamento PTZ



fresa per asportazione puntuale del rivestimento a spessore	milling cutter for removal of thick coating	fresa para retirada puntual del revestimiento de espesor
Fresa per il consolidamento di sistemi a cappotto esistenti. Pensata per asportare solo lo strato di finitura esterna ed andare a tassellare il sistema attraverso la rete di armatura, sia con tasselli a percussione che ad avvitamento.	milling cutter for consolidation of existing external thermal insulation systems. Designed to remove only the outer topcoat and then anchor the system through the reinforcement mesh with either percussion or screw anchors.	Fresa para consolidación de sistemas por capas existentes. Pensada para retirar solo la capa de acabado externo para aplicar los tacos al sistema a través de la malla de armadura, con tacos que pueden ser de percusión o de rosca.
Fornita in un unico pezzo con testina di taglio già montata.	Supplied in one piece with cutting head already fitted.	Se entrega en una única pieza con cabezal de corte ya montado.

## inserto per il montaggio CT 2G



bit specifico per il montaggio a filo esterno del tassello CT 2G	specific bit for flush surface mounting of the CT 2G anchor	punta bit specifica para el montaje al ras externo del taco CT 2G
Strumento specifico per applicazione sulla testa dell'avvitatore, dotato di vite Torx per l'applicazione dei tasselli CT 2G.	Tool designed for application on the screw head, fit with a Torx screw for the application of CT 2G anchors.	Herramienta específica para aplicación en la cabeza del atornillador, dotado de tornillo Torx para la aplicación de los tacos CT 2G.
<b>Lunghezza disponibile:</b> 90 mm e 200mm <b>Eventuale confezione:</b> 10 pezzi	<b>Available lengths:</b> 90 mm and 200mm <b>Package:</b> 10 pieces	<b>Largo disponible:</b> 90 mm y 200 mm <b>Envase</b> (en su caso): 10 piezas

## inserto per il montaggio CT L



bit specifico per il montaggio a filo esterno del tassello CT L	specific bit for flush surface mounting of the CT L anchor	punta bit specifica para el montaje al ras externo del taco CT L
Strumento specifico per applicazione sulla testa dell'avvitatore, dotato di vite Torx per l'applicazione dei tasselli CT L.	Tool designed for application on the screw head, fit with a Torx screw for the application of CT L anchors.	Herramienta específica para aplicación en la cabeza del destornillador, equipada con un tornillo Torx para la aplicación de los tacos CT L.
<b>Lunghezza disponibile:</b> 50 mm	<b>Available lengths:</b> 50 mm	<b>Largo disponible:</b> 50 mm

## inserto per il montaggio CT S1



bit specifico per il montaggio a filo esterno del tassello CT S1	specific bit for flush surface mounting of the CT S1 anchor	punta bit específica para el montaje al ras externo del taco CT S1
Strumento specifico per applicazione sulla testa dell'avvitatore, dotato di vite Torx per l'applicazione dei tasselli CT S1.	Tool designed for application on the screw head, fit with a Torx screw for the application of CT S1 anchors.	Herramienta específica para aplicación en la cabeza del atornillador, dotado de tornillo Torx para la aplicación de los tacos CT S1.

## talpa per tassello CT 2G - CT L



talpa per tasselli CT 2G e CT L	circular drill bit for CT 2 G and CT L anchors	rosetta di fijación para tacos CT 2 G y CT L
Utensile specifico per il montaggio incassato dei tasselli CT 2 G e CT L.	Tool for perfect flush surface mounting of the CT 2 G and CT L anchor	Herramienta para un perfecto montaje al ras de los tacos CT 2 G y CT L
<b>Kit costituito da:</b> utensile, testine di taglio, avvitatore angolare, bits per l'avvitamento.	<b>Kit consisting of:</b> tool, cutting heads, angle screwdriver, bits for screwing.	<b>Kit compuesto por:</b> herramienta, cabezales de corte, destornillador angular, puntas para atornillar.

## talpa per tassello CT S1



talpa per tasselli CT S1	circular drill bit for CT S1 anchors	rosetta di fijación para tacos CT S1
Utensile per un perfetto montaggio a filo del tassello CT S1	Tool for perfect flush mounting of the CT S1 anchors	Herramienta para un perfecto montaje enrasado del taco CT S1

## kit ricambi per talpa - CT 2G e CT L



per talpa per tasselli CT 2G e CT L	for circular drill bit for CT 2G and CT L anchors	para rosetta di fijación para tacos CT 2G y CT L
Include 3 testine di taglio e 3 bits per l'avvitamento nel montaggio ad incasso.	Includes 3 cutting heads and 3 bits for screwing into recessed mounting.	Incluye 3 cabezales de corte y 3 puntas bit para atornillado en el montaje empotrado.

## spatola sagomata



spatola speciale sagomata per rasature di fughe	special shaped spatula for skimming joints	espátula especial perfilada para enrasados de juntas
Spatolina opportunamente sagomata con specifici kit di accessori per la rasatura di fughe decorative eseguite con rete presagomata di tipo I (trapezio stretta), tipo II (trapezio larga) tipo III (triangolo).	Specially shaped spatula with kit of specific accessories for skimming decorative joints made with type I (trapezoidal - narrow), type II (trapezoidal - wide) and type III (triangular) shaped reinforcement mesh.	Espátula convenientemente perfilada con kit de accesorios específicos para el enrasado de juntas decorativas realizadas con malla previamente perfilada de tipo I (trapezio estrecha), tipo II (trapezio ancha) tipo III (triángulo).

## tagliatrice per eps da ponteggio



tagliatrice a caldo per il taglio preciso di pannelli in eps	hot cutter for precise cutting of EPS panels	cizalla en caliente para el corte preciso de paneles en eps
Tagliatrice a caldo per il taglio professionale di pannelli isolanti in EPS. Il pannello di comando, comodo e maneggevole, assicura tagli rapidi, precisi e puliti. Staffe per tagliare orientabili per effettuare facilmente tagli obliqui. Ideale da utilizzare su impalcature. Utilizzabile anche come apparecchio da tavolo.	Hot cutter for professional cutting of EPS insulating panels. The convenient, easy-to-use control panel ensures rapid, clean precision cutting. Adjustable brackets make cutting on the diagonal easy. Ideal for use on scaffolding. Can also be used as a table unit.	Cizalla en caliente para el corte profesional de paneles aislantes en EPS. El panel de mando, cómodo y manejable, asegura cortes rápidos, precisos y limpios. Bidas de corte orientables para efectuar fácilmente cortes oblicuos. Ideal para su uso sobre andamio. Utilizable también como aparato de mesa.
<b>Lunghezza massima:</b> 105 cm, profondità massima 25 cm.	<b>Maximum Length:</b> 105 cm, maximum depth 25 cm.	<b>Largo máxima:</b> 105 cm, profundidad máxima 25 cm.



**IVAS**®

**INDUSTRIA  
VERNICI**

---

DIVISIONE  
MALTE TECNICHE



**MAL  
TE  
TEC  
NI  
CHE**



**ripri sti**

# prodotti

towerip

towerip 108

towerip colabile

towerip betoncino

towcem

griptow

towerip rapido

towerip & finish



# no cls

## towerip

scheda  
tecnicadata  
sheetficha  
técnica

malta fibrorinforzata antiritiro - R3	<b>interno esterno</b>	anti-shrinkage, fibre- reinforced mortar -R3	<b>indoor outdoor</b>	mortero fibrorreforzado anti- retracción R3	<b>interior exterior</b>
Miscela cementizia pronta all'uso, a base di cementi e sabbie industriali con granulometria max di 1,2 mm, armata con fibre poliammidiche. Idonea per ripristini verticali gli strati applicati risultano di altissima adesione, durabilità, impermeabilità, di eccezionali resistenze meccaniche e agli attacchi chimici, e praticamente privi di ritiro, resistente ai cicli di gelo e disgelo. Per uso professionale.		Ready to use cement based mixture composed of cement and industrial sands (max. particle size of 1.2 mm) and reinforced with polyamide fibres. Suitable for vertical restorations, the applied layers have very high adhesion, durability, impermeability, exceptional mechanical and chemical resistance, and practically no shrinkage, resistant to freeze and thaw cycles. For professional use.		Mezcla a base de cemento lista para usar, a base de cementos y arenas industriales; granulometría máx. 1,2 mm, armado con fibras poliamídicas. Adecuado para restauraciones verticales, las capas aplicadas tienen muy alta adherencia, durabilidad, impermeabilidad, excepcional resistencia mecánica y química, y prácticamente ninguna contracción, resistente a los ciclos de congelación y descongelación. Para uso profesional.	
<b>Granulometria:</b> max 1,2 mm <b>Attrezzatura:</b> spatola, cazzuola, agitatore a basso numero di giri <b>Rapporto di miscelazione:</b> acqua - 17% <b>Consumo:</b> 19 kg/m <sup>2</sup> per cm di spessore <b>Colore:</b> grigio		<b>Particle size:</b> max 1,2 mm <b>Equipment:</b> spatula, trowel, mechanical low speed mixer <b>Mixing Ratio:</b> water - 17% <b>Coverage:</b> 19 kg/m <sup>2</sup> per mm of thickness <b>Color:</b> grey		<b>Granulometría:</b> max 1,2 mm <b>Herramientas:</b> espátula, paleta, agitador mecánico de bajo número de revoluciones <b>Proporción de mezcla:</b> agua - 17% <b>Consumo:</b> 19 kg/m <sup>2</sup> per cm de espesor <b>Color:</b> gris	

tecniche	certificazioni	proprietà	tecnologie
 WATER BASED  TROWEL			

## towerip 108

scheda  
tecnicadata  
sheetficha  
técnica

malta fibrorinforzata antiritiro - R4	<b>interno esterno</b>	anti-shrinkage, fibre- reinforced mortar -R4	<b>indoor outdoor</b>	mortero fibrorreforzado anti- retracción - R4	<b>interior exterior</b>
Miscela cementizia pronta all'uso, a base di cementi e sabbie industriali con granulometria max di 3 mm, armata con fibre poliammidiche. Idonea per ripristini verticali gli strati applicati risultano di altissima adesione, durabilità, impermeabilità, di eccezionali resistenze meccaniche e agli attacchi chimici, e praticamente privi di ritiro, resistente ai cicli di gelo e disgelo. Per uso professionale.		Ready to use cement based mixture composed of cement and industrial sands (max. particle size of 3 mm) and reinforced with polyamide fibres. Suitable for vertical restorations, the applied layers have very high adhesion, durability, impermeability, exceptional mechanical and chemical resistance, and practically no shrinkage, resistant to freeze and thaw cycles. For professional use.		Mezcla a base de cemento lista para usar, a base de cementos y arenas industriales; granulometría máx. 3 mm, armado con fibras poliamídicas. Adecuado para restauraciones verticales, las capas aplicadas tienen muy alta adherencia, durabilidad, impermeabilidad, excepcional resistencia mecánica y química, y prácticamente ninguna contracción, resistente a los ciclos de congelación y descongelación. Para uso profesional.	
<b>Granulometria:</b> max 3 mm <b>Attrezzatura:</b> spatola, cazzuola, agitatore a basso numero di giri <b>Rapporto di miscelazione:</b> acqua - 18% <b>Consumo:</b> 18 kg/m <sup>2</sup> per cm di spessore <b>Colore:</b> grigio		<b>Particle size:</b> max 3 mm <b>Equipment:</b> spatula, trowel, mechanical low speed mixer <b>Mixing Ratio:</b> water - 18% <b>Coverage:</b> 18 kg/m <sup>2</sup> per mm of thickness <b>Color:</b> grey		<b>Granulometría:</b> max 3 mm <b>Herramientas:</b> espátula, paleta, agitador mecánico de bajo número de revoluciones <b>Proporción de mezcla:</b> agua - 18% <b>Consumo:</b> 18 kg/m <sup>2</sup> per cm de espesor <b>Color:</b> gris	

tecniche	certificazioni	proprietà	tecnologie
 WATER BASED  TROWEL			

## towerip colabile



scheda  
tecnica



data  
sheet



ficha  
técnica



malta fluida colabile a ritiro controllato - R4	<b>esterno</b>	fluid mortar with controlled shrinkage -R4	<b>outdoor</b>	mortero fluido de contracción controlada - R4	<b>exterior</b>
Miscela cementizia pronta all'uso per ripristini verticali in cassero, a base di cementi e sabbie naturali, armata con fibre polipropilene. Gli strati applicati risultano di altissima adesione, durabilità, impermeabilità, di eccezionali resistenze meccaniche ed agli attacchi chimici, e praticamente priva di ritiro. Per uso professionale.		Ready-to-use cement-based mixture for vertical repairs in formworks, composed of cements and natural sands and reinforced with polypropylene fibres. The layers applied adhere perfectly and offer durability, impermeability and exceptional mechanical and chemical resistance and are practically free of any shrinkage. For professional use.		Mezcla de cemento lista para usar para renovaciones verticales sobre encofrado, a base de cementos y arenas naturales, armado con fibras polipropilénicas. Las capas aplicadas ofrecen gran adhesión, durabilidad, impermeabilidad, de excepcionales resistencias mecánicas y a los ataques químicos, prácticamente carentes de retracción. Para uso profesional.	
<b>Granulometria:</b> max 3 mm <b>Attrezzatura:</b> spatola, cazzuola, agitatore a basso numero di giri <b>Rapporto di miscelazione:</b> acqua - 15% <b>Consumo:</b> 20 kg/m <sup>2</sup> per cm di spessore <b>Colore:</b> grigio		<b>Particle size:</b> max 3 mm <b>Equipment:</b> spatula, trowel, mechanical low speed mixer <b>Mixing Ratio:</b> water - 15% <b>Coverage:</b> 20 kg/m <sup>2</sup> per mm of thickness <b>Color:</b> grey		<b>Granulometría:</b> max 3 mm <b>Herramientas:</b> espátula, paleta, agitador mecánico de bajo número de revoluciones <b>Proporción de mezcla:</b> agua - 15% <b>Consumo:</b> 20 kg/m <sup>2</sup> per cm de espesor <b>Color:</b> gris	

tecniche			certificazioni	proprietà			tecnologie		

## towerip betoncino



scheda  
tecnica



data  
sheet



ficha  
técnica



malta tixotropica ad applicazione meccanica - R3	<b>esterno</b>	tixotropic mortar for mechanical application -R3	<b>outdoor</b>	mortero tixotrópico para aplicación mecánica - R3	<b>exterior</b>
Malta tixotropica antiritiro per ripristini verticali ad applicazione meccanica, a base di cementi e sabbie industriali con granulometria da 2,5-3 mm, armata con fibre poliammidiche. Idonea per rinforzare strutture deteriorate e per ripristino del calcestruzzo, ripristino di gallerie, piscine, serbatoi. Può essere applicato con prodotti osmotici Towerseal e Towpruf. Per uso professionale.		Anti-shrinkage tixotropic mortar for vertical repairs applied mechanically. Composed of cement and industrial sands (max. particle size of 2.5-3 mm) and reinforced with polyamide fibres. Suitable to reinforce deteriorated structures and restore concrete, repair tunnels, swimming pools, tanks. Can be applied with the osmotic products Towerseal and Towpruf. For professional use.		Mortero tixotrópico anti-retracción para renovaciones verticales de aplicación mecánica, a base de cementos y arenas industriales; granulometría 2,5-3 mm, armado con fibras poliamidicas. Idóneo para reforzar estructuras deterioradas y para reacondicionamiento del hormigón, reacondicionamiento de galerías, piscinas, depósitos. Puede aplicarse con productos osmóticos Towerseal y Towpruf. Para uso profesional.	
<b>Granulometria:</b> max 3 mm <b>Attrezzatura:</b> spatola, cazzuola, agitatore a basso numero di giri <b>Rapporto di miscelazione:</b> acqua - 14% <b>Consumo:</b> 19 kg/m <sup>2</sup> per cm di spessore <b>Colore:</b> grigio		<b>Particle size:</b> max 3 mm <b>Equipment:</b> spatula, trowel, mechanical low speed mixer <b>Mixing Ratio:</b> water - 14% <b>Coverage:</b> 19 kg/m <sup>2</sup> per mm of thickness <b>Color:</b> grey		<b>Granulometría:</b> max 3 mm <b>Herramientas:</b> espátula, paleta, agitador mecánico de bajo número de revoluciones <b>Proporción de mezcla:</b> agua - 14% <b>Consumo:</b> 19 kg/m <sup>2</sup> per cm de espesor <b>Color:</b> gris	

tecniche			certificazioni	proprietà			tecnologie		





**towcem**



scheda  
tecnica



data  
sheet



ficha  
técnica



malta rasante a basso spessore - R3	<b>interno esterno</b>	low thickness skimming mortar - R3	<b>indoor outdoor</b>	mortero de enrasado de bajo espesor - R3	<b>interior exterior</b>
Miscela cementizia fibrata con granulometria massima di 0,8mm, pronta all'uso perfettamente lavorabile, antiritiro di altissima adesione, impermeabilità e di notevole resistenza meccanica. La malta contiene piccolissime bolle d'aria chiuse che la rendono resistente a cicli di gelo e disgelo. Per uso professionale.		Fiber-reinforced cement mixture with a maximum grain size of 0.8mm, ready to use, perfectly workable, anti-shrinkage with very high adhesion, impermeability and considerable mechanical resistance. The mortar contains very small closed air bubbles which make it resistant to freeze and thaw cycles. For professional use.		Mezcla de cemento reforzado con fibras con una granulometría máxima de 0,8 mm, lista para usar, perfectamente trabajable, anti-encogimiento con muy alta adherencia, impenetrabilidad y considerable resistencia mecánica. El mortero contiene burbujas de aire cerradas muy pequeñas que lo hacen resistente a ciclos de congelación y descongelación. Para uso profesional.	
<b>Granulometria:</b> max 0,8 mm <b>Attrezzatura:</b> spatola, cazzuola, agitatore a basso numero di giri <b>Rapporto di miscelazione:</b> acqua - 18% <b>Consumo:</b> 1,6 kg/m <sup>2</sup> per mm di spessore <b>Colore:</b> grigio		<b>Particle size:</b> max 0,8 mm <b>Equipment:</b> spatula, trowel, mechanical low speed mixer <b>Mixing Ratio:</b> water - 18% <b>Coverage:</b> 1,6 kg/m <sup>2</sup> per mm of thickness <b>Color:</b> grey		<b>Granulometría:</b> max 0,8 mm <b>Herramientas:</b> espátula, paleta, agitador mecánico de bajo número de revoluciones <b>Proporción de mezcla:</b> agua - 18% <b>Consumo:</b> 1,6 kg/m <sup>2</sup> per mm de espesor <b>Color:</b> gris	

tecniche			certificazioni	proprietà			tecnologie		

**griptow**



scheda  
tecnica



data  
sheet



ficha  
técnica



boiaccia antiruggine passivante	<b>interno esterno</b>	rustproof, passivating grout	<b>indoor outdoor</b>	mechada antióxido pasivante	<b>interior exterior</b>
Prodotto in polvere a base di cementi modificati, inerti selezionati, leganti polimerici alcaliresistenti ed additivi specifici. Appositamente studiato per consentire una perfetta ri-alkalinizzazione o passivazione dei ferri d'armatura nel ripristino del calcestruzzo con malte della linea Towerip. Per uso professionale.		Powdered product with modified cements, selected inert materials, alkali-resistant polymeric binders and specific additives. Specially designed to allow a perfect re-alkalization or passivation of the reinforcing steel when renovating concrete with mortars from the TOWERIP line. For professional use.		Producto en polvo a base de cementos modificados, áridos seleccionados, aglutinantes poliméricos resistentes a los álcalis y aditivos específicos. Expresamente estudiado para permitir una perfecta realcalinización o pasivación de los hierros de armadura al restaurar el hormigón con morteros de la línea TOWERIP. Para uso profesional.	
<b>Granulometria:</b> max 0,5 mm <b>Attrezzatura:</b> pennello, spatola, impastatrice a basso numero di giri <b>Rapporto di miscelazione:</b> acqua - 32% <b>Consumo:</b> 1,7 kg/m <sup>2</sup> per mm di spessore <b>Colore:</b> rossastro		<b>Particle size:</b> max 0,5 mm <b>Equipment:</b> brush, spatula, low speed mixer <b>Mixing Ratio:</b> water - 32% <b>Coverage:</b> 1,7 kg/m <sup>2</sup> per mm of thickness <b>Color:</b> reddish		<b>Granulometría:</b> max 0,5 mm <b>Herramientas:</b> brocha, espátula, agitador mecánico de bajo número de revoluciones <b>Proporción de mezcla:</b> agua - 32% <b>Consumo:</b> 1,7 kg/m <sup>2</sup> per mm de espesor <b>Color:</b> rojizo	

tecniche			certificazioni	proprietà			tecnologie		



**rasanti**

# prodotti

rasaltow max grigio

rasaltow max bianco

rasaltow grigio

rasaltow bianco

rasaltow 108 bianco

rasaltow plus 1.0

rasaltow beton grigio

rasaltow beton bianco

# i ht

## rasaltow max grigio

scheda  
tecnicadata  
sheetficha  
técnica

rasante grigio fine universale - 0,5 mm	interno esterno	grey universal fine skim coat, 0.5 mm	indoor outdoor	mortero de enrasado gris fino universal - 0,5 mm	interior exterior
Rasante universale cementizio grigio grana 0,5 mm in polvere idoneo per ottenere finiture di tipo civile fine di ottima qualità su calcestruzzo, intonaci cementizi anche già pitturati, vecchi rivestimenti plastici, solai, predalles. Ideale per realizzare stuccature fino a 20 mm e successiva rasatura anche armata con Rete in Fibra di vetro Armatex C1. Per uso professionale		Powdered universal grey cement-based skim coat, with 0.5mm grain size, suitable for superb quality fine two-coat finishes on concrete, cement-based plasters, even when already painted, old plastic coatings, floors, and predalles plates. The ideal solution for plastering up to 20 mm thick and subsequent skim coats, also reinforced with Armatex C1 glass fibre mesh. For professional use		Mortero de cemento universal para enrasado, gris, grano de 0,5 mm, en polvo, adecuado para obtener acabados de revoco fino de excelente calidad sobre hormigón, enfoscados de cemento incluso ya pintados, revestimientos plásticos viejos, forjados, predalles. Ideal para emplastes de hasta 20 mm y posterior enrasado, incluso armado, con malla de fibra de vidrio Armatex C1. Para uso profesional.	
<b>Granulometria:</b> max 0,5 mm <b>Attrezzatura:</b> spatola, cazzuola, agitatore a basso numero di giri <b>Rapporto di miscelazione:</b> acqua - 24% <b>Consumo:</b> 1,4 kg/m <sup>2</sup> per mm di spessore <b>Colore:</b> grigio		<b>Particle size:</b> max 0,5 mm <b>Equipment:</b> spatula, trowel, mechanical low speed mixer <b>Mixing Ratio:</b> water - 24% <b>Coverage:</b> 1,4 kg/m <sup>2</sup> per mm of thickness <b>Color:</b> grey		<b>Granulometría:</b> max 0,5 mm <b>Herramientas:</b> espátula, paleta, agitador mecánico de bajo número de revoluciones <b>Proporción de mezcla:</b> agua - 24% <b>Consumo:</b> 1,4 kg/m <sup>2</sup> per mm de espesor <b>Color:</b> gris	

tecniche	certificazioni	proprietà	tecnologie
 WATER BASED  TROWEL	 EN 1504-2 MC-IR  EN 998-1 GPCS IV		

## rasaltow max bianco

scheda  
tecnicadata  
sheetficha  
técnica

rasante bianco fine universale - 0,5 mm	interno esterno	white universal fine skim coat, 0.5 mm	indoor outdoor	mortero de enrasado blanco fino universal - 0,5 mm	interior exterior
Rasante universale cementizio bianco grana 0,5 mm in polvere idoneo per ottenere finiture di tipo civile fine di ottima qualità su calcestruzzo, intonaci cementizi anche già pitturati, vecchi rivestimenti plastici, solai, predalles. Ideale per realizzare stuccature fino a 20 mm e successiva rasatura anche armata con Rete in Fibra di vetro Armatex C1. Per uso professionale		Powdered universal grey cement-based skim coat, with 0.5mm grain size, suitable for superb quality fine two-coat finishes on concrete, cement-based plasters, even when already painted, old plastic coatings, floors, and predalles plates. The ideal solution for plastering up to 20 mm thick and subsequent skim coats, also reinforced with Armatex C1 glass fibre mesh. For professional use		Mortero de cemento universal para enrasado, blanco, grano de 0,5 mm, en polvo, adecuado para obtener acabados de revoco fino de excelente calidad sobre hormigón, enfoscados de cemento incluso ya pintados, revestimientos plásticos viejos, forjados, predalles. Ideal para emplastes de hasta 20 mm y posterior enrasado, incluso armado, con malla de fibra de vidrio Armatex C1. Para uso profesional.	
<b>Granulometria:</b> max 0,5 mm <b>Attrezzatura:</b> spatola, cazzuola, agitatore a basso numero di giri <b>Rapporto di miscelazione:</b> acqua - 24% <b>Consumo:</b> 1,4 kg/m <sup>2</sup> per mm di spessore <b>Colore:</b> bianco		<b>Particle size:</b> max 0,5 mm <b>Equipment:</b> spatula, trowel, mechanical low speed mixer <b>Mixing Ratio:</b> water - 24% <b>Coverage:</b> 1,4 kg/m <sup>2</sup> per mm of thickness <b>Color:</b> white		<b>Granulometría:</b> max 0,5 mm <b>Herramientas:</b> espátula, paleta, agitador mecánico de bajo número de revoluciones <b>Proporción de mezcla:</b> agua - 24% <b>Consumo:</b> 1,4 kg/m <sup>2</sup> per mm de espesor <b>Color:</b> blanco	

tecniche	certificazioni	proprietà	tecnologie
 WATER BASED  TROWEL	 EN 1504-2 MC-IR  EN 998-1 GPCS IV		



## rasaltow grigio



scheda  
tecnica



data  
sheet



ficha  
técnica



rasante cementizio	<b>interno esterno</b>	cement-based skim coat	<b>indoor outdoor</b>	mortero de cemento	<b>interior exterior</b>
<p>Rasante cementizio in polvere a base di inerti selezionati, leganti idraulici, copolimeri vinilici ed additivi specifici. Dotato di ottima spatolabilità e riempimento. Idoneo per ottenere finiture di tipo civile di ottima qualità su calcestruzzo, intonaci cementizi anche già pitturati, vecchi rivestimenti plastici, cartongesso, solai, predalles. Adatto per uniformare irregolarità fino a 0,5 cm di spessore e per rasature armate con rete in fibra di vetro con appretto antialcalino. Per uso professionale.</p>		<p>Powdered cement-based skim coat made of selected inert materials, hydraulic binders, vinyl copolymers and specific additives. With superb spreadability and filling capacity. Suitable for superb quality two-coat finishes on concrete, cement-based plasters, even when already painted, old plastic coatings, plasterboard, floors, predalles plates. Ideal for smoothing out irregularities up to 0.5 cm thick and for glass fibre mesh reinforced skimming with anti-alkaline treatment. For professional use.</p>		<p>Cemento en polvo rasante a base de inertes seleccionados, aglutinantes hidráulicos, copolímeros vinílicos y aditivos específicos. Dotado de excelente espatolabilidad y llenado. Idóneo para obtener acabados de tipo civil de óptima calidad sobre hormigón, enlucidos de cementos ya pintados, viejos revestimientos plásticos, cartonyeso, losas, predalles. Adecuado para uniformar irregularidades de hasta 0,5 cm de espesor y para el afeitado armado con malla de fibra de vidrio con aplicación antialcalina. Para uso profesional.</p>	
<p><b>Granulometria:</b> max 0,8 mm <b>Attrezzatura:</b> spatola, cazzuola, agitatore a basso numero di giri <b>Rapporto di miscelazione:</b> acqua - 24% <b>Consumo:</b> 1,4 kg/m<sup>2</sup> per mm di spessore <b>Colore:</b> grigio</p>		<p><b>Particle size:</b> max 0,8 mm <b>Equipment:</b> spatula, trowel, mechanical low speed mixer <b>Mixing Ratio:</b> water - 24% <b>Coverage:</b> 1,4 kg/m<sup>2</sup> per mm of thickness <b>Color:</b> grey</p>		<p><b>Granulometría:</b> max 0,8 mm <b>Herramientas:</b> espátula, paleta, agitador mecánico de bajo número de revoluciones <b>Proporción de mezcla:</b> agua - 24% <b>Consumo:</b> 1,4 kg/m<sup>2</sup> per mm de espesor <b>Color:</b> gris</p>	

tecniche			certificazioni		proprietà			tecnologie		

## rasaltow bianco



scheda  
tecnica



data  
sheet



ficha  
técnica



rasante cementizio	<b>interno esterno</b>	cement-based skim coat	<b>indoor outdoor</b>	mortero de cemento para enrasado	<b>interior exterior</b>
<p>Rasante cementizio in polvere a base di inerti selezionati, leganti idraulici, copolimeri vinilici ed additivi specifici. Dotato di ottima spatolabilità e riempimento. Idoneo per ottenere finiture di tipo civile di ottima qualità su calcestruzzo, intonaci cementizi anche già pitturati, vecchi rivestimenti plastici, cartongesso, solai, predalles. Adatto per uniformare irregolarità fino a 0,5 cm di spessore e per rasature armate con rete in fibra di vetro con appretto antialcalino. Per uso professionale.</p>		<p>Powdered cement-based skim coat made of selected inert materials, hydraulic binders, vinyl copolymers and specific additives. With superb spreadability and filling capacity. Suitable for superb quality two-coat finishes on concrete, cement-based plaster, even if already painted, old plastic coatings, plasterboard, floors, predalles plates. Ideal for smoothing out irregularities up to 0.5 cm thick and for glass fibre mesh reinforced skimming with anti-alkaline treatment. For professional use.</p>		<p>Mortero de cemento para enrasado en polvo, a base de áridos seleccionados, aglutinantes hidráulicos, copolímeros vinílicos y aditivos específicos. Excelente facilidad para su extensión con espátula y para relleno. Adecuado para obtener acabados de revoco de excelente calidad sobre hormigón, enfoscados de cemento incluso ya pintados, revestimientos plásticos viejos, cartón yeso, forjados, predalles. Adecuado para uniformar irregularidades de hasta 0,5 cm de espesor y para enrasados armados con malla de fibra de vidrio con apresto antialcalino. Para uso profesional.</p>	
<p><b>Granulometria:</b> max 0,8 mm <b>Attrezzatura:</b> spatola, cazzuola, agitatore a basso numero di giri <b>Rapporto di miscelazione:</b> acqua - 24% <b>Consumo:</b> 1,4 kg/m<sup>2</sup> per mm di spessore <b>Colore:</b> bianco</p>		<p><b>Particle size:</b> max 0,8 mm <b>Equipment:</b> spatula, trowel, mechanical low speed mixer <b>Mixing Ratio:</b> water - 24% <b>Coverage:</b> 1,4 kg/m<sup>2</sup> per mm of thickness <b>Color:</b> white</p>		<p><b>Granulometría:</b> max 0,8 mm <b>Herramientas:</b> espátula, paleta, agitador mecánico de bajo número de revoluciones <b>Proporción de mezcla:</b> agua - 24% <b>Consumo:</b> 1,4 kg/m<sup>2</sup> per mm de espesor <b>Color:</b> blanco</p>	

tecniche			certificazioni		proprietà			tecnologie		

## rasaltow 108 bianco



scheda  
tecnica



data  
sheet



ficha  
técnica



rasante universale alleggerito con perlite - 1mm	<b>interno esterno</b>	universal skim coat lightened with 1mm beads	<b>indoor outdoor</b>	mortero de enrasado universal aligerado con microperlas - 1mm	<b>interior exterior</b>
Rasante in polvere a base di resine insaponificabili, cemento portland ad alta resistenza, silicato di alluminio espanso e sabbie selezionate. Possiede ottime caratteristiche adesivanti e resistenza ai cicli di gelo e disgelo. Ottima spatolabilità e riempimento, è specificamente idoneo per rasature, rasature armate a spessore con rete di rinforzo, su intonaci cavillati, cemento armato. Per uso professionale.		Powder skim coat made of unsaponifiable resins, high resistance Portland cement, expanded aluminium silicate and selected sands. It offers superb adhesive properties and resistance to freeze-thaw cycles. Given its superb filling and applicability properties, Rasaltow 108 is specifically suited to applying skim coats and thick mesh-reinforced skim coats, on cracked plaster and reinforced concrete. For professional use.		Mortero de enrasado en polvo a base de resinas insaponificables, cemento portland de alta resistencia, silicato de aluminio expandido y arenas seleccionadas. Posee excelentes características de adhesión y resistencia a los ciclos de hielo y deshielo. Rasaltow 108, con excelente facilidad para la extensión con espátula y relleno, es específicamente idóneo para enrasados, enrasados de espesor armados con malla de refuerzo, sobre encofrados cuarteados, hormigón armado.	
<b>Granulometria:</b> max 1 mm <b>Attrezzatura:</b> spatola, cazzuola, agitatore a basso numero di giri <b>Rapporto di miscelazione:</b> acqua - 32-34% <b>Consumo:</b> 1 kg/m <sup>2</sup> per m di spessore <b>Colore:</b> bianco		<b>Particle size:</b> max 1 mm <b>Equipment:</b> spatula, trowel, mechanical low speed mixer <b>Mixing Ratio:</b> water - 32-34% <b>Coverage:</b> 1 kg/m <sup>2</sup> per mm of thickness <b>Color:</b> white		<b>Granulometría:</b> max 1 mm <b>Herramientas:</b> espátula, paleta, agitador mecánico de bajo número de revoluciones <b>Proporción de mezcla:</b> agua - 32-34% <b>Consumo:</b> 1 kg/m <sup>2</sup> per m de espesor <b>Color:</b> blanco	

tecniche	certificazioni	proprietà	tecnologie
 	 		

## rasaltow plus 1.0



scheda  
tecnica



data  
sheet



ficha  
técnica



rasante universale bianco - 1 mm	<b>interno esterno</b>	universal skim coat - 1 mm	<b>indoor outdoor</b>	mortero de enrasado universal - 1 mm	<b>interior exterior</b>
Rasante universale cementizio grana 1mm in polvere idoneo per ottenere finiture di tipo civile medio di ottima qualità su calcestruzzo, intonaci cementizi anche già pitturati, vecchi rivestimenti plastici, solai, predalles. Ideale per realizzare stuccature fino a 30mm e successiva rasatura armata con Rete in Fibra di vetro Armatex C1. Per interno e esterno. Per uso professionale.		Powdered universal cement-based skim coat, with 1mm grain size, suitable for superb quality medium two-coat finishes on concrete, cement-based plasters, even when already painted, old plastic coatings, plasterboard, floors, predalles plates. The ideal solution for plastering up to 30 mm thick and subsequent skim coats reinforced with Armatex C1 glass fibre mesh. For professional use.		Mortero de cemento universal para enrasado, grano de 1 mm, en polvo, adecuado para obtener acabados de revoco medio de excelente calidad sobre hormigón, encofrados de cemento incluso ya pintados, revestimientos plásticos viejos, cartón-yeso, forjados, predalles. Ideal para realizar emplastes de hasta 30 mm y posteriores enrasados armados con Malla de fibra de vidrio Armatex C1. Para uso profesional.	
<b>Granulometria:</b> max 1 mm <b>Attrezzatura:</b> spatola, cazzuola, agitatore a basso numero di giri <b>Rapporto di miscelazione:</b> acqua - 24-26% <b>Consumo:</b> 1,4 kg/m <sup>2</sup> per mm di spessore <b>Colore:</b> bianco		<b>Particle size:</b> max 1 mm <b>Equipment:</b> spatula, trowel, mechanical low speed mixer <b>Mixing Ratio:</b> water - 24-26% <b>Coverage:</b> 1,4 kg/m <sup>2</sup> per mm of thickness <b>Color:</b> white		<b>Granulometría:</b> max 1 mm <b>Herramientas:</b> espátula, paleta, agitador mecánico de bajo número de revoluciones <b>Proporción de mezcla:</b> agua - 24-26% <b>Consumo:</b> 1,4 kg/m <sup>2</sup> per mm de espesor <b>Color:</b> blanco	

tecniche	certificazioni	proprietà	tecnologie
 			

## rasaltow beton grigio



scheda  
tecnica



data  
sheet



ficha  
técnica



rasante cementizio per CLS - 0,6 mm	<b>interno esterno</b>	cement-based skim coat for concrete - 0,6 mm	<b>indoor outdoor</b>	mortero de cemento para hormigón - 0,6 mm	<b>interior exterior</b>
Rasante cementizio in polvere a base di inerti selezionati, leganti idraulici, copolimeri vinilici ed additivi specifici. Idoneo per ottenere finiture di tipo civile di ottima qualità su calcestruzzo liscio, vecchi rivestimenti plastici (tipo graffiato), solai e predalles. Adatto per uniformare irregolarità fino a 5 mm di spessore e per rasature armate con rete in fibra di vetro con appretto antialcalino. Per uso professionale.		Powdered cement-based skim coat made of selected inert materials, hydraulic binders, vinyl copolymers and specific additives. Suitable for superb quality two-coat finishes on smooth concrete, old plastic coatings (with scratched effect), floors, and predalles plates. Ideal for smoothing out irregularities up to 5 mm thick and for glass fibre mesh reinforced skimming with anti-alkaline treatment. For professional use.		Mortero de cemento para enrasado en polvo, a base de áridos seleccionados, aglutinantes hidráulicos, copolímeros vinílicos y aditivos específicos. Adecuado para obtener acabados de revoco de excelente calidad sobre hormigón liso, revestimientos plásticos viejos (efecto rayado), forjados y predalles. Adecuado para uniformar irregularidades de hasta 5 mm de espesor y para enrasados armados con malla de fibra de vidrio con apresto antialcalino.	
<b>Granulometria:</b> max 0,6 mm <b>Attrezzatura:</b> spatola, cazzuola, agitatore a basso numero di giri <b>Rapporto di miscelazione:</b> acqua - 22-25% <b>Consumo:</b> 1,4 kg/m <sup>2</sup> per mm di spessore <b>Colore:</b> grigio		<b>Particle size:</b> max 0,6 mm <b>Equipment:</b> spatula, trowel, mechanical low speed mixer <b>Mixing Ratio:</b> water - 22-25% <b>Coverage:</b> 1,4 kg/m <sup>2</sup> per mm of thickness <b>Color:</b> grey		<b>Granulometría:</b> max 0,6 mm <b>Herramientas:</b> espátula, paleta, agitador mecánico de bajo número de revoluciones <b>Proporción de mezcla:</b> agua - 22-25% <b>Consumo:</b> 1,4 kg/m <sup>2</sup> per mm de espesor <b>Color:</b> gris	

tecniche			certificazioni			proprietà			tecnologie		

## rasaltow beton bianco



scheda  
tecnica



data  
sheet



ficha  
técnica



rasante cementizio per CLS - 0,6 mm	<b>interno esterno</b>	cement-based skim coat for concrete - 0,6 mm	<b>indoor outdoor</b>	mortero de cemento para hormigón - 0,6 mm	<b>interior exterior</b>
Rasante cementizio in polvere a base di inerti selezionati, leganti idraulici, copolimeri vinilici ed additivi specifici. Idoneo per ottenere finiture di tipo civile di ottima qualità su calcestruzzo liscio, vecchi rivestimenti plastici (tipo graffiato), solai e predalles. Adatto per uniformare irregolarità fino a 5 mm di spessore e per rasature armate con rete in fibra di vetro con appretto antialcalino. Per uso professionale.		Powdered cement-based skim coat made of selected inert materials, hydraulic binders, vinyl copolymers and specific additives. Suitable for superb quality two-coat finishes on smooth concrete, old plastic coatings (with scratched effect), floors, and predalles plates. Ideal for smoothing out irregularities up to 5 mm thick and for glass fibre mesh reinforced skimming with anti-alkaline treatment. For professional use.		Mortero de cemento para enrasado en polvo, a base de áridos seleccionados, aglutinantes hidráulicos, copolímeros vinílicos y aditivos específicos. Adecuado para obtener acabados de revoco de excelente calidad sobre hormigón liso, revestimientos plásticos viejos (efecto rayado), forjados y predalles. Adecuado para uniformar irregularidades de hasta 5 mm de espesor y para enrasados armados con malla de fibra de vidrio con apresto antialcalino. Para uso profesional.	
<b>Granulometria:</b> max 0,6 mm <b>Attrezzatura:</b> spatola, cazzuola, agitatore a basso numero di giri <b>Rapporto di miscelazione:</b> acqua - 22-25% <b>Consumo:</b> 1,4 kg/m <sup>2</sup> per mm di spessore <b>Colore:</b> bianco		<b>Particle size:</b> max 0,6 mm <b>Equipment:</b> spatula, trowel, mechanical low speed mixer <b>Mixing Ratio:</b> water - 22-25% <b>Coverage:</b> 1,4 kg/m <sup>2</sup> per mm of thickness <b>Color:</b> white		<b>Granulometría:</b> max 0,6 mm <b>Herramientas:</b> espátula, paleta, agitador mecánico de bajo número de revoluciones <b>Proporción de mezcla:</b> agua - 22-25% <b>Consumo:</b> 1,4 kg/m <sup>2</sup> per mm de espesor <b>Color:</b> blanco	

tecniche			certificazioni			proprietà			tecnologie		



**rasanti**

# prodotti

tow bn anticarbonatazione

tow bk grigio

tow bk bianco

tow bf

uniform grigio

uniform bianco

tow bn r grigio

tow bn r bianco



## tow bn anticarbonatazione

scheda  
tecnicadata  
sheetficha  
técnica

finitura a civile fine anticarbonatazione - 0,6 mm	<b>interno esterno</b>	anti-carbonation fine two-coat finish - 0,6 mm	<b>indoor outdoor</b>	acabado de revoco fino anticarbonatación - 0,6 mm	<b>interior exterior</b>
Rasante cementizio anticarbonatazione grana 0,6 mm in polvere a base di inerti selezionati, leganti idraulici, copolimeri vinilici ed additivi atti ad impedire la carbonatazione del calcestruzzo. Dotato di ottima spatolabilità e riempimento, idoneo per rasare calcestruzzo, intonaci cementizi stagionati, solai. Per uso professionale.		Powdered cement-based anti-carbonation skim coat 0,6 mm made of selected inert materials, hydraulic binders, vinyl copolymers and specific additives to prevent carbonation of the concrete. With superb spreadability and filling capacity, suitable for levelling concrete, set cement-based plasters, predalles, floors and to smooth out irregularities up to 1 cm thick. For professional use.		Mortero de enrasado de cemento anticarbonatación en polvo 0,6mm a base de áridos seleccionados, aglutinantes hidráulicos, copolímeros vinilicos y aditivos idóneos para impedir la carbonatación del hormigón. Dotado de excelente facilidad para aplicación con espátula y relleno, idóneo para enrasar hormigón, enfoscados de cemento fraguados, predalles y forjados, así como para uniformar irregularidades hasta 1 cm de espesor. Para uso profesional.	
<b>Granulometria:</b> max 0,6 mm <b>Attrezzatura:</b> spatola, cazzuola, agitatore a basso numero di giri <b>Rapporto di miscelazione:</b> acqua - 18-20% <b>Consumo:</b> 1,5 kg/m <sup>2</sup> per mm di spessore <b>Colore:</b> grigio		<b>Particle size:</b> max 0,6 mm <b>Equipment:</b> spatula, trowel, mechanical low speed mixer <b>Mixing Ratio:</b> water - 18-20% <b>Coverage:</b> 1,5 kg/m <sup>2</sup> per mm of thickness <b>Color:</b> grey		<b>Granulometría:</b> max 0,6 mm <b>Herramientas:</b> espátula, paleta, agitador mecánico de bajo número de revoluciones <b>Proporción de mezcla:</b> agua - 18-20% <b>Consumo:</b> 1,5 kg/m <sup>2</sup> per mm de espesor <b>Color:</b> gris	

tecniche	certificazioni	proprietà	tecnologie
 WATER BASED  TROWEL			

## tow bk grigio

scheda  
tecnicadata  
sheetficha  
técnica

finitura a civile media per CLS -1,2 mm	<b>interno esterno</b>	medium two-coat finish for concrete - 1,2 mm	<b>indoor outdoor</b>	acabado de revoco medio para hormigón -1,2 mm	<b>interior exterior</b>
Rasante cementizio in polvere grana 1,2 mm a base di inerti selezionati, leganti idraulici, copolimeri vinilici ed additivi specifici. Dotato di ottima spatolabilità e riempimento, idoneo per rasare calcestruzzo, intonaci cementizi stagionati, solai; per effettuare il riempimento dei giunti delle predalles, per uniformare irregolarità fino ad 1 cm di spessore. Per interno ed esterno. Per uso professionale.		Powdered cement-based skim coat grain size 1.2 mm made of selected inert materials, hydraulic binders, vinyl copolymers and specific additives. Has superb spreadability and filling capacity. Ideal for skimming concrete, set cement-based plaster, floors; for filling joints between predalles, smoothing out irregularities up to 1cm thick. For professional use.		Mortero de cemento para enrasado en polvo tamaño de grano 1,2 mm, con base de áridos seleccionados, aglutinantes hidráulicos, copolímeros vinilicos y aditivos específicos. Dotado de excelente facilidad para aplicación con espátula y para relleno, idóneo para enrasar hormigón, enfoscados de cemento fraguados, forjados; para efectuar el relleno de las juntas de los predalles, para uniformar irregularidades de hasta 1 cm de espesor. Para uso profesional.	
<b>Granulometria:</b> max 1,2 mm <b>Attrezzatura:</b> spatola, cazzuola, agitatore a basso numero di giri <b>Rapporto di miscelazione:</b> acqua - 20-22% <b>Consumo:</b> 1,4 kg/m <sup>2</sup> per mm di spessore <b>Colore:</b> grigio		<b>Particle size:</b> max 1,2 mm <b>Equipment:</b> spatula, trowel, mechanical low speed mixer <b>Mixing Ratio:</b> water - 20-22% <b>Coverage:</b> 1,4 kg/m <sup>2</sup> per mm of thickness <b>Color:</b> grey		<b>Granulometría:</b> max 1,2 mm <b>Herramientas:</b> espátula, paleta, agitador mecánico de bajo número de revoluciones <b>Proporción de mezcla:</b> agua - 20-22% <b>Consumo:</b> 1,4 kg/m <sup>2</sup> per mm de espesor <b>Color:</b> gris	

tecniche	certificazioni	proprietà	tecnologie
 WATER BASED  TROWEL	 		

## tow bk bianco



scheda  
tecnica



data  
sheet



ficha  
técnica



finitura a civile media per CLS -1,2 mm	<b>interno esterno</b>	medium two-coat finish for concrete - 1.2 mm	<b>indoor outdoor</b>	acabado de revoco medio para hormigón-1,2 mm	<b>interior exterior</b>
Rasante cementizio bianco in polvere grana 1,2 mm a base di inerti selezionati, leganti idraulici, copolimeri vinilici ed additivi specifici. Dotato di ottima spatolabilità e riempimento, idoneo per rasare calcestruzzo, intonaci cementizi stagionati, solai; per effettuare il riempimento dei giunti delle predalles, per uniformare irregolarità fino ad 1 cm di spessore. Per uso professionale.		Powdered cement-based skim coat grain size 1.2 mm made of selected inert materials, hydraulic binders, vinyl copolymers and specific additives. Has superb spreadability and filling capacity. Ideal for skimming concrete, set cement-based plaster, floors; for filling joints between predalles, smoothing out irregularities up to 1cm thick. For professional use.		Mortero de cemento para enrasado en polvo tamaño de grano 1,2 mm, con base de áridos seleccionados, aglutinantes hidráulicos, copolímeros vinílicos y aditivos específicos. Dotado de excelente facilidad para aplicación con espátula y para relleno, idóneo para enrasar hormigón, enfoscados de cemento fraguados, forjados; para efectuar el relleno de las juntas de los predalles, para uniformar irregularidades de hasta 1 cm de espesor. Para uso profesional.	
<b>Granulometria:</b> max 1,2 mm <b>Attrezzatura:</b> spatola, cazzuola, agitatore a basso numero di giri <b>Rapporto di miscelazione:</b> acqua - 20-22% <b>Consumo:</b> 1,4 kg/m <sup>2</sup> per mm di spessore <b>Colore:</b> bianco		<b>Particle size:</b> max 1,2 mm <b>Equipment:</b> spatula, trowel, mechanical low speed mixer <b>Mixing Ratio:</b> water - 20-22% <b>Coverage:</b> 1,4 kg/m <sup>2</sup> per mm of thickness <b>Color:</b> white		<b>Granulometría:</b> max 1,2 mm <b>Herramientas:</b> espátula , paleta, agitador mecánico de bajo número de revoluciones <b>Proporción de mezcla:</b> agua - 20-22% <b>Consumo:</b> 1,4 kg/m <sup>2</sup> per mm de espesor <b>Color:</b> blanco	

tecniche	certificazioni	proprietà	tecnologie
 	 		

## tow bf



scheda  
tecnica



data  
sheet



ficha  
técnica



rasante a finitura liscia	<b>interno esterno</b>	smooth-finish skim coat	<b>indoor outdoor</b>	mortero de enrasado de acabado liso	<b>interior exterior</b>
Rasante a finitura estremamente liscia, cementizio in polvere a base di inerti selezionati, leganti idraulici, copolimeri vinilici ed additivi specifici, dotato di ottima spatolabilità. Idoneo per rasare calcestruzzo, intonaci cementizi stagionati, predalles e come finitura per i rasanti Tow BK o Tow BN. Per interno ed esterno. Per uso professionale.		Extremely smooth powdered cement-based skim coat made of selected inert materials, hydraulic binders, vinyl copolymers and specific additives offering superb trowel applicability. Suitable to skim concrete, set cement-based plaster, predalles plates, as finishing for Tow BK or Tow BN skim coats. For professional use.		Mortero de enrasado de acabado extremadamente liso, de cemento en polvo a base de áridos seleccionados, aglutinantes hidráulicos, copolímeros vinílicos y aditivos específicos, dotado de excelente facilidad para la aplicación con espátula. Idóneo para enrasar hormigón, enfoscados de cemento fraguados, predalles y como acabado para los morteros de enrasado Tow BK o Tow BN. Para uso profesional.	
<b>Granulometria:</b> max 0,1 mm <b>Attrezzatura:</b> spatola, cazzuola, impastatrice a basso numero di giri <b>Rapporto di miscelazione:</b> acqua - 40% <b>Consumo:</b> 1,3 kg/m <sup>2</sup> per mm di spessore <b>Colore:</b> bianco		<b>Particle size:</b> max 0,1 mm <b>Equipment:</b> spatula, trowel, low speed mixer <b>Mixing Ratio:</b> water - 40% <b>Coverage:</b> 1,3 kg/m <sup>2</sup> per mm of thickness <b>Color:</b> white		<b>Granulometría:</b> max 0,1 mm <b>Herramientas:</b> espátula , paleta, agitador mecánico de bajo número de revoluciones <b>Proporción de mezcla:</b> agua - 40% <b>Consumo:</b> 1,3 kg/m <sup>2</sup> per mm de espesor <b>Color:</b> blanco	

tecniche	certificazioni	proprietà	tecnologie
 	 		

## uniform grigio

scheda  
tecnicadata  
sheetficha  
técnica

rasante fibrorinforzato uniformante - 0,6 mm	<b>interno esterno</b>	uniforming fibre- reinforced skim coat - 0,6 mm	<b>indoor outdoor</b>	mortero de enrasado fibrorreforzado uniformante - 0,6 mm	<b>interior exterior</b>
Rasante fibrorinforzato uniformante grigio grana 0,6 mm. Idoneo per rasare e stuccare intonaci cementizi vecchi (non sfarinanti), stagionati e nuovi. Permette di ottenere finiture di tipo a civile. Lo spessore massimo per una singola mano è di 3 mm; per ottenere spessori maggiori è necessario interporre tra la prima e la seconda mano una rete in fibra di vetro alcaloresistente Armatex C1. Per interno ed esterno. Per uso professionale.		Uniforming fibre-reinforced grey skim coat, with 0,6mm grain size. Suitable for skimming and filling old cement-based plasters (when not chalky), set plaster and new plaster. Achieves two-coat finishes. The maximum thickness of a single coat is 3 mm; greater thicknesses require installing an alkali-resistant glass fibre Armatex C1 mesh between the first and second coat. For professional use.		Mortero de enrasado fibrorreforzado uniformante gris de grano 0,6 mm. Idóneo para enrasar y emplatar enfoscados de cemento viejos (sin desintegración pulverulenta), fraguados y nuevos. Permite obtener acabados de revoco. El espesor máximo para una sola mano es de 3 mm; para obtener espesores mayores es necesario interponer entre la primera y la segunda mano una malla de fibra de vidrio alcalino-resistente Armatex C1. Para uso profesional.	
<b>Granulometria:</b> max 0,6 mm <b>Attrezzatura:</b> spatola, cazzuola, agitatore a basso numero di giri <b>Rapporto di miscelazione:</b> acqua - 22-24% <b>Consumo:</b> 1,5 kg/m <sup>2</sup> per mm di spessore <b>Colore:</b> grigio		<b>Particle size:</b> max 0,6 mm <b>Equipment:</b> spatula, trowel, mechanical low speed mixer <b>Mixing Ratio:</b> water - 22-24% <b>Coverage:</b> 1,5 kg/m <sup>2</sup> per mm of thickness <b>Color:</b> grey		<b>Granulometría:</b> max 0,6 mm <b>Herramientas:</b> espátula, paleta, agitador mecánico de bajo número de revoluciones <b>Proporción de mezcla:</b> agua - 22-24% <b>Consumo:</b> 1,5 kg/m <sup>2</sup> per mm de espesor <b>Color:</b> gris	

tecniche		certificazioni	proprietà			tecnologie		

## uniform bianco

scheda  
tecnicadata  
sheetficha  
técnica

rasante fibrorinforzato uniformante - 0,6 mm	<b>interno esterno</b>	uniforming fibre- reinforced skim coat - 0,6 mm	<b>indoor outdoor</b>	mortero de enrasado fibrorreforzado uniformante - 0,6 mm	<b>interior exterior</b>
Rasante fibrorinforzato uniformante bianco grana 0,6 mm. Idoneo per rasare e stuccare intonaci cementizi vecchi (non sfarinanti), stagionati e nuovi. Permette di ottenere finiture di tipo a civile. Lo spessore massimo per una singola mano è di 3 mm; per ottenere spessori maggiori è necessario interporre tra la prima e la seconda mano una rete in fibra di vetro alcaloresistente Armatex C1. Per uso professionale.		Uniforming fibre-reinforced grey skim coat, with 0,6mm grain size. Suitable for skimming and filling old cement-based plasters (when not chalky), set plaster and new plaster. Achieves two-coat finishes. The maximum thickness of a single coat is 3 mm; greater thicknesses require installing an alkali-resistant glass fibre Armatex C1 mesh between the first and second coat. For professional use.		Mortero de enrasado fibrorreforzado uniformante gris de grano 0,6 mm. Idóneo para enrasar y emplatar enfoscados de cemento viejos (sin desintegración pulverulenta), fraguados y nuevos. Permite obtener acabados de revoco. El espesor máximo para una sola mano es de 3 mm; para obtener espesores mayores es necesario interponer entre la primera y la segunda mano una malla de fibra de vidrio alcalino-resistente Armatex C1. Para uso profesional.	
<b>Granulometria:</b> max 0,6 mm <b>Attrezzatura:</b> spatola, cazzuola, agitatore a basso numero di giri <b>Rapporto di miscelazione:</b> acqua - 22-24% <b>Consumo:</b> 1,5 kg/m <sup>2</sup> per mm di spessore <b>Colore:</b> bianco		<b>Particle size:</b> max 0,6 mm <b>Equipment:</b> spatula, trowel, mechanical low speed mixer <b>Mixing Ratio:</b> water - 22-24% <b>Coverage:</b> 1,5 kg/m <sup>2</sup> per mm of thickness <b>Color:</b> white		<b>Granulometría:</b> max 0,6 mm <b>Herramientas:</b> espátula, paleta, agitador mecánico de bajo número de revoluciones <b>Proporción de mezcla:</b> agua - 22-24% <b>Consumo:</b> 1,5 kg/m <sup>2</sup> per mm de espesor <b>Color:</b> blanco	

tecniche		certificazioni	proprietà			tecnologie		

## tow bn r grigio



scheda  
tecnica



data  
sheet



ficha  
técnica



rasante a finitura civile fine - 0,6 mm	<b>interno esterno</b>	fine two-coat finish skim coat - 0.6 mm	<b>indoor outdoor</b>	rasante a acabado civile fine - 0,6 mm	<b>interior exterior</b>
<p>Rasante cementizio grigio in polvere grana 0,6 mm a base di inerti selezionati, leganti aerei, idraulici ed additivi specifici. Dotato di ottima spatolabilità e riempimento, idoneo per la rasatura di intonaci nuovi interni ed esterni. Spessore massimo applicabile a due mani: 5 mm. Per uso professionale.</p>		<p>Powdered cement-based grey skim coat, with 0.6mm grain size, made of selected inert materials, hydraulic and air binders, and specific additives. With superb spreadability and filling capacity, ideal for skimming new indoor and outdoor plasters. Maximum applicable thickness with two coats: 5 mm. For professional use.</p>		<p>Rasante cementicio gris en polvo grano 0,6 mm a base de inertes seleccionados, aglutinantes aéreos, hidráulicos y aditivos específicos. Dotado de excelente espatulabilidad y llenado, idóneo para el afeitado de nuevos enlucidos internos y externos. Espesor máximo aplicable a dos manos: 5 mm. Para uso profesional.</p>	
<p><b>Granulometria:</b> max 0,6 mm <b>Attrezzatura:</b> spatola, cazzuola, agitatore a basso numero di giri <b>Rapporto di miscelazione:</b> acqua - 22-24% <b>Consumo:</b> 1,5 kg/m<sup>2</sup> per mm di spessore <b>Colore:</b> grigio</p>		<p><b>Particle size:</b> max 0,6 mm <b>Equipment:</b> spatula, trowel, mechanical low speed mixer <b>Mixing Ratio:</b> water - 22-24% <b>Coverage:</b> 1,5 kg/m<sup>2</sup> per mm of thickness <b>Color:</b> grey</p>		<p><b>Granulometría:</b> max 0,6 mm <b>Herramientas:</b> espátula, paleta, agitador mecánico de bajo número de revoluciones <b>Proporción de mezcla:</b> agua - 22-24% <b>Consumo:</b> 1,5 kg/m<sup>2</sup> per mm de espesor <b>Color:</b> gris</p>	

tecniche			certificazioni	proprietà				tecnologie		

## tow bn r bianco



scheda  
tecnica



data  
sheet



ficha  
técnica



rasante a finitura civile fine - 0,6 mm	<b>interno esterno</b>	fine two-coat finish skim coat - 0.6 mm	<b>indoor outdoor</b>	rasante a acabado civile fine - 0,6 mm	<b>interior exterior</b>
<p>Rasante cementizio grigio in polvere grana 0,6 mm a base di inerti selezionati, leganti aerei, idraulici ed additivi specifici. Dotato di ottima spatolabilità e riempimento, idoneo per la rasatura di intonaci nuovi interni ed esterni. Spessore massimo applicabile a due mani: 5 mm. Per uso professionale.</p>		<p>Powdered cement-based grey skim coat, with 0.6mm grain size, made of selected inert materials, hydraulic and air binders, and specific additives. With superb spreadability and filling capacity, ideal for skimming new indoor and outdoor plasters. Maximum applicable thickness with two coats: 5 mm. For professional use.</p>		<p>Rasante cementicio gris en polvo grano 0,6 mm a base de inertes seleccionados, aglutinantes aéreos, hidráulicos y aditivos específicos. Dotado de excelente espatulabilidad y llenado, idóneo para el afeitado de nuevos enlucidos internos y externos. Espesor máximo aplicable a dos manos: 5 mm. Para uso profesional.</p>	
<p><b>Granulometria:</b> max 0,6 mm <b>Attrezzatura:</b> spatola, cazzuola, agitatore a basso numero di giri <b>Rapporto di miscelazione:</b> acqua - 22-24% <b>Consumo:</b> 1,5 kg/m<sup>2</sup> per mm di spessore <b>Colore:</b> bianco</p>		<p><b>Particle size:</b> max 0,6 mm <b>Equipment:</b> spatula, trowel, mechanical low speed mixer <b>Mixing Ratio:</b> water - 22-24% <b>Coverage:</b> 1,5 kg/m<sup>2</sup> per mm of thickness <b>Color:</b> white</p>		<p><b>Granulometría:</b> max 0,6 mm <b>Herramientas:</b> espátula, paleta, agitador mecánico de bajo número de revoluciones <b>Proporción de mezcla:</b> agua - 22-24% <b>Consumo:</b> 1,5 kg/m<sup>2</sup> per mm de espesor <b>Color:</b> blanco</p>	

tecniche			certificazioni	proprietà				tecnologie		





calce n



# prodotti

asfodelo rinzaffo antisale

asfodelo

asfodelo risanante

asfodelo 530 bianco

artemisia

artemisia rasopietra



# aturale

## asfodelo rinzafo antisale



scheda  
tecnica



data  
sheet



ficha  
técnica



malta da rinzafo antisale base calce idraulica - 3 mm	<b>interno esterno</b>	hydraulic lime-based anti-salt rough coat mortar - 3 mm	<b>indoor outdoor</b>	mortero de repello antisal a base de cal apagada - 3 mm	<b>interior exterior</b>
Malta da rinzafo Color Nocciola specifica per la realizzazione di rinzafo antisale a base di calce idraulica pura. Composta da calce idraulica, sabbie selezionate e additivi specifici atti a conferire al prodotto la caratteristica di "filtro antisale" e controllano il passaggio dei sali idrosolubili quali cloruri, nitrati e solfati eventualmente presenti nella muratura. Per uso professionale.		Hydraulic lime-based mortar specific for anti-salt rough coats. Composed of hydraulic lime, selected sands and specific additives that give the product "anti-salt filter" properties and control the passage of water-soluble salts such as chlorides, nitrates and sulphates that may be present in the masonry. For professional use.		Mortero de repellido específico para la realización de repello antisal a base de cal hidráulica pura. Compuesto de cal hidráulica, arenas seleccionadas y aditivos específicos con función de dar al producto la característica de "filtro antisal" y controlar el paso de sales hidrosolubles como cloruros, nitratos y sulfatos que pudieran existir en las paredes. Para uso profesional.	
<b>Granulometria:</b> max 2,5 mm <b>Attrezzatura:</b> spatola, cazzuola, betoniera, agitatore a basso numero di giri <b>Rapporto di miscelazione:</b> acqua - 22% <b>Consumo:</b> 15 kg/m <sup>2</sup> per cm di spessore <b>Colore:</b> nocciola		<b>Particle size:</b> max 2,5 mm <b>Equipment:</b> spatula, trowel, cement mixer, mechanical low speed mixer <b>Mixing Ratio:</b> water - 22% <b>Coverage:</b> 15 kg/m <sup>2</sup> per mm of thickness <b>Color:</b> hazelnut		<b>Granulometría:</b> max 2,5 mm <b>Herramientas:</b> espátula, paleta, hormigonera, agitador mecánico de bajo número de revoluciones <b>Proporción de mezcla:</b> agua - 22% <b>Consumo:</b> 15 kg/m <sup>2</sup> per cm de espesor <b>Color:</b> avellanado	

tecniche	certificazioni	proprietà	tecnologie
 WATER BASED  TROWEL	 EN 998-1 GPC CS II		

## asfodelo



scheda  
tecnica



data  
sheet



ficha  
técnica



intonaco premiscelato base calce idraulica - 1,2 mm	<b>interno esterno</b>	hydraulic lime-based plaster premix, 1,2 mm	<b>indoor outdoor</b>	enfoscado premezclado a base de cal hidráulica - 1,2 mm	<b>interior exterior</b>
Intonaco premiscelato Color Nocciola a base di calce idraulica naturale NHL 5 (conforme alla norma EN 459:2010), pozzolana micronizzata ed inerti selezionati. Appositamente studiato per un'ottima lavorabilità con applicazione meccanica. Adatto per intonaci interni ed esterni ecologici e di edifici di interesse storico e culturale. Spessore massimo applicabile 15 mm per mano. Per uso professionale.		Plaster premix based on natural hydraulic lime NHL 5 (in compliance with EN 459:2010), micronized pozzolana and selected inert materials, specifically designed for rational application. Suitable for eco-friendly plasters for indoor and outdoor application and for those of historic and cultural buildings. Maximum applicable thickness 15 mm per coat. For professional use.		Enfoscado premezclado a base de cal hidráulica natural NHL 5 (conforme a la norma EN 459:2010), puzolana micronizada y áridos seleccionados, expresamente estudiado para una aplicación racional. Idóneo para enfoscados internos y externos, ecológicos y de edificios de interés histórico y cultural. Espesor máximo aplicable 15 mm por mano. Para uso profesional.	
<b>Granulometria:</b> max 1,2 mm <b>Attrezzatura:</b> spatola, frattazzo, intonatrice meccanica, staggia, rabotto <b>Rapporto di miscelazione:</b> acqua - 20% <b>Consumo:</b> 14 kg/m <sup>2</sup> per cm di spessore <b>Colore:</b> nocciola		<b>Particle size:</b> max 1,2 mm <b>Equipment:</b> spatula, trowel, mechanical plastering machine, levelling bar, plaster plane <b>Mixing Ratio:</b> water - 20% <b>Coverage:</b> 14 kg/m <sup>2</sup> per mm of thickness <b>Color:</b> hazelnut		<b>Granulometría:</b> max 1,2 mm <b>Herramientas:</b> espátula, frattazzo, enfo-scadora mecánica, sregla, rabot <b>Proporción de mezcla:</b> agua - 20% <b>Consumo:</b> 14 kg/m <sup>2</sup> per cm de espesor <b>Color:</b> avellanado	

tecniche	certificazioni	proprietà	tecnologie
 WATER BASED  TROWEL  PLASTERING MACHINE	 EN 998-1 GPC CS II		













**collant**



# prodotti

glueflex grigio

glueflex bianco

glueflex hp grigio

glueflex hp bianco

glueflex ultra grigio

glueflex ultra bianco

ti

## glueflex grigio

scheda  
tecnicadata  
sheetficha  
técnica

adesivo cementizio grigio classe C2TE	<b>interno esterno</b>	cement-based grey adhesive, class C2TE	<b>indoor outdoor</b>	adhesivo cementoso gris clase C2TE	<b>interior exterior</b>
Adesivo cementizio grigio a prestazioni migliorate (C2) a scivolamento verticale nullo (T inferiore a 0,5mm). Tempo aperto allungato (E) per piastrelle in ceramica di medie dimensioni (300mm x 300 mm) e materiale lapideo. Per uso professionale.		Improved-performance, cement-based grey adhesive (C2) with no vertical slip (T less than 0.5 mm). Extended open time (E) for medium-sized ceramic tiles (300 mm x 300 mm) and stone. For professional use.		Adhesivo cementoso gris de prestaciones mejoradas (C2) con deslizamiento vertical nulo (T inferior a 0,5 mm). Tiempo abierto prolongado (E) para baldosas en cerámica de tamaño mediano (300 mm x 300 mm) y material lapideo. Para uso profesional.	
<b>Granulometria:</b> max 0,5 mm <b>Attrezzatura:</b> spatola dentata, cazzuola, impastatrice a basso numero di giri <b>Rapporto di miscelazione:</b> acqua - 26-28% <b>Consumo:</b> Mosaici piccoli formati 2 kg/m <sup>2</sup> - standard 2,5-3,5 kg/m <sup>2</sup> - grandi 4,5-5 kg/m <sup>2</sup> <b>Colore:</b> grigio		<b>Particle size:</b> max 0,5 mm <b>Equipment:</b> serrated spatula, trowel, low speed mixer <b>Mixing Ratio:</b> water - 26-28% <b>Coverage:</b> Small Mosaics 2 kg/m <sup>2</sup> - Standard sizes 2.5-3.5 kg/m <sup>2</sup> - Large formats 4.5-5 kg/m <sup>2</sup> <b>Color:</b> grey		<b>Granulometría:</b> max 0,5 mm <b>Herramientas:</b> espátula dentada, paleta, agitador mecánico de bajo número de revoluciones <b>Proporción de mezcla:</b> agua - 26-28% <b>Consumo:</b> Mosaicos de pequeño tamaño 2 kg/m <sup>2</sup> - estándar 2,5-3,5 kg/m <sup>2</sup> - grandes 4,5-5 kg/m <sup>2</sup> <b>Color:</b> gris	

tecniche	certificazioni	proprietà	tecnologie
 WATER BASED  TROWEL			

## glueflex bianco

scheda  
tecnicadata  
sheetficha  
técnica

adesivo cementizio bianco classe C2TE	<b>interno esterno</b>	adesivo cementizio white classe C2TE	<b>indoor outdoor</b>	adhesivo cementoso blanco clase C2TE	<b>interior exterior</b>
Adesivo cementizio bianco a prestazioni migliorate (C2) a scivolamento verticale nullo (T inferiore a 0,5mm). Tempo aperto allungato (E) per piastrelle in ceramica di medie dimensioni (300mm x 300 mm) e materiale lapideo. Per uso professionale.		Improved-performance, cement-based grey adhesive (C2) with no vertical slip (T less than 0.5 mm). Extended open time (E) for medium-sized ceramic tiles (300 mm x 300 mm) and stone. For professional use.		Adhesivo cementoso blanco de prestaciones mejoradas (C2) con deslizamiento vertical nulo (T inferior a 0,5 mm). Tiempo abierto prolongado (E) para baldosas en cerámica de tamaño mediano (300 mm x 300 mm) y material lapideo. Para uso profesional.	
<b>Granulometria:</b> max 0,5 mm <b>Attrezzatura:</b> spatola dentata, cazzuola, impastatrice a basso numero di giri <b>Rapporto di miscelazione:</b> acqua - 27-29% <b>Consumo:</b> Mosaici piccoli formati 2 kg/m <sup>2</sup> - standard 2,5-3,5 kg/m <sup>2</sup> - grandi 4,5-5 kg/m <sup>2</sup> <b>Colore:</b> bianco		<b>Particle size:</b> max 0,5 mm <b>Equipment:</b> serrated spatula, trowel, low speed mixer <b>Mixing Ratio:</b> water - 27-29% <b>Coverage:</b> Small Mosaics 2 kg/m <sup>2</sup> - Standard sizes 2.5-3.5 kg/m <sup>2</sup> - Large formats 4.5-5 kg/m <sup>2</sup> <b>Color:</b> white		<b>Granulometría:</b> max 0,5 mm <b>Herramientas:</b> espátula dentada, paleta, agitador mecánico de bajo número de revoluciones <b>Proporción de mezcla:</b> agua - 27-29% <b>Consumo:</b> Mosaicos de pequeño tamaño 2 kg/m <sup>2</sup> - estándar 2,5-3,5 kg/m <sup>2</sup> - grandes 4,5-5 kg/m <sup>2</sup> <b>Color:</b> blanco	

tecniche	certificazioni	proprietà	tecnologie
 WATER BASED  TROWEL			



## glueflex ultra grigio

scheda  
tecnicadata  
sheetficha  
técnica

adesivo cementizio grigio classe C2TE	interno esterno	flexible cement- based grey adhesive, class C2TE S1	indoor outdoor	adhesivo cementoso gris flexible clase C2TE S1	interior exterior
Adesivo cementizio grigio flessibile (S1) ad alte prestazioni (C2) a scivolamento verticale nullo (T inferiore a 0,5mm). Tempo aperto allungato (E) per piastrelle in ceramica e gres porcellanato di medie dimensioni (300mm x 300 mm), materiale lapideo, cotto e Klinker. Idoneo per incollaggio di ceramica e gres anche in grande formato a pavimento standard e per pavimenti riscaldati. Per uso professionale.		High-performance (C2), flexible (S1) cement-based grey adhesive with no vertical slip (T less than 0.5 mm). Extended open time (E) for medium-sized ceramic tiles and porcelain stoneware (300 mm x 300 mm), stone, terracotta, and klinker. Suitable for gluing ceramic and stoneware tiles, even in large sizes, to standard and heated floors. For professional use.		Adhesivo cementoso gris flexible (S1) de altas prestaciones (C2) con deslizamiento vertical nulo (T inferior a 0,5 mm). Tiempo abierto prolongado (E) para baldosas en cerámica y gres porcelánico de tamaño mediano (300 mm x 300 mm), material lapideo, barro cocido y klinker. Idóneo para encolado de cerámica y gres, incluso en formatos grandes, a suelos estándares y para suelos radiantes. Para uso profesional.	
<b>Granulometria:</b> max 0,5 mm <b>Attrezzatura:</b> spatola dentata, cazzuola, impastatrice a basso numero di giri <b>Rapporto di miscelazione:</b> acqua - 29-31% <b>Consumo:</b> Mosaici piccoli formati 2 kg/m <sup>2</sup> - standard 2,5-3,5 kg/m <sup>2</sup> - grandi 4,5-5 kg/m <sup>2</sup> <b>Color:</b> grigio		<b>Particle size:</b> max 0,5 mm <b>Equipment:</b> serrated spatula, trowel, low speed mixer <b>Mixing Ratio:</b> water - 29-31% <b>Coverage:</b> Small Mosaics 2 kg/m <sup>2</sup> - Standard sizes 2,5-3,5 kg/m <sup>2</sup> - Large formats 4,5-5 kg/m <sup>2</sup> <b>Color:</b> grey		<b>Granulometría:</b> max 0,5 mm <b>Herramientas:</b> espátula dentada, paleta, agitador mecánico de bajo número de revoluciones <b>Proporción de mezcla:</b> agua - 29-31% <b>Consumo:</b> Mosaicos de pequeño tamaño 2 kg/m <sup>2</sup> - estándar 2,5-3,5 kg/m <sup>2</sup> - grandes 4,5-5 kg/m <sup>2</sup> <b>Color:</b> gris	

tecniche	certificazioni	proprietà	tecnologie
 WATER BASED  TROWEL			

## glueflex ultra bianco

scheda  
tecnicadata  
sheetficha  
técnica

adesivo cementizio bianco classe C2TE	interno esterno	flexible cement- based white adhesive, class C2TE	indoor outdoor	adhesivo cementoso blanco flexible clase C2TE	interior exterior
Adesivo cementizio bianco flessibile (S1) ad alte prestazioni (C2) a scivolamento verticale nullo (T inferiore a 0,5mm). Tempo aperto allungato (E) per piastrelle in ceramica e gres porcellanato di medie dimensioni (300mm x 300 mm), materiale lapideo, cotto e Klinker. Idoneo per incollaggio di ceramica e gres anche in grande formato a pavimento standard e per pavimenti riscaldati. Per uso professionale.		High-performance (C2), flexible (S1) cement-based grey adhesive with no vertical slip (T less than 0.5 mm). Extended open time (E) for medium-sized ceramic tiles and porcelain stoneware (300 mm x 300 mm), stone, terracotta, and klinker. Suitable for gluing ceramic and stoneware tiles, even in large sizes, to standard and heated floors. For indoor and outdoor use. For professional use.		Adhesivo cementoso blanco flexible (S1) de altas prestaciones (C2) con deslizamiento vertical nulo (T inferior a 0,5 mm). Tiempo abierto prolongado (E) para baldosas en cerámica y gres porcelánico de tamaño mediano (300 mm x 300 mm), material lapideo, barro cocido y klinker. Idóneo para encolado de cerámica y gres, incluso en formatos grandes, a suelos estándares y para suelos radiantes. Para uso profesional.	
<b>Granulometria:</b> max 0,5 mm <b>Attrezzatura:</b> spatola dentata, cazzuola, impastatrice a basso numero di giri <b>Rapporto di miscelazione:</b> acqua - 30-32% <b>Consumo:</b> Mosaici piccoli formati 2 kg/m <sup>2</sup> - standard 2,5-3,5 kg/m <sup>2</sup> - grandi 4,5-5 kg/m <sup>2</sup> <b>Color:</b> bianco		<b>Particle size:</b> max 0,5 mm <b>Equipment:</b> serrated spatula, trowel, low speed mixer <b>Mixing Ratio:</b> water - 30-32% <b>Coverage:</b> Small Mosaics 2 kg/m <sup>2</sup> - Standard sizes 2,5-3,5 kg/m <sup>2</sup> - Large formats 4,5-5 kg/m <sup>2</sup> <b>Color:</b> white		<b>Granulometría:</b> max 0,5 mm <b>Herramientas:</b> espátula dentada, paleta, agitador mecánico de bajo número de revoluciones <b>Proporción de mezcla:</b> agua - 30-32% <b>Consumo:</b> Mosaicos de pequeño tamaño 2 kg/m <sup>2</sup> - estándar 2,5-3,5 kg/m <sup>2</sup> - grandes 4,5-5 kg/m <sup>2</sup> <b>Color:</b> blanco	

tecniche	certificazioni	proprietà	tecnologie
 WATER BASED  TROWEL			







**sigillan**

# prodotti

sigiltow fl

sigiltow universale

celertow

malta modellabile

# nti

## sigil tow fl

scheda  
tecnicadata  
sheetficha  
técnica

sigillante per fughe da 3 a 15 mm classe CG2	<b>interno esterno</b>	sealant for joints from 3 to 15 mm, class CG2	<b>indoor outdoor</b>	sellador para juntas de 3 a 15 mm clase CG2	<b>interior exterior</b>
Malta sigillante cementizia (C) per fughe (G) tra piastrelle migliorata (2) da 3 a 15 mm. Classe secondo norma europea EN 13888 CG2. Idoneo per stuccature di piastrelle ceramiche, gres, listelli klinker e cotto. Ideale come fugante per TermoK8 Modular D e Facciavista. Miscelato con acqua il prodotto diventa una malta di facile applicazione e pulizia. Per interni ed esterni. Per uso professionale.		Improved cement sealing mortar (C) for joints (G) between tiles (2) from 3 to 15 mm. Classification as per European standard EN 13888 CG2. Suitable for plastering ceramic and stoneware tiles, clinker slips, and terracotta slips. Ideal as a grout for TermoK8 Modular D and Facciavista. When mixed with water, the product yields a mortar that is easy to apply and clean. For professional use.		Mortero sellador de cemento (C) para juntas (G) entre baldosas mejorado (2) de 3 a 15 mm. Clase conforme a la norma europea EN 13888 CG2. Idóneo para emplastes de baldosas cerámicas, gres, listeles de clinker y barro cocido. Ideal como mortero de rejuntado para TermoK8 Modular D y Facciavista. Mezclado con agua, el producto es un mortero de fácil aplicación y limpieza. Para uso profesional.	
<b>Granulometria:</b> max 0,5 mm <b>Attrezzatura:</b> spatola, cazzuola, impastatrice a basso numero di giri <b>Rapporto di miscelazione:</b> acqua - 18-20% <b>Consumo:</b> in base alla dimensione delle piastrelle <b>Colore:</b> bianco 01, grigio cemento 30, grigio Manhattan 33, grigio silver 29, antracite 31		<b>Particle size:</b> max 0,5 mm <b>Equipment:</b> spatula, trowel, low speed mixer <b>Mixing Ratio:</b> water - 18-20% <b>Coverage:</b> according to tiles size <b>Color:</b> white 01, cement grey 30, Manhattan grey 33, silver grey 29, anthracite 31		<b>Granulometría:</b> max 0,5 mm <b>Herramientas:</b> espátula, paleta, agitador mecánico de bajo número de revoluciones <b>Proporción de mezcla:</b> agua - 18-20% <b>Consumo:</b> basado en el tamaño de las baldosas <b>Color:</b> blanco 01, gris cemento 30, gris Manhattan 33, gris silver 29, antracite 31	

tecniche	certificazioni	proprietà	tecnologie
 WATER BASED  TROWEL	 CE EN 13888 CG2		

## sigil tow universale

scheda  
tecnicadata  
sheetficha  
técnica

sigillante per fughe da 2 a 15 mm classe CG2	<b>interno esterno</b>	sealant for joints from 2 to 15 mm, class CG2	<b>indoor outdoor</b>	sellador para juntas de 2 a 15 mm clase CG2	<b>interior exterior</b>
Malta sigillante cementizia (C) per fughe (G) tra piastrelle migliorata (2) da 1 a 15 mm per fughe di pavimenti e rivestimenti ceramici di ogni tipo (monocottura, bicottura, clinker, gres porcellanato...) materiale lapideo, mosaico, vetro mattone e marmo. Miscelato con acqua il prodotto diventa una malta di facile applicazione e pulizia. Per uso professionale.		Improved (2) cement-based sealing mortar (C) for joints (G) between tiles from 1 to 15 mm for joints between all types of tile flooring and covering (single-fired, double-fired, clinker, porcelain stoneware, etc.) stone, mosaics, glass, brick, and marble. When mixed with water, the product yields a mortar that is easy to apply and clean. For professional use.		Mortero sellador de cemento (C) para juntas (G) entre baldosas mejorado (2) de 1 a 15 mm para juntas de suelos y revestimientos cerámicos de todo tipo (monococción, bicocción, clinker, gres porcelánico...) material lapideo, mosaico, ladrillos de vidrio y mármol. Mezclado con agua, el producto es un mortero de fácil aplicación y limpieza. Para uso profesional.	
<b>Granulometria:</b> max 0,3 mm <b>Attrezzatura:</b> spatola, cazzuola, impastatrice a basso numero di giri <b>Rapporto di miscelazione:</b> acqua - 25-27% <b>Consumo:</b> in base alla dimensione delle piastrelle <b>Colore:</b> bianco 01, grigio cemento 30, grigio perla 29, antracite 31		<b>Particle size:</b> max 0,3 mm <b>Equipment:</b> spatula, trowel, low speed mixer <b>Mixing Ratio:</b> water - 25-27% <b>Coverage:</b> according to tiles size <b>Color:</b> white 01, cement grey 30, pearl grey 29, anthracite 31		<b>Granulometría:</b> max 0,3 mm <b>Herramientas:</b> espátula, paleta, agitador mecánico de bajo número de revoluciones <b>Proporción de mezcla:</b> agua - 25-27% <b>Consumo:</b> basado en el tamaño de las baldosas <b>Color:</b> blanco 01, gris cemento 30, gris perla 29, antracite 31	

tecniche	certificazioni	proprietà	tecnologie
 WATER BASED  TROWEL	 CE EN 13888 CG2		



# celertow



scheda  
tecnica



data  
sheet



ficha  
técnica



legante per fissaggi a presa rapida	<b>interno esterno</b>	binder for fast-setting fixings	<b>indoor outdoor</b>	aglutinante para fijaciones de fraguado rápido	<b>interior exterior</b>
Legante antiritiro in polvere a presa rapida a base di cemento inerte ed additivi. Idoneo per ripristini di piccole superfici verticali e soffittature, rinzaffi, piccole stuccature, e fissaggio di elementi nelle murature. Per interno e esterno. Per uso professionale.		Fast setting, anti-shrinkage powder binder containing inert cement and additives. Suitable to repair small vertical walls and ceiling surfaces, rough coats, minor plastering and for securing masonry features. For professional use.		Aglutinante anti-retracción en polvo de fraguado rápido a base de cemento inerte y aditivos. Idóneo para renovación de pequeñas superficies verticales y techos, repellados, pequeños emplastes y fijación de elementos en las paredes. Para uso profesional.	
<b>Granulometria:</b> max 0,6 mm <b>Attrezzatura:</b> spatola, cazzuola, impastatrice a basso numero di giri <b>Rapporto di miscelazione:</b> acqua - 22% <b>Consumo:</b> 1,5 kg per litro di cavità <b>Colore:</b> grigio		<b>Particle size:</b> max 0,6 mm <b>Equipment:</b> spatula, trowel, low speed mixer <b>Mixing Ratio:</b> water - 22% <b>Coverage:</b> 1,5 kg per litre of cavity <b>Color:</b> grey		<b>Granulometría:</b> max 0,6 mm <b>Herramientas:</b> espátula, paleta, agitador mecánico de bajo número de revoluciones <b>Proporción de mezcla:</b> agua - 22% <b>Consumo:</b> 1,5 kg por litro de cavidad <b>Color:</b> gris	

tecniche		certificazioni		proprietà		tecnologie	

# malta modellabile



scheda  
tecnica



data  
sheet



ficha  
técnica



malta fibrata tixotropica da ricostruzione base calce	<b>interno esterno</b>	lime-based fibre-reinforced thixotropic mortar for reconstruction	<b>indoor outdoor</b>	mortero fibrado tixotrópico de reconstrucción a base de cal	<b>interior exterior</b>
Malta preconfezionata fibrata a base di Calce Idraulica Naturale, a presa rapida e basso modulo elastico. Consente la perfetta ricostruzione di cornicioni, modanature, capitelli e fregi essendo immediatamente modellabile e sagomabile. Altamente tixotropica e antiritiro. Particolarmente idonea per gli interventi di ripristino in edifici storici monumentali. Per uso professionale.		Fast setting, low elastic modulus pre-mixed fibre-reinforced mortar. Can be promptly moulded and shaped, allowing perfect reconstruction of cornices, mouldings, capitals and friezes. Highly thixotropic and anti-shrinkage. Particularly suited for repairs to historic buildings and monuments. For professional use		Mortero preenvasado fibrado de fraguado rápido y módulo elástico bajo. Permite la perfecta reconstrucción de cornisas, molduras, capiteles y frisos, ya que admite modelado y perfilado directo. Altamente tixotrópica y anti-retracción. Particularmente adecuada para las actuaciones de renovación de edificios históricos monumentales. Para uso profesional.	
<b>Granulometria:</b> max 1,2 mm <b>Attrezzatura:</b> spatola, cazzuola, impastatrice a basso numero di giri <b>Rapporto di miscelazione:</b> acqua - 22% <b>Consumo:</b> 16 kg/m <sup>2</sup> per cm di spessore <b>Colore:</b> nocciola		<b>Particle size:</b> max 1,2 mm <b>Equipment:</b> spatula, trowel, low speed mixer <b>Mixing Ratio:</b> water - 22% <b>Coverage:</b> 16 kg/m <sup>2</sup> per mm of thickness <b>Color:</b> hazelnut		<b>Granulometría:</b> max 1,2 mm <b>Herramientas:</b> espátula, paleta, agitador mecánico de bajo número de revoluciones <b>Proporción de mezcla:</b> agua - 22% <b>Consumo:</b> 16 kg/m <sup>2</sup> per cm de espesor <b>Color:</b> avellanado	

tecniche		certificazioni		proprietà		tecnologie	





# deumid

# prodotti

towsan primer

towsan

towsan light

towsan finitura

tow-rin



# ificanti

## towsan primer

scheda  
tecnicadata  
sheetficha  
técnica

impregnante antisale per murature umide	<b>interno esterno</b>	anti-salt impregnating agent for damp masonry	<b>indoor outdoor</b>	impregnante antisal para paredes húmedas	<b>interior exterior</b>
Impregnante costituito da una miscela di silicati e derivati silicologici opportunamente modificati e stabilizzati. Idoneo per il bloccaggio delle efflorescenze saline su murature umide. Da utilizzarsi previamente prima di applicare intonaco Towsan. Per uso professionale.		Impregnating agent consisting of a mixture of silicates and silicone derivatives suitably modified and stabilised. Ideal to block efflorescence and defend against capillary rising damp. To be used in advance before applying Towsan plaster. For professional use.		Impregnante constituido por una mezcla de silicatos y derivados silicólicos convenientemente modificados y estabilizados. Perfecto para bloquear las efflorescencias y contener la extensión del agua. Utilizar previamente antes de aplicar el yeso Towsan. Para uso profesional.	
<b>Attrezzatura:</b> pennello <b>Rapporto di miscelazione:</b> acqua - 100% <b>Resa:</b> 6-8 m <sup>2</sup> /l <b>Colore:</b> bianco		<b>Equipment:</b> brush <b>Mixing Ratio:</b> water - 100% <b>Coverage:</b> 6-8 m <sup>2</sup> /l <b>Color:</b> white		<b>Herramientas:</b> brocha <b>Proporción de mezcla:</b> agua - 100% <b>Rendimiento:</b> 6-8 m <sup>2</sup> /l <b>Color:</b> blanco	

tecniche	certificazioni	proprietà	tecnologie
 WATER BASED			
 BRUSH			

## towsan

scheda  
tecnicadata  
sheetficha  
técnica

intonaco deumidificante	<b>interno esterno</b>	dehumidifying plaster	<b>indoor outdoor</b>	enfoscado deshumidificante	<b>interior exterior</b>
Intonaco deumidificante per ripristini verticali idoneo al risanamento di murature umide. Premiscelato a base di cementi e sabbie selezionate industriali ed additivi specifici (aeranti, compensatore di ritiri, reazione pozzolanica per migliorare la resistenza ai solfati). Necessaria applicazione previa di Towsan Primer. Per uso professionale.		Dehumidifying plaster for vertical repairs, suited for restoring damp masonry. Premix based on selected industrial cements and sands and specific additives (aerators, shrinkage compensator, pozzolanic reaction to improve resistance to sulphates). Easy to work. The layers applied adhere well, are durable and show no shrinkage. Necessary prior application of Towsan Primer. For professional use.		Enfoscado deshumidificante para renovaciones verticales, adecuado para saneamiento de paredes con humedad. Premezclado a base de cementos y arenas seleccionadas industriales y aditivos específicos (aireantes, compensador de retracción, reacción pozzolánica para mejorar la resistencia a los sulfatos). Aplicación previa necesaria de Towsan Primer. Para uso profesional.	
<b>Granulometria:</b> max 1,2 mm <b>Attrezzatura:</b> spatola, cazzuola, betoniera <b>Rapporto di miscelazione:</b> acqua - 20% <b>Consumo:</b> 28 kg/m <sup>2</sup> per 2 cm di spessore <b>Colore:</b> grigio		<b>Particle size:</b> max 1,2 mm <b>Equipment:</b> spatula, trowel, cement mixer <b>Mixing Ratio:</b> water - 20% <b>Coverage:</b> 28 kg/m <sup>2</sup> per 2 mm of thickness <b>Color:</b> grey		<b>Granulometría:</b> max 1,2 mm <b>Herramientas:</b> espátula, paleta, hormigonera <b>Proporción de mezcla:</b> agua - 20% <b>Consumo:</b> 28 kg/m <sup>2</sup> per 2 cm de espesor <b>Color:</b> gris	

tecniche	certificazioni	proprietà	tecnologie
 WATER BASED	 EN 998-1 RCS II		
 TROWEL			

## towsan light

scheda  
tecnicadata  
sheetficha  
técnica

intonaco deumidificante alleggerito	<b>interno esterno</b>	lightweight dehumidifying plaster	<b>indoor outdoor</b>	enfoscado deshumidificante aligerado	<b>interior exterior</b>
Malta da intonaco deumidificante alleggerita per ripristini verticali idoneo al risanamento di murature umide. Premiscelato a base di cementi inerti leggeri, sabbie selezionate industriali ed additivi specifici. Intonaco perfettamente lavorabile i cui strati applicati risultano ben aderenti, durevoli e privi di ritiro. Non necessita di primer antisale. Per uso professionale.		Dehumidifying lightweight mortar to repair vertical walls. Suitable for restoring damp masonry. Premix based on light inert cements, selected industrial sands and specific additives. No need for an anti-salt primer. The layers applied adhere well, are durable and show no shrinkage. For professional use.		Mortero deshumidificante aligerado para renovaciones verticales, idóneo para el saneamiento de paredes con humedad. Premezclado a base de cementos áridos ligeros y arenas seleccionadas industriales y aditivos específicos. Enfoscado perfectamente elaborable cuyas capas aplicadas ofrecen un resultado bien adherente, duradero y sin retracción. Sin necesidad de imprimación anti-sal. Para uso profesional.	
<b>Granulometria:</b> max 1,2 mm <b>Attrezzatura:</b> spatola, cazzuola, betoniera <b>Rapporto di miscelazione:</b> acqua - 18% <b>Consumo:</b> 20 kg/m <sup>2</sup> per 2 cm di spessore <b>Colore:</b> grigio		<b>Particle size:</b> max 1,2 mm <b>Equipment:</b> spatula, trowel, cement mixer <b>Mixing Ratio:</b> water - 18% <b>Coverage:</b> 20 kg/m <sup>2</sup> per 2 mm of thickness <b>Color:</b> grey		<b>Granulometría:</b> max 1,2 mm <b>Herramientas:</b> espátula, paleta, hormigonera <b>Proporción de mezcla:</b> agua - 18% <b>Consumo:</b> 20 kg/m <sup>2</sup> per 2 cm de espesor <b>Color:</b> gris	

tecniche	certificazioni	proprietà	tecnologie
 WATER BASED	 EN 998-1 RCS II		
 TROWEL			

## towsan finitura

scheda  
tecnicadata  
sheetficha  
técnica

rasante minerale bianco traspirante - 0,4 mm	<b>interno esterno</b>	breathable white mineral skim coat - 0.4 mm	<b>indoor outdoor</b>	mortero de enrasado mineral blanco transpirante- 0,4 mm	<b>interior exterior</b>
Rasante minerale bianco grana 0,4. L'ottima traspirabilità lo rende idoneo per la rasatura a civile fine di Towsan e Towsan Light. A base di inerti selezionati, leganti aerei, idraulici ed additivi specifici. Dotato di ottima spatolabilità e riempimento, estremamente versatile per la facilità d'uso. Per uso professionale.		White mineral skim coat, with 0.4mm grain size. Its excellent breathability makes it suitable for fine two-coat skimming of Towsan and Towsan Light. Based on selected inert materials, hydraulic and air binders, and specific additives. With superb spreadability and filling capacity, it is extremely versatile due to its ease of use. For professional use.		Mortero de enrasado mineral blanco grano 0,4. La excelente transpirabilidad lo hace idóneo para el enrasado de revoco fino de Towsan y Towsan Light. A base de áridos seleccionados, aglutinantes aéreos e hidráulicos y aditivos específicos. Excelente facilidad para su extensión con espátula y relleno, extremadamente versátil por su facilidad de uso. Para uso profesional.	
<b>Granulometria:</b> max 0,4 mm <b>Attrezzatura:</b> spatola, cazzuola, frattazzo, impastatrice a basso numero di giri <b>Rapporto di miscelazione:</b> acqua - 20-22% <b>Consumo:</b> 1,4 kg/m <sup>2</sup> per mm di spessore <b>Colore:</b> bianco		<b>Particle size:</b> max 0,4 mm <b>Equipment:</b> spatula, trowel, trowel, low speed mixer <b>Mixing Ratio:</b> water - 20-22% <b>Coverage:</b> 1,4 kg/m <sup>2</sup> per mm of thickness <b>Color:</b> white		<b>Granulometría:</b> max 0,4 mm <b>Herramientas:</b> espátula, paleta, frattazzo, agitador mecánico de bajo número de revoluciones <b>Proporción de mezcla:</b> agua - 20-22% <b>Consumo:</b> 1,4 kg/m <sup>2</sup> per mm de espesor <b>Color:</b> blanco	

tecniche	certificazioni	proprietà	tecnologie
 WATER BASED  TROWEL			

## tow-rin

scheda  
tecnicadata  
sheetficha  
técnica

intonaco minerale da ripristino e rinzaffo - 3 mm	<b>interno esterno</b>	mineral plaster for repairs and rough coats - 3 mm	<b>indoor outdoor</b>	mortero de enfoscado mineral de renovación y repellido - 3 mm	<b>interior exterior</b>
Malta da intonaco per ripristino di Intonaci esistenti fino a 30 mm e rinzaffo minerale per le riprese localizzate. Composto premiscelato costituito da leganti idraulici, inerti selezionati, additivi specifici e fibre. Tow-Rin è una malta additivata per promuovere l'adesione di intonaci calce - cemento su vecchie murature non omogenee. Idoneo per applicazione meccanica e manuale. Per uso professionale.		Plaster mortar for repairing existing plaster up to 30 mm and mineral rough coats for localised repairs. This product is a premix composed of hydraulic binders, selected inert materials, specific additives, and fibres. Tow-Rin contains additives that improve adhesion of lime- and cement-based plaster on old, uneven walls. Suitable for mechanical and manual application. For professional use.		Mortero de enfoscado para renovación de enfoscados ya existentes de hasta 30 mm y repellido mineral para puntos localizados. Compuesto premezclado constituido por aglutinantes hidráulicos, áridos seleccionados, aditivos específicos y fibras. Tow-Rin es un mortero con aditivos para activar la adhesión de enfoscados de cal - cemento sobre paredes viejas no homogéneas. Idóneo para aplicación mecánica y manual. Para uso profesional.	
<b>Granulometria:</b> max 3 mm <b>Attrezzatura:</b> spatola, cazzuola, intonacatrice meccanica <b>Rapporto di miscelazione:</b> acqua - 20-22% <b>Consumo:</b> 15 kg/m <sup>2</sup> per cm di spessore <b>Colore:</b> grigio		<b>Particle size:</b> max 3 mm <b>Equipment:</b> spatula, trowel, mechanical plastering machine <b>Mixing Ratio:</b> water - 20-22% <b>Coverage:</b> 15 kg/m <sup>2</sup> per mm of thickness <b>Color:</b> grey		<b>Granulometría:</b> max 3 mm <b>Herramientas:</b> espátula, paleta, enfoscadora mecánica <b>Proporción de mezcla:</b> agua - 20-22% <b>Consumo:</b> 15 kg/m <sup>2</sup> per cm de espesor <b>Color:</b> gris	

tecniche	certificazioni	proprietà	tecnologie
 WATER BASED  TROWEL  PLASTERING MACHINE			





**massetti**



tow level



scheda  
tecnica



data  
sheet



ficha  
técnica



autolivellante cementizio spessore massimo 3-10 mm	<b>interno esterno</b>	cement-based, self-levelling, max thickness 3-10 mm	<b>indoor outdoor</b>	autonivelante de cemento de espesor máximo 3-10 mm	<b>interior exterior</b>
<p>Malta autolivellante per pavimenti ad asciugatura rapida. Idonea per livellare ed eliminare differenze di spessore da 3 a 10 mm di sottofondi nuovi o preesistenti creando un piano perfettamente planare e uniforme adatto a ricevere ogni tipo di pavimento. Dotato di elevate resistenze meccaniche e ottimo potere di adesione, offre un'ottima resistenza al traffico e al carico. Per uso professionale.</p>		<p>Self-levelling and quick-drying mortar for indoor floors. Suitable for levelling and getting rid of thickness differences from 3 to 10 mm of new or existing substrates, it creates a perfectly level and uniform surface for receiving all types of flooring. As it has high mechanical resistance and an outstanding adhesion power, it offers excellent traffic and load resistance. For professional use.</p>		<p>Mortero autonivelante para suelos, de secado rápido. Idóneo para nivelar y eliminar diferencias de espesor de 3 a 10 mm de sustratos nuevos o preexistentes, creando una superficie perfectamente plana y uniforme, adecuada para recibir todo tipo de suelos. Dotado de altas resistencias mecánicas y excelente poder adhesivo, ofrece una excelente resistencia al tráfico y a la carga. Para uso profesional.</p>	
<p><b>Granulometria:</b> max 0,6 mm <b>Attrezzatura:</b> impastatrice a basso numero di giri, spatola, racla di gomma, rullo frangibolle <b>Rapporto di miscelazione:</b> acqua - 24-25% <b>Consumo:</b> 1,6 kg/m<sup>2</sup> per cm di spessore <b>Colore:</b> grigio</p>		<p><b>Particle size:</b> max 0,6 mm <b>Equipment:</b> low speed mixer, spatula, rubber squeegee, bubble-buster roller <b>Mixing Ratio:</b> water - 24-25% <b>Coverage:</b> 1,6 kg/m<sup>2</sup> per mm of thickness <b>Color:</b> grey</p>		<p><b>Granulometría:</b> max 0,6 mm <b>Herramientas:</b> agitador mecánico de bajo número de revoluciones, espátula, rasqueta de goma, rodillo antiburbujas <b>Proporción de mezcla:</b> agua - 24-25% <b>Consumo:</b> 1,6 kg/m<sup>2</sup> per cm de espesor <b>Color:</b> gris</p>	

tecniche			certificazioni	proprietà				tecnologie			



**impermea**

# prodotti

towflex

towflex ap

monoflex

towseal

towpruf



# stabilizzanti

## towflex

scheda  
tecnicadata  
sheetficha  
técnica

rasante impermeabilizzante elastico bicomponente	interno esterno	two-pack elastic waterproofing skim coat	indoor outdoor	mortero de enrasado impermeabilizante elástico bicomponente	interior exterior
Malta cementizia bicomponente elastica per l'impermeabilizzazione in spinta positiva di superfici in calcestruzzo, balconi, terrazze, bagni e piscine. Composta da un miscela di aggregati silicei, cemento, fibre parte A e da emulsione di resine elastiche parte B. La miscela dei componenti è stata studiata per avere una perfetta lavorabilità ed un'altissima adesione ai vari supporti. Spessore massimo applicabile 3 mm in due mani con opzione di rete di armatura Armatex C1. Per uso professionale.		Two-pack elastic cement-based mortar to waterproof and protect concrete surfaces, balconies, terraces, baths and swimming pools. Towflex is a mixture of silica aggregates, cement and fibres in part A and an emulsion of elastic resins in part B. This formula has been designed to ensure perfect workability and excellent adhesion to various substrates. Maximum applicable thickness 3 mm in two coats with Armatex C1 reinforcement mesh option. For professional use.		Mortero de cemento bicomponente elástico para la impermeabilización y protección de superficies de hormigón, balcones, terrazas, baños y piscinas. Towflex está formado por una mezcla de agregados silíceos, cemento y fibras (parte A) y emulsión de resinas elásticas (parte B). La mezcla de los componentes ha sido estudiada para que permita una perfecta facilidad de elaboración y un altísimo grado de adhesión a los distintos soportes. Espesor máximo aplicable 3 mm en dos manos con opción de malla de refuerzo Armatex C1. Para uso profesional.	
<b>Granulometria:</b> max 0,5 mm <b>Attrezzatura:</b> spatola dentata, impastatrice a basso numero di giri <b>Rapporto di miscelazione:</b> acqua - 33% <b>Consumo:</b> 1,8 kg/m <sup>2</sup> per mm di spessore <b>Colore:</b> grigio		<b>Particle size:</b> max 0,5 mm <b>Equipment:</b> serrated spatula, low speed mixer <b>Mixing Ratio:</b> water - 33% <b>Coverage:</b> 1,8 kg/m <sup>2</sup> per mm of thickness <b>Color:</b> grey		<b>Granulometría:</b> max 0,5 mm <b>Herramientas:</b> espátula dentada, agitador mecánico de bajo número de revoluciones <b>Proporción de mezcla:</b> agua - 33% <b>Consumo:</b> 1,8 kg/m <sup>2</sup> per mm de espesor <b>Color:</b> gris	

tecniche	certificazioni	proprietà	tecnologie
 WATER BASED  TROWEL	 EN 1504-2 PI-MC-IR		

## towflex ap

scheda  
tecnicadata  
sheetficha  
técnica

rasante impermeabilizzante per contatto con acqua potabile	interno esterno	waterproofing skim coat for contact with drinking water	indoor outdoor	mortero de enrasado impermeabilizante para contacto con agua potable	interior exterior
Malta cementizia rasante impermeabilizzante elastico bicomponente per contatto con acqua potabile. Idoneo per l'impermeabilizzazione di vasche per il contenimento di acque ad uso potabile secondo il DM 21/03/1973 e successive modifiche come da certificato n° 141921 dell'Istituto Giordano. Può essere inoltre usato per impermeabilizzare sottofondi prima della posa della pavimentazione. Per uso professionale.		Two-pack, elastic waterproofing cement-based skimming mortar for contact with drinking water. Suitable for waterproofing tanks used to hold drinking water in compliance with Italian Ministerial Decree dated 21/03/1973 and subsequent amendments thereto as per certificate no. 141921 issued by Istituto Giordano. It can also be used to waterproof floor substrates before paving. For professional use.		Mortero de cemento para enrasado impermeabilizante elástico bicomponente para contacto con agua potable. Idóneo para la impermeabilización de estanques contenedores de agua potable según el DM 21/03/1973 y posteriores modificaciones, conforme al certificado n.º 141921 del Instituto Giordano. Puede usarse también para impermeabilizar sustratos antes de la colocación del piso. Para uso profesional.	
<b>Granulometria:</b> max 0,5 mm <b>Attrezzatura:</b> spatola dentata, impastatrice a basso numero di giri <b>Rapporto di miscelazione:</b> Il componente A va miscelato solo con il componente B; 9 litri di componente B con 25 kg di componente A <b>Consumo:</b> 1,75 kg/m <sup>2</sup> per mm di spessore <b>Colore:</b> grigio		<b>Particle size:</b> max 0,5 mm <b>Equipment:</b> serrated spatula, low speed mixer <b>Mixing Ratio:</b> Pack A should only be mixed with pack B; 9 litres of pack B with 25 kg of pack A <b>Coverage:</b> 1,75 kg/m <sup>2</sup> per mm of thickness <b>Color:</b> grey		<b>Granulometría:</b> max 0,5 mm <b>Herramientas:</b> espátula dentada, agitador mecánico de bajo número de revoluciones <b>Proporción de mezcla:</b> el componente A debe mezclarse solo con el componente B; 9 litri de componente B con 25 kg de componente A <b>Consumo:</b> 1,75 kg/m <sup>2</sup> per mm de espesor <b>Color:</b> gris	

tecniche	certificazioni	proprietà	tecnologie
 WATER BASED  TROWEL	 EN 1504-2 PI-MC-IR		

monoflex



scheda  
tecnica



data  
sheet



ficha  
técnica



malta cementizia monocomponente elastica	<b>interno esterno</b>	one-pack, elastic cement-based mortar.	<b>indoor outdoor</b>	mortero de cemento monocomponente elástico	<b>interior exterior</b>
Malta cementizia monocomponente elastica impermeabilizzante a spinta positiva. Consente di risolvere il problema dei supporti fessurati in maniera definitiva, idoneo per l'impermeabilizzazione di vasche per il contenimento di acque o sottofondi sia esterni che interni, prima della posa della pavimentazione. Ideale per la protezione del cemento armato da CO <sub>2</sub> , SO <sub>2</sub> , cloruri e solfati. Applicabile in bassi spessori anche a pennello. Per uso professionale.		One-pack, elastic, positive-thrust waterproofing, cement-based mortar. This product permanently addresses surface cracks, and is suitable for waterproofing water holding tanks or substrates, both indoors and outdoors, before paving. Ideal for protecting reinforced concrete from CO <sub>2</sub> , SO <sub>2</sub> , chlorides, and sulphates. Can be applied in thin coats, even with a brush. For professional use.		Mortero de cemento monocomponente elástico impermeabilizante de empuje positivo. Permite resolver el problema de los soportes con fisuras de forma definitiva, idóneo para la impermeabilización de estanques para la contención de agua o para sustratos tanto externos como internos, antes de la colocación del suelo. Ideal para la protección del hormigón armado contra CO <sub>2</sub> , SO <sub>2</sub> , cloruros y sulfatos. Aplicable en espesores bajos también con brocha. Para uso profesional.	
<b>Granulometria:</b> max 0,5 mm <b>Attrezzatura:</b> spatola, cazzuola, impastatrice a basso numero di giri <b>Rapporto di miscelazione:</b> acqua - 24% <b>Consumo:</b> 1,2 kg/m <sup>2</sup> per mm di spessore <b>Colore:</b> grigio		<b>Particle size:</b> max 0,5 mm <b>Equipment:</b> spatula, trowel, low speed mixer <b>Mixing Ratio:</b> water - 24% <b>Coverage:</b> 1,2 kg/m <sup>2</sup> per mm of thickness <b>Color:</b> grey		<b>Granulometría:</b> max 0,5 mm <b>Herramientas:</b> espátula, paleta, agitador mecánico de bajo número de revoluciones <b>Proporción de mezcla:</b> agua - 24% <b>Consumo:</b> 1,2 kg/m <sup>2</sup> per mm de espesor <b>Color:</b> gris	

tecniche		certificazioni		proprietà				tecnologie	

towerseal



scheda  
tecnica



data  
sheet



ficha  
técnica



boiaccia impermeabilizzante osmotica a basso spessore	<b>interno esterno</b>	low thickness osmotic waterproofing groutsore	<b>indoor outdoor</b>	lechada impermeabilizante osmótica de bajo espesor	<b>interior exterior</b>
Impermeabilizzante osmotico a base di cementi, inerti selezionati e additivi specifici, per il contenimento delle acque sia in spinta positiva che negativa. Idoneo per impermeabilizzare a basso spessore supporti in CLS quali vani ascensore, piscine e cantine. Applicazione prima mano a spatola in acciaio liscia e mani successive incrociate a pennello. Per uso professionale.		Osmotic waterproofing product based on cements, selected inert materials and specific additives, for water containment in the case of both positive and negative thrust. Suitable for waterproofing low-thickness concrete substrates such as lift shafts, swimming pools, and cellars. First coat applied with a smooth steel spatula and subsequent cross coats by brush. For professional use.		Impermeabilizante osmótico a base de cementos, áridos seleccionados y aditivos específicos, para contención de aguas tanto de empuje positivo como negativo. Idóneo para impermeabilizar con espesores bajos soportes de hormigón como huecos de ascensor, piscinas y sótanos. Aplicación de primera mano con espátula en acero lisa y manos sucesivas en pasadas de brocha cruzadas. Para uso profesional.	
<b>Granulometria:</b> max 0,4 mm <b>Attrezzatura:</b> spatola, cazzuola, intonacatrice meccanica <b>Rapporto di miscelazione:</b> acqua - 24-26% <b>Consumo:</b> 1,7 kg/m <sup>2</sup> per mm di spessore <b>Colore:</b> grigio		<b>Particle size:</b> max 0,4 mm <b>Equipment:</b> spatula, trowel, mechanical plastering machine <b>Mixing Ratio:</b> water - 24-26% <b>Coverage:</b> 1,7 kg/m <sup>2</sup> per mm of thickness <b>Color:</b> grey		<b>Granulometría:</b> max 0,4 mm <b>Herramientas:</b> espátula, paleta, enfoscadora mecánica <b>Proporción de mezcla:</b> agua - 24-26% <b>Consumo:</b> 1,7 kg/m <sup>2</sup> per mm de espesor <b>Color:</b> gris	

tecniche		certificazioni		proprietà				tecnologie	



## towpruf

scheda  
tecnicadata  
sheetficha  
técnica

intonaco impermeabilizzante osmotico	interno esterno	osmotic waterproofing plaster	indoor outdoor	mortero de enfoscado impermeabilizante osmótico	interior exterior
Malta da intonaco osmotica antiritiro a granulometria massima di 1,2 mm, idonea per impermeabilizzazione in verticale sia in spinta positiva che negativa di locali interrati, box, fosse d'ascensore e strutture atte al contenimento di acque, quali condotte, canalizzazioni, piscine e serbatoi. Miscela cementizia pronta all'uso, perfettamente lavorabile, ad altissima adesione su strutture in calcestruzzo. Applicabile a mano o con macchine bi-stadio (no intonacatrici in continuo). Per uso professionale.		Anti-shrinkage osmotic plaster mortar with maximum particle size of 1.2 mm, suitable for vertical waterproofing – for both positive and negative thrust – of underground rooms, garages, lift shafts, and structures designed to contain water, such as pipelines, ducts, swimming pools and tanks. Ready-to-use, perfectly workable cement-based mixture with very high adhesion on concrete structures. Can be applied by hand or with two-stage machines (not continuous plastering machines). For professional use.		Mortero de enfoscado osmótico anti-retracción con granulometría máxima de 1,2 mm, idóneo para impermeabilizar en vertical tanto en empuje positivo como negativo locales subterráneos, trasteros, huecos de ascensor y estructuras para la contención de aguas, como conductos, canalizaciones, piscinas y depósitos. Mezcla de cemento lista para usar, perfectamente elaborable, de altísimo poder adhesivo sobre estructuras de hormigón. Aplicable a mano o con máquinas de dos etapas (no enfoscadoras continuas). Para uso profesional.	
<b>Granulometria:</b> max 1,2 mm <b>Attrezzatura:</b> spatola, cazzuola, frattazzo di spugna, impastatrice a basso numero di giri <b>Rapporto di miscelazione:</b> acqua - 18% <b>Consumo:</b> 16 kg/m <sup>2</sup> per cm di spessore <b>Colore:</b> grigio		<b>Particle size:</b> max 1,2 mm <b>Equipment:</b> spatula, trowel, mason's trowel, low speed mixer <b>Mixing Ratio:</b> water - 18% <b>Coverage:</b> 16 kg/m <sup>2</sup> per mm of thickness <b>Color:</b> grey		<b>Granulometría:</b> max 1,2 mm <b>Herramientas:</b> espátula, paleta, frattazzo di spugna, agitador mecánico de bajo número de revoluciones <b>Proporción de mezcla:</b> agua - 18% <b>Consumo:</b> 16 kg/m <sup>2</sup> per cm de espesor <b>Color:</b> gris	

tecniche		certificazioni	proprietà				tecnologie			
										





# additivi e leganti

resintow



scheda  
tecnica



data  
sheet



ficha  
técnica



additivo liquido elasticizzante per malte	interno esterno	elasticising liquid additive for mortars.	indoor outdoor	aditivo líquido elastizante para morteros	interior exterior
<p>Additivo liquido per migliorare l'elasticità e l'adesione di malte e miscele cementizie. Adesivante liquido a base di resine elastomeriche fortemente resistenti agli alcali e non riemulsionabili in acqua. Tale emulsione forma un film che lega il cemento e la sabbia ed aumenta l'elasticità della malta incrementandone l'aderenza ai supporti e la resistenza meccanica all'usura. Per uso professionale.</p>		<p>Liquid additive to improve adhesion of cement mortars and mixtures. Liquid adhesive containing elastomeric resins, which are highly resistant to alkalis and cannot be re-emulsified in water. This emulsion forms a film that binds cement and sand and increases the elasticity of the mortar, increasing adherence to the substrate and mechanical resistance to wear. For professional use.</p>		<p>Aditivo líquido para mejorar la adhesión de morteros y mezclas de cemento. Adesivo líquido a base de resinas elastoméricas muy resistentes a los álcalis y no reemulsionables en agua. Dicha emulsión forma una película que une el cemento y la arena y aumenta la elasticidad del mortero, aumentando su adherencia a los soportes y la resistencia mecánica al desgaste. Para uso profesional.</p>	
<p><b>Attrezzatura:</b> betoniera, impastatrice a basso numero di giri <b>Diluizione:</b> acqua - 400% <b>Resa:</b> vedi scheda prodotto in cui è stato additivato <b>Colore:</b> bianco</p>		<p><b>Equipment:</b> cement mixer, low speed mixer <b>Dilution:</b> water - 400% <b>Coverage:</b> See the data sheet for the product it has been added to <b>Color:</b> white</p>		<p><b>Herramientas:</b> hormigonera, agitador mecánico de bajo número de revoluciones <b>Dilución:</b> agua - 400% <b>Rendimiento:</b> vedi scheda prodotto in cui è stato additivato <b>Color:</b> blanco</p>	

primer ra



scheda  
tecnica



data  
sheet



ficha  
técnica



promotore di adesione su superfici non assorbenti	interno esterno	adhesion promoter on poorly absorbent substrates	indoor outdoor	promotor de adhesión sobre fondos poco absorbentes	interior exterior
<p>Primer quarzifero di colore giallo semitrasparente idoneo come promotore di adesione ad effetto ruvido. A base di resine acriliche in emulsione ed inerti silicei e farine di quarzo. Appositamente studiato per favorire l'adesione di intonaci o rasanti cementizi su fondi lisci o poco assorbenti. Per uso professionale.</p>		<p>Semi-transparent yellow adhesion promoter primer with a rough effect. It contains acrylic resins in emulsion and silica inert materials of such particle size as to produce a rough surface. Specially designed to facilitate adhesion of plaster or cement-based skim coats on smooth or poorly absorbent substrates. For professional use.</p>		<p>Imprimación activadora de adhesión amarilla semitrasparente de efecto rugoso. A base de resinas acrílicas en emulsión y áridos silíceos, de granulometría adecuada para obtener una superficie rugosa. Expresamente estudiado para favorecer la adhesión de enfoscados o morteros de enrasado sobre fondos lisos o poco absorbentes. Para uso profesional.</p>	
<p><b>Attrezzatura:</b> pennello, rullo a pelo corto <b>Diluizione:</b> acqua - 50% <b>Resa (1 mano):</b> 5-6 m<sup>2</sup>/l - Per confezione (14 l): 84 m<sup>2</sup> <b>Colore:</b> giallo</p>		<p><b>Equipment:</b> brush, roller <b>Dilution:</b> water - 50% <b>Coverage (1 coat):</b> 5-6 m<sup>2</sup>/l - Per package (14 l): 84 m<sup>2</sup> <b>Color:</b> yellow</p>		<p><b>Herramientas:</b> brocha, rodillo a pelo corto <b>Dilución:</b> agua - 50% <b>Rendimiento (1 capa):</b> 5-6 m<sup>2</sup>/l - Per envase (14 l): 84 m<sup>2</sup> <b>Color:</b> amarillo</p>	

primer tack



scheda  
tecnica



data  
sheet



ficha  
técnica



promotore di adesione su superfici smaltate e legno	interno esterno	adhesion promoter on enamelled surfaces and wood	indoor outdoor	promotor de adhesión sobre superficies esmaltadas y de madera	interior exterior
<p>Primer gelatinoso monocomponente di colore azzurro semitrasparente atto ad aumentare l'adesione su sottofondi smaltati e pannelli in legn. A base di copolimeri acrilici in dispersione acquosa a bassa TMF (temperatura minima di filmazione). Per uso professionale.</p>		<p>Light blue, semi-transparent, one-pack gelatinous primer designed to increase adhesion on enamelled substrates and wood panels. Based on acrylic copolymers in an aqueous dispersion with low MFFT (minimum film forming temperature). For professional use.</p>		<p>Imprimación gelatinosa monocomponente de color celeste semitrasparente idónea para aumentar la adhesión sobre substratos esmaltados y paneles de madera. A base de copolímeros acrílicos en dispersión acuosa de baja TMF (temperatura mínima de formación de película). Para uso profesional.</p>	
<p><b>Attrezzatura:</b> rullo di spugna <b>Diluizione:</b> pronto uso <b>Resa (1 mano):</b> 150-200 g/m<sup>2</sup> - Per confezione (5 kg): 33 m<sup>2</sup> <b>Colore:</b> azzurro</p>		<p><b>Equipment:</b> sponge roller <b>Dilution:</b> ready to use <b>Coverage (1 coat):</b> 150-200 g/m<sup>2</sup> - Per package (5 kg): 33 m<sup>2</sup> <b>Color:</b> light blue</p>		<p><b>Herramientas:</b> rodillo de spugna <b>Dilución:</b> listo para usar <b>Rendimiento (1 capa):</b> 150-200 g/m<sup>2</sup> - Por envase (5 kg): 33 m<sup>2</sup> <b>Color:</b> azul</p>	





**complementi**



## angolare esterno



Complemento in tessuto poliestere gommato per l'impermeabilizzazione di giunti e spigoli e/o zone di raccordo tra il piano orizzontale e verticale.

**Dimensione:** 14 cm  
**Angolo:** 270°

Rubberised polyester fabric articles for waterproofing corner joints and/or joints between vertical and horizontal planes.

**Dimension:** 14 cm  
**Angle:** 270°

Complementos en tejido de poliéster engomado para impermeabilizar juntas de esquina y / o áreas de conexión entre el plano vertical y horizontal

**Dimensión:** 14 cm  
**Angolo:** 270°

## angolare interno



Complemento in tessuto poliestere gommato per l'impermeabilizzazione di giunti e spigoli e/o zone di raccordo tra il piano orizzontale e verticale.

**Dimensione:** 14 cm  
**Angolo:** 90°

Rubberised polyester fabric articles for waterproofing corners and/or joints between vertical and horizontal planes.

**Dimension:** 14 cm  
**Angle:** 90°

Complementos en tejido de poliéster engomado para impermeabilizar juntas de esquina y / o áreas de conexión entre el plano vertical y horizontal

**Dimensión:** 14 cm  
**Angolo:** 90°

## banda



Complemento in tessuto poliestere gommato per l'impermeabilizzazione di giunti e spigoli e/o zone di raccordo tra il piano orizzontale e verticale.

**Dimensione:** 12 x 50 cm

Rubberised polyester fabric articles for waterproofing expansion joints and gaps between vertical and horizontal planes.

**Dimension:** 12 x 50 cm

Complementos en tejido de poliéster engomado para impermeabilizar juntas de dilatación y / o zonas de conexión entre el plano vertical y horizontal para orificios pasantes

**Dimensión:** 12 x 50 cm

## guarnizione piccola



Complemento in tessuto poliestere gommato per l'impermeabilizzazione di giunti e spigoli e/o zone di raccordo tra il piano verticale e orizzontale per fori passanti

**Dimensione:** 12 x 12 cm

Rubberised polyester fabric articles for waterproofing expansion joints and gaps between vertical and horizontal planes for bore holes.

**Dimension:** 12 x 12 cm

Complementos en tejido de poliéster engomado para impermeabilizar juntas de dilatación y / o zonas de unión entre el plano vertical y horizontal para orificios pasantes

**Dimensión:** 12 x 12 cm

## guarnizione grande



Complemento in tessuto poliestere gommato per l'impermeabilizzazione di giunti e spigoli e/o zone di raccordo tra il piano verticale e orizzontale per fori passanti

**Dimensione:** 42,5 x 42,5 cm

Rubberised polyester fabric articles for waterproofing expansion joints and gaps between vertical and horizontal planes for bore holes.

**Dimension:** 42,5 x 42,5 cm

Complementos en tejido de poliéster engomado para impermeabilizar juntas de dilatación y / o zonas de unión entre el plano vertical y horizontal para orificios pasantes

**Dimensión:** 42,5 x 42,5 cm

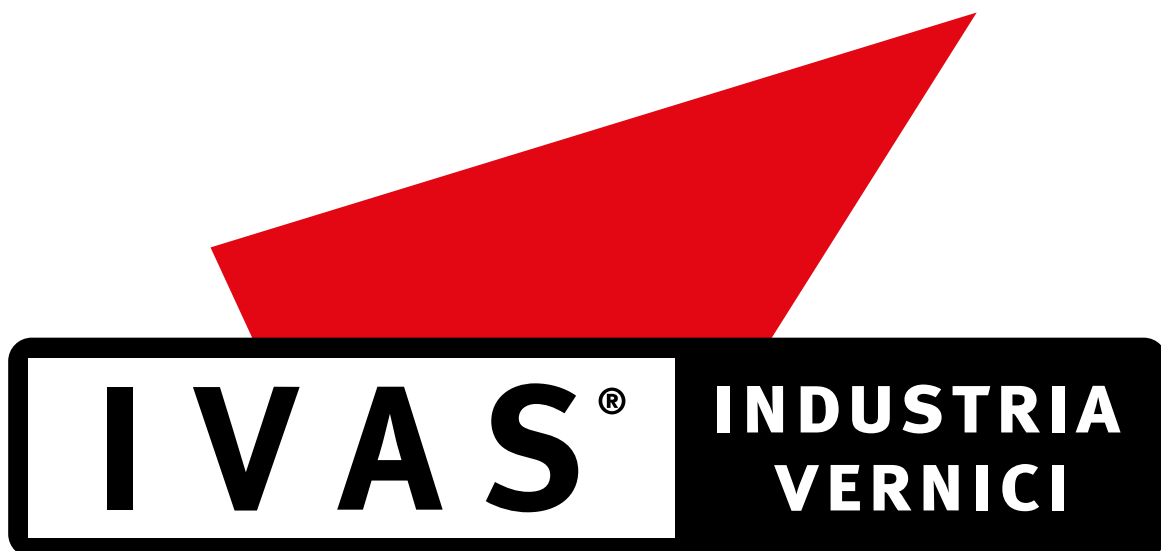

**IVAS**®

**INDUSTRIA  
VERNICI**

---

**DIVISIONE  
PAVIMENTI IN RESINA**

PAVI  
MEN  
TIIN  
RE  
SINA



# resin fl

pavimentazioni industriali e civili

# linee prodotti

impregnanti / antipolvere

promotori d'adesione

leganti per malte spatolate

rivestimenti a film sottile / spesso

rivestimenti murali

autolivellanti

protettivi e impermeabilizzanti

riempitivi minerali

poliurea

accessori

# loors



## epoxy primer wb

scheda  
tecnicadata  
sheetficha  
técnica

impregnante epossidico all'acqua	interno esterno	water-based epoxy impregnating agent	indoor outdoor	impregnante epoxidico al agua	interior exterior
<p>Formulato bicomponente a base di resina epossidica in emulsione acquosa, dotato di buona resistenza chimica, meccanica, all'acqua e all'abrasione. Se diluito con acqua, secondo le indicazioni, può essere utilizzato come impregnante rendendo il supporto antipolvere e facilmente pulibile. Il rivestimento può dare effetti di chiaro-scuro dovuti al diverso assorbimento del supporto. Primer per Aquapox. Per uso professionale.</p>		<p>Two-pack epoxy resin-based formulation in aqueous emulsion, with good chemical, mechanical, water and abrasion resistance. When diluted with water, following the indications given below, it can be used as an impregnating agent, making the substrate dustproof and easy to clean. The coating can give chiaroscuro effects due to the different substrate absorption. Primer for Aquapox. For professional use.</p>		<p>Formulación bicomponente con base de resina epoxidica en emulsión acuosa, dotada de buena resistencia química, mecánica, al agua y a la abrasión. Si se diluye con agua, según las indicaciones que se dan seguidamente, puede utilizarse como impregnante haciendo que el soporte sea antipolvo y muy fácil de limpiar. El revestimiento puede dar efectos de claro-oscuro, debido a la distinta absorción del soporte. Imprimación para Aquapox. Para uso profesional.</p>	
<p><b>Attrezzatura:</b> pennello, rullo, airless <b>Rapporto di catalisi:</b> (A:B) 1:1 <b>Diluizione:</b> acqua - come primer: 30% come impregnante antipolvere: 200% <b>Resa</b> (1 mano): come primer 100-150 g/m<sup>2</sup> - Per confezione (8+8 kg): 208 m<sup>2</sup>; come impregnante antipolvere 50-100 g/m<sup>2</sup> - Per confezione (8+8 kg): 960 m<sup>2</sup> <b>Colore:</b> incolore</p>		<p><b>Equipment:</b> brush, roller, airless <b>Mixing ration:</b> (A:B) 1:1 <b>Dilution:</b> water - as primer: 30% impregnating agent: 200% <b>Coverage</b> (1 coat): as primer 100-150 g/m<sup>2</sup> - Per package (8+8 kg): 208 m<sup>2</sup>; impregnating agent 50-100 g/m<sup>2</sup> - Per package (8+8 kg): 960 m<sup>2</sup> <b>Color:</b> transparent</p>		<p><b>Herramientas:</b> brocha, rodillo, pistola pulverizadora <b>Relación de catalisis:</b> (A:B) 1:1 <b>Dilución:</b> agua - Como imprimación: 30 % como impregnante antipolvo: 200% <b>Rendimiento</b> (1 capa): Como imprimación 100-150 g/m<sup>2</sup> - Por envase (8+8 kg): 208 m<sup>2</sup>; como impregnante antipolvo 50-100 g/m<sup>2</sup> - Por envase (8+8 kg): 960 m<sup>2</sup> <b>Color:</b> incoloro</p>	

tecniche	certificazioni	proprietà	tecnologie
 WATER BASED  BRUSH  ROLLER  AIRLESS			

## epoxy primer xb

scheda  
tecnicadata  
sheetficha  
técnica

impregnante epossidico in fase solvente	interno esterno	epoxy impregnating agent diluted in solvent	indoor outdoor	impregnante epoxidico en disolución	interior exterior
<p>Formulato epossidico bicomponente trasparente a base di resine epossidiche e addotti sciolti in solventi appropriati, dotato di eccezionale adesione su supporti, ottima resistenza agli agenti atmosferici e chimici, idoneo per applicazioni in atmosfera industriale e marina. Appropriato come impregnante e promotore di adesione quando il manufatto deve essere finito con pitture epossidiche, epossiviniliche, poliuretaniche o clorocaucciù. Primer per Ivaglass. Per uso professionale.</p>		<p>Two-pack, transparent epoxy resin-based formulation containing adducts dissolved in appropriate solvents. Offers exceptional adhesion on mineral substrates, superb resistance to atmospheric and chemical agents, ideal for applications in industrial and marine atmospheres. Particularly suitable as impregnation coat and adhesion promoter when the element is to be finished with epoxy, epoxy-vinyl, polyurethane or chlorinated-rubber paints. Primer for Ivaglass. For professional use.</p>		<p>Formulación epoxidica bicomponente transparente a base de resinas epoxidicas y aductos disueltos en solventes apropiados, dotado de excepcional adhesión sobre soportes minerales, excelente resistencia a los agentes atmosféricos y químicos, idóneo para aplicaciones en atmósfera industrial y marina. Particularmente indicado como capa de impregnación y promotor de adhesión cuando el elemento deba recibir acabado con pinturas epoxidicas, epoxivinilicas, poliuretánicas o clorocaucho. Imprimación para Ivaglass. Para uso profesional.</p>	
<p><b>Attrezzatura:</b> pennello, rullo, airless <b>Rapporto di catalisi:</b> (A:B) 1:1 <b>Diluizione:</b> pronto uso <b>Resa</b> (1 mano): 150-250 g/m<sup>2</sup> - Per confezione (20+20 kg): 130 m<sup>2</sup> <b>Colore:</b> incolore</p>		<p><b>Equipment:</b> brush, roller, airless <b>Mixing ration:</b> (A:B) 1:1 <b>Dilution:</b> ready to use <b>Coverage</b> (1 coat): 150-250 g/m<sup>2</sup> - Per package (20+20 kg): 130 m<sup>2</sup> <b>Color:</b> transparent</p>		<p><b>Herramientas:</b> brocha, rodillo, pistola pulverizadora <b>Relación de catalisis:</b> (A:B) 1:1 <b>Dilución:</b> listo para usar <b>Rendimiento</b> (1 capa): 150-250 g/m<sup>2</sup> - Por envase (20+20 kg): 130 m<sup>2</sup> <b>Color:</b> incoloro</p>	

tecniche	certificazioni	proprietà	tecnologie
 WATER BASED  BRUSH  ROLLER  AIRLESS			

# primer mma



scheda  
tecnica



data  
sheet



ficha  
técnica



impregnante monocomponente in fase solvente <b>interno esterno</b>	single-component impregnating agent in the solvent phase <b>indoor outdoor</b>	impregnante monocomponente en fase disolvente <b>interior exterior</b>
Impregnante monocomponente trasparente a base di resine metacriliche in solvente per superfici in cls e malte cementizie. Presenta una buona resistenza alla contaminazione da oli, ai raggi UV ed attraverso speciali polimeri termoplastici, esplica azione protettiva, consolidante ed idrofobizzante sui supporti trattati. Per uso professionale.	One-pack, transparent, methacrylic resin-based impregnating agent in solvent for concrete and cement-based mortars. Offers good resistance to UV rays, to contamination from mineral oils and is waterproof. With its special thermoplastic polymers, Protects, consolidates and waterproofs the treated substrates. For professional use.	Impregnante monocomponente transparente a base de resinas metacrilicas en disolvente para superficies en cls y morteros de cemento. Es resistente a los rayos UV, presenta una buena resistencia a la contaminación por aceites minerales, impermeable. Primer A través de polimeros termoplásticos especiales, ejerce una acción protectora, consolidante e hidro-repelente sobre los soportes tratados. Para uso profesional.
<b>Attrezzatura:</b> pennello, rullo, airless <b>Diluizione:</b> pronto uso <b>Resa (1 mano):</b> 100-150 g/m <sup>2</sup> - Per confezione (20 kg): 200 m <sup>2</sup> <b>Colore:</b> incolore	<b>Equipment:</b> brush, roller, airless <b>Dilution:</b> ready to use <b>Coverage (1 coat):</b> 100-150 g/m <sup>2</sup> - Per package (20 kg): 200 m <sup>2</sup> <b>Color:</b> transparent	<b>Herramientas:</b> brocha, rodillo, pistola pulverizadora <b>Dilución:</b> listo para usar <b>Rendimiento (1 capa):</b> 100-150 g/m <sup>2</sup> - Por envase (20 kg): 200 m <sup>2</sup> <b>Color:</b> incolore

tecniche				certificazioni				proprietà				tecnologie				
SOLVENT BASED	BRUSH	ROLLER	AIRLESS					WALKABLE								

## epoxy fondo

scheda  
tecnicadata  
sheetficha  
técnica

promotore adesione epossidico	interno	epoxy adhesion promoter	indoor	promotor de adhesión epoxidico	interiores
<p>Promotore di adesione epossidico per pavimentazioni e rivestimenti. Formulato bicomponente a base di resine epossidiche contenente fillers minerali ed extenders in polvere, specifico per:</p> <p>a) usato tal quale per promuovere l'adesione delle fasi successive sul supporto b) additivato con carica quarzifera per realizzare rasature come fondi per pavimentazioni resinose. Per uso professionale.</p> <p><b>Attrezzatura:</b> pennello, rullo a pelo corto, spatole dentate per l'applicazione a spessore <b>Rapporto di catalisi:</b> come promotore di adesione (A:B) 80:20; come rasante di fondo (A:B:C) 80:20:70 <b>Diluizione:</b> Diluente per Epossidici - max 15% <b>Resa:</b> come promotore di adesione: 0,35 kg/m<sup>2</sup>; come rasante di fondo: 1,7 kg/m<sup>2</sup> per mm di spessore <b>Colore:</b> incolore</p>		<p>Two-pack epoxy resin-based formulation containing mineral fillers and powder extenders, specifically:</p> <p>a) used 'as is' to promote adhesion of subsequent phases to the substrate b) with the addition of quartz filler to create base skim coats for the resin-based flooring. For professional use.</p> <p><b>Equipment:</b> brush, roller, serrated spatulas for thick-coat application <b>Mixing ration:</b> as adhesion promoter(A:B) 80:20; as skimming base coat(a:b:c) 80:20:70 <b>Dilution:</b> Diluente per Epossidici - max 15% <b>Coverage:</b> as adhesion promoter: 0,35 kg/m<sup>2</sup>; as skimming base coat: 1,7 kg/m<sup>2</sup> per mm of thickness <b>Color:</b> transparent</p>		<p>Formulación bicomponente a base de resinas epoxidicas con rellenos minerales y extender en polvo, especifica para:</p> <p>a) usado tal cual para promover la adhesión de las fases sucesivas en el soporte b) aditivado con carga de cuarzos para realizar enrasados como fondos para suelos resinosos. Para uso profesional.</p> <p><b>Herramientas:</b> rodillos o brochas, espátulas dentadas para la aplicación en espesor <b>Relación de catalisis:</b> como promotor de adhesión A : B = 80 : 20 como mortero de enrasado de fondo A : B : C = 80 : 20 : 70 <b>Diluición:</b> Diluente per Epossidici - max 15% <b>Rendimiento:</b> como promotor de adhesión: 0,35 kg/m<sup>2</sup>; como mortero de enrasado de fondo: 1,7 kg/m<sup>2</sup> por mm de espesor <b>Color:</b> incoloro</p>	

tecniche				certificazioni				proprietà				tecnologie			

## epoxy fondo oil

scheda  
tecnicadata  
sheetficha  
técnica

promotore di adesione per fondi unti	interno	two-pack adhesion promoter for greasy substrates	indoor	promotor de adhesión para fondos con aceites	interiores
<p>Promotore di adesione epossidico bicomponente per fondi unti. Epoxy Fondo Oil è uno speciale primer di ancoraggio per superfici cementizie sporche di olio, previa una specifica preparazione del sottofondo. Per uso professionale.</p> <p><b>Attrezzatura:</b> pennello, rullo, airless <b>Rapporto di catalisi:</b> (A:B) 89:11 <b>Diluizione:</b> pronto uso <b>Resa</b> (1 mano): 500-600 g/m<sup>2</sup> - Per confezione (4,45+0,55 kg): 10 m<sup>2</sup> <b>Colore:</b> grigio</p>		<p>Two-pack epoxy-based adhesion promoter for greasy substrates Epoxy Fondo Oil is a special anchoring primer for cement-based surfaces soiled with oil, to be applied after specific preparation of the substrate. For professional use.</p> <p><b>Equipment:</b> brush, roller, airless <b>Mixing ration:</b> (A:B) 89:11 <b>Dilution:</b> ready to use <b>Coverage</b> (1 coat): 500-600 g/m<sup>2</sup> - Per package (4,45+0,55 kg): 10 m<sup>2</sup> <b>Color:</b> grey</p>		<p>Promotor de adhesión epoxidico bicomponente para fondos con aceites. Epoxy Fondo Oil es una imprimación de anclaje especial para superficies de cemento manchadas de aceite, previa preparación específica del sustrato. Para uso profesional.</p> <p><b>Herramientas:</b> brocha, rodillo, pistola pulverizadora <b>Relación de catalisis:</b> (A:B) 89:11 <b>Diluición:</b> listo para usar <b>Rendimiento</b> (1 capa): 500-600 g/m<sup>2</sup> - Por envase (4,45+0,55 kg): 10 m<sup>2</sup> <b>Color:</b> gris</p>	

tecniche				certificazioni				proprietà				tecnologie			

## epoxy fondo as



scheda  
tecnica



data  
sheet



ficha  
técnica



<p>promotore di adesione epossidico conduttivo</p> <p><b>interno</b></p>	<p>conductive epoxy-based adhesion promoter</p> <p><b>indoor</b></p>	<p>promotor de adhesión epoxidico conductor</p> <p><b>interiores</b></p>
<p>Formulato bicomponente a base di resine epossidiche in fase di solvente, fillers pregiati conduttivi, idoneo per la realizzazione di fondi per cicli di pavimentazioni autolivellanti antistatici. Per uso professionale.</p>	<p>Two-pack epoxy resin based formulation diluted in solvent, prime quality conductive fillers, suited to the creation of substrates for antistatic self-levelling flooring applications. For professional use.</p>	<p>Formulación bicomponente a base de resinas epoxidicas en disolución, rellenos preciados conductores, adecuada para la realización de fondos para ciclos de pisos autonivelantes antistáticos. Para uso profesional.</p>
<p><b>Attrezzatura:</b> pennello, rullo, airless <b>Rapporto di catalisi:</b> (A:B) 80:20 <b>Diluizione:</b> pronto all'uso <b>Resa (1 mano):</b> 150-200 g/m<sup>2</sup> - Per confezione (3+0,750 kg): 25 m<sup>2</sup> <b>Colore:</b> nero</p>	<p><b>Equipment:</b> brush, roller, airless <b>Mixing ratio:</b> (A:B) 80:20 <b>Dilution:</b> ready to use <b>Coverage (1 coat):</b> 150-200 g/m<sup>2</sup> - Per package (3+0,750 kg): 25 m<sup>2</sup> <b>Color:</b> black</p>	<p><b>Herramientas:</b> brocha, rodillo, pistola pulverizadora <b>Relación de catálisis:</b> (A:B) 80:20 <b>Dilución:</b> listo para usar <b>Rendimiento (1 capa):</b> 150-200 g/m<sup>2</sup> - Por envase (3+0,750 kg): 25 m<sup>2</sup> <b>Color:</b> negro</p>

tecniche	certificazioni	proprietà	tecnologie
SOLVENT BASED BRUSH ROLLER AIRLESS			

## aquacem



scheda  
tecnica



data  
sheet



ficha  
técnica



<p>primer tricomponente per fondi umidi</p> <p><b>interno esterno</b></p>	<p>three-pack primer for damp substrates</p> <p><b>indoor outdoor</b></p>	<p>imprimación tricomponente para fondos húmedos</p> <p><b>interior exterior</b></p>
<p>Promotore di adesione epossicementizio tricomponente, a base di resine epossidiche in emulsione acquosa, cemento, addotti, inerti. Idoneo per fondi umidi. Per uso professionale.</p>	<p>Three-pack epoxy-cement adhesion promoter, based on epoxy resins in water emulsion, cement, adducts, and inert materials. Suitable for damp substrates. For professional use.</p>	<p>Promotor de adhesión epoxicementoso tricomponente, a base de resinas epoxidicas en emulsión acuosa, cemento, aductos, inertes. Idóneo para fondos húmedos. Para uso profesional.</p>
<p><b>Attrezzatura:</b> pennello, rullo, spatola <b>Rapporto di catalisi:</b> (A:B:C) 1:2:5 <b>Diluizione:</b> acqua - pennello, rullo max 15% - spatola pronto all'uso <b>Resa:</b> 1,5 kg/m<sup>2</sup> per mm di spessore <b>Colore:</b> grigio</p>	<p><b>Equipment:</b> brush, roller, spatula <b>Mixing ratio:</b> (A:B:C) 1:2:5 <b>Dilution:</b> water - brush, roller max 15% - spatula: ready to use <b>Coverage:</b> 1,5 kg/m<sup>2</sup> per mm of thickness <b>Color:</b> grey</p>	<p><b>Herramientas:</b> brocha, rodillo, espátula <b>Relación de catálisis:</b> (A:B:C) 1:2:5 <b>Dilución:</b> agua - brocha, rodillo max 15% - espátula listo para usar <b>Rendimiento:</b> 1,5 kg/m<sup>2</sup> per mm de espesor <b>Color:</b> gris</p>

tecniche	certificazioni	proprietà	tecnologie
WATER BASED BRUSH ROLLER TROWEL			

## aquacem autolivellante



scheda  
tecnica



data  
sheet



ficha  
técnica



<p>malta di fondo autolivellante</p> <p><b>interno esterno</b></p>	<p>self-levelling mortar for base coat</p> <p><b>indoor outdoor</b></p>	<p>mortero autonivelante para capa de fondo</p> <p><b>interior exterior</b></p>
<p>Malta autolivellante per strato di fondo per supporti cementizi umidi o in leggera contropinta, di pavimentazioni, serbatoi, fognature, vasche, canali. Formulato tri componente autolivellante ad alta resistenza a base di resine epossidiche in dispersione acquosa e leganti idraulici. Per uso professionale.</p>	<p>Self-levelling mortar for base coat on concrete substrates that are damp or present slight counterthrust, for flooring, tanks, sewers, basens, canals, etc. Two-pack, self-levelling, high resistance epoxy resin-based formulation dispersed in water and hydraulic binders. For professional use.</p>	<p>Mortero autonivelante para capa de fondo para soportes de cemento húmedos o en empuje negativo ligero, de suelos, depósitos, alcantarillados, cubas, canales. Fórmula bicomponente autonivelante de alta resistencia a base de resinas epoxidicas en dispersión acuosa y aglutinantes hidráulicos. Para uso profesional.</p>
<p><b>Attrezzatura:</b> Spatola dentata e rullo frangibolle per l'applicazione a spessore <b>Rapporto di catalisi:</b> (A:B:C) 9:7:84 <b>Diluizione:</b> pronto uso <b>Resa:</b> 2 kg/m<sup>2</sup> per mm di spessore <b>Colore:</b> grigio</p>	<p><b>Equipment:</b> Serrated spatula e bubble-buster roller for thick-coat application <b>Mixing ratio:</b> (A:B:C) 9:7:84 <b>Dilution:</b> ready to use <b>Coverage:</b> 2 kg/m<sup>2</sup> per mm of thickness <b>Color:</b> grey</p>	<p><b>Herramientas:</b> Espátula dentada y rodillo antiburbujas para aplicación de espesor <b>Relación de catálisis:</b> (A:B:C) 9:7:84 <b>Dilución:</b> listo para usar <b>Rendimiento:</b> 2 kg/m<sup>2</sup> per mm de espesor <b>Color:</b> gris</p>

tecniche	certificazioni	proprietà	tecnologie
WATER BASED ROLLER TROWEL			

## epoxy bond



scheda  
tecnica



data  
sheet



ficha  
técnica



legante bicomponente per malte	interno	two-pack binder for mortars	indoor	Aglutinante bicomponente para morteros	interiores
Legante bicomponente a base di resine epossidiche, esente da solventi, trasparente, per la realizzazione di massetti di spessore variabile tra 5 e 10 mm. Idoneo per la realizzazione di malte resinose per pavimentazioni industriali ad alta resistenza meccanica. Per uso professionale.		Two pack, solvent-free, transparent epoxy resin binder to produce screeds with thickness ranging from 5 to 10 mm. Ideal for resin mortars for industrial floorings requiring high mechanical resistance. For professional use.		Aglutinante bicomponente a base de resinas epoxídicas, sin disolventes, para la realización de soleras de espesor variable entre 5 y 10 mm. Idóneo para la realización de morteros resinosos para suelos industriales de alta resistencia mecánica. Para uso profesional.	
<b>Attrezzatura:</b> Stagge e frattazzi manuali o meccanici, rullo in lana a pelo corto <b>Rapporto di catalisi:</b> (A:B) 66:33 <b>Diluizione:</b> pronto uso <b>Resa:</b> 2 kg/m <sup>2</sup> per mm di spessore <b>Colore:</b> grigio <b>Color:</b> incolore		<b>Equipment:</b> Manual or mechanical leveling bars and trowels, roller <b>Mixing ration:</b> (A:B) 66:33 <b>Dilution:</b> ready to use <b>Coverage:</b> 2 kg/m <sup>2</sup> per mm of thickness <b>Colours:</b> grey <b>Color:</b> transparent		<b>Herramientas:</b> Reglas y llanas manuales o mecánicas <b>Relación de catálisis:</b> (A:B) 66:33 <b>Dilución:</b> listo para usar <b>Rendimiento:</b> 2 kg/m <sup>2</sup> per mm de espesor <b>Color:</b> gris <b>Color:</b> incoloro	

tecniche		certificazioni				proprietà				tecnologie			
													
TROWEL	ROLLER												



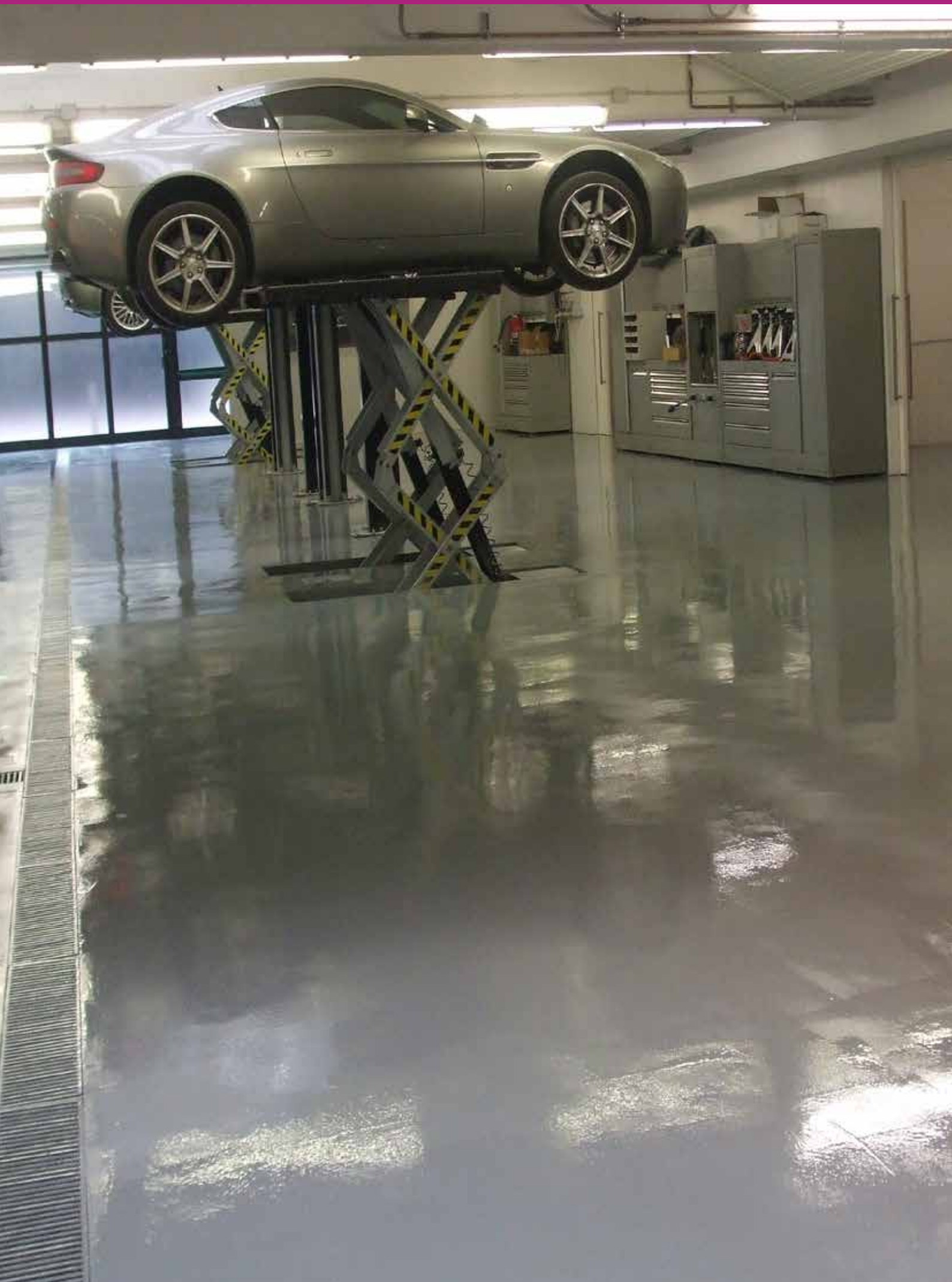

## aquapox

scheda  
tecnicadata  
sheetficha  
técnica

smalto all'acqua dall'elevata resistenza	<b>interno</b>	highly resistant water-based enamel	<b>indoor</b>	esmalte al agua de alta resistencia	<b>interiores</b>
Rivestimento epossidico bicomponente in dispersione acquosa per film sottile. Particolarmente idoneo per il trattamento di superfici sia orizzontali che verticali, che richiedono elevate resistenze meccaniche, chimiche e all'idrolavaggio. Certificato come verniciatura di ambienti con presenza di alimenti secondo la norma UNI 11020:2002. Per uso professionale.		Two-pack, epoxy resin-based coating in aqueous dispersion for thin films. Particularly suited for treating horizontal and vertical surfaces requiring high mechanical and chemical resistance and high resistance to high-pressure washing. Certified as paint for areas where foodstuffs are present, in accordance with UNI 11020:2002 standard. For professional use.		Revestimiento epoxídico bicomponente en dispersión acuosa para película fina. Particolarmente idóneo para el tratamiento de superficies, tanto horizontales como verticales, que requieran elevadas resistencias mecánicas, químicas y para hidrolavado. Certificado como barniz para espacios con presencia de alimentos según la norma UNI 11020:2002. Para uso profesional.	
<b>Attrezzatura:</b> pennello, rullo, airless <b>Rapporto di catalisi:</b> (A:B) 70:30 <b>Diluizione:</b> acqua - max 10-20% <b>Resa</b> (2 mani): 3-3,5 m <sup>2</sup> /l - Per confezione (10,5+4,5 kg): 56 m <sup>2</sup> <b>Colore:</b> colorato		<b>Equipment:</b> brush, roller, airless <b>Mixing ration:</b> (A:B) 70:30 <b>Dilution:</b> water - max 10-20% <b>Coverage</b> (2 coats): 3-3,5 m <sup>2</sup> /l - Per package (10,5+4,5 kg): 56 m <sup>2</sup> <b>Color:</b> colored		<b>Herramientas:</b> brocha, rodillo, pistola pulverizadora <b>Relación de catalisis:</b> (A:B) 70:30 <b>Dilución:</b> agua - max 10-20% <b>Rendimiento</b> (2 capas): 3-3,5 m <sup>2</sup> /l - Por envase (10,5+4,5 kg): 56 m <sup>2</sup> <b>Color:</b> colorido	

tecniche	certificazioni	proprietà	tecnologie
 WATER BASED  BRUSH  ROLLER  AIRLESS		 CARRIAGEABLE	 resistance 4

## epoxy paint ht

scheda  
tecnicadata  
sheetficha  
técnica

rivestimento epossidico per film spesso	<b>interno</b>	epoxy resin-based coating for thick film	<b>indoor</b>	revestimiento epoxídico para película gruesa	<b>interiores</b>
Rivestimento epossidico bicomponente per film spesso pigmentato, esente da solventi, per rivestimenti di pavimentazioni industriali con buone resistenze chimiche, ottima impermeabilità ad oli ed agenti aggressivi, ottima resistenza ai lavaggi e all'usura causata dal traffico leggero di carrelli. Contiene fillers minerali specifici per la realizzazione di finiture lucide di pavimentazioni a film spesso compreso tra 0.2 e 1 mm e rivestimenti multistrato compresi tra 1 e 3 mm ad effetto liscio e monocromatico. Per uso professionale.		Solvent-free, two-pack, pigmented thick film, epoxy resin-based coating for industrial flooring with good chemical resistance, excellent impermeability to oils and aggressive agents, excellent resistance to washing and wear caused by light trolley traffic. Contains mineral fillers specifically designed for the creation of glossy floor finishes with a thick film between 0.2 and 1.0 mm and multi-layer coatings between 1 and 3 mm thick with a smooth, monochromatic effect. For professional use.		Revestimiento epoxídico bicomponente para película gruesa pigmentada, sin solventes, para revestimiento de suelos industriales con buena resistencia química, excelente impermeabilidad a los aceites y agentes agresivos, excelente resistencia a los lavados y al desgaste causado por tráfico ligero de carritos. Contiene rellenos minerales específicos para la realización de acabados brillantes de suelos con película de espesor entre 0,2 y 1 mm, y revestimientos multicapa entre 1 y 3 mm de efecto liso y monocromático. Para uso profesional.	
<b>Attrezzatura:</b> rullo a pelo corto <b>Rapporto di catalisi:</b> (A:B) 80:20 <b>Diluizione:</b> Diluente per Epossidici - max 5% <b>Resa</b> (2 mani): 500-700 g/m <sup>2</sup> - Per confezione (16+4 kg): 40 m <sup>2</sup> <b>Colore:</b> colorato		<b>Equipment:</b> roller <b>Mixing ration:</b> (A:B) 80:20 <b>Dilution:</b> Diluente per Epossidici - max 5% <b>Coverage</b> (2 coats): 500-700 g/m <sup>2</sup> - Per package (16+4 kg): 40 m <sup>2</sup> <b>Color:</b> colored		<b>Herramientas:</b> rodillo a pelo corto <b>Relación de catalisis:</b> (A:B) 80:20 <b>Dilución:</b> Diluente per Epossidici - max 5% <b>Rendimiento</b> (2 capas): 500-700 g/m <sup>2</sup> - Por envase (16+4 kg): 40 m <sup>2</sup> <b>Color:</b> colorido	

tecniche	certificazioni	proprietà	tecnologie
 SOLVENT BASED  BRUSH  ROLLER  TROWEL		 CARRIAGEABLE	

## epoxy paint It



scheda  
tecnica



data  
sheet



ficha  
técnica



rivestimento epossidico per film sottile <b>interno</b>	epoxy resin-based coating for thin film <b>indoor</b>	revestimiento epoxídico para película fina <b>interiores</b>
Rivestimento bicomponente a base di resine epossidiche in fase solvente, pigmenti e cariche pregiate, caratterizzato da buone resistenze agli agenti chimici e superficiali. Idoneo per la realizzazione di rivestimenti a film di spessore compresi tra 100 e 200 µm su pavimentazioni industriali a traffico leggero. I rivestimenti che si ottengono sono impermeabili all'acqua, agli oli e al vapore. Per uso professionale.	Two-pack epoxy resin-based coating in solvent phase. Contains pigments and prime quality fillers that offer good resistance to chemical and surface agents. Suitable for film coating of industrial floors subject to light traffic, car parks, warehouses — thickness ranging between 100 and 200 µm. The resulting coatings are impermeable to water, oil and steam. For professional use.	Revestimiento bicomponente a base de resinas epoxídicas en disolución, pigmentos y cargas refinadas, caracterizado por buenas resistencias a los agentes químicos y superficiales. Idóneo para la realización de películas de revestimiento con espesores entre 100 y 200 µm sobre suelos industriales de tráfico ligero, depósitos de vehículos, almacenes. Los revestimientos que se obtienen son impermeables al agua, a los aceites y al vapor. Para uso profesional.
<b>Attrezzatura:</b> pennello, rullo, airless <b>Rapporto di catalisi:</b> (A:B) 75:25 <b>Diluizione:</b> Diluente per Epossidici - max 10% <b>Resa</b> (2 mani): 0,3-0,4 kg/m <sup>2</sup> pari ad uno spessore di circa 150/200 micron - Per confezione (12+4 kg): 6,6 m <sup>2</sup> <b>Colore:</b> colorato	<b>Equipment:</b> brush, roller, airless <b>Mixing ration:</b> (A:B) 75:25 <b>Dilution:</b> Diluente per Epossidici - max 10% <b>Coverage</b> (2 coats): 0,3-0,4 kg/m <sup>2</sup> approx. 150/200 micron Per package (12+4 kg): 6,6 m <sup>2</sup> <b>Color:</b> colored	<b>Herramientas:</b> brocha, rodillo, pistola pulverizadora <b>Relación de catálisis:</b> (A:B) 75:25 <b>Dilución:</b> Diluente per Epossidici - max 10% <b>Rendimiento</b> (2 capas): 0,3-0,4 kg/m <sup>2</sup> igual a un espesor de aprox.150/200 micron- Por envase (12+4 kg): 6,6 m <sup>2</sup> <b>Color:</b> colorido

tecniche	certificazioni	proprietà	tecnologie
SOLVENT BASED BRUSH ROLLER AIRLESS		CARRIAGEABLE	

## davis paint



scheda  
tecnica



data  
sheet



ficha  
técnica



microrivestimento antiscivolo <b>esterno</b>	non-slip micro-coating <b>outdoor</b>	micro-revestimiento antideslizante <b>steriores</b>
Microrivestimento monocomponente acrilico all'acqua. Particolarmente idoneo per pavimentazioni in asfalto, cementizie, sintetiche, bituminose (campi da tennis). Ottimo anche su supporti murari. Il film è impermeabile, resistente agli alcali, all'abrasione, alle intemperie in atmosfere moderatamente industriali. Per uso professionale.	One-pack, water-based micro-coating. Ideal for asphalt, concrete, synthetic, bituminous floorings (tennis courts). Superb also on masonry substrates. The film is waterproof, resistant to alkalis, abrasion and bad weather in moderately industrial atmospheres. For professional use.	Micro-revestimiento monocomponente al agua. Particolarmente idóneo para pisos en asfalto, cemento, sintéticos, bituminosos (campos de tenis). Excelente también en paredes. La película es impermeable, resistente a los álcalis, a la abrasión, a la intemperie en atmósferas moderadamente industriales. Para uso profesional.
<b>Attrezzatura:</b> pennello, rullo, airless <b>Diluizione:</b> acqua - max 25% <b>Resa</b> (2 mani): 4-5 m <sup>2</sup> /l - Per confezione (14 l): 70 m <sup>2</sup> <b>Colore:</b> Verde, Rosso tennis, Bianco	<b>Equipment:</b> brush, roller, airless <b>Dilution:</b> water - max 25% <b>Coverage</b> (2 coats): 4-5 m <sup>2</sup> /l - Per package (14 l): 70 m <sup>2</sup> <b>Color:</b> Green, tennis court clay Red, White	<b>Herramientas:</b> brocha, rodillo, pistola pulverizadora <b>Dilución:</b> agua - max 25% <b>Rendimiento</b> (2 capas): 4-5 m <sup>2</sup> /l - Por envase (14 l): 70 m <sup>2</sup> <b>Color:</b> Verde, Rojo tennis, Blanco

tecniche	certificazioni	proprietà	tecnologie
WATER BASED BRUSH ROLLER AIRLESS		WALKABLE	

## paviglass lucido

scheda  
tecnicadata  
sheetficha  
técnica

smalto a solvente ad elevata resistenza	interno esterno	highly resistant solvent-based enamel	indoor outdoor	esmalte con disolvente de alta resistencia.	interior exterior
Formulato acrilpoliuretano bicomponente, induritore isocianato alifatico non ingiallente, idoneo per rivestimenti di pavimentazioni industriali con buone resistenze chimiche e agli oli, adatto quindi per industrie chimiche, farmaceutiche, meccaniche, elettriche, garage e autorimesse. Per uso professionale.		Two-pack acrylic-polyurethane formulation, non-yellowing, aliphatic, isocyanate hardener, suitable for coating industrial flooring requiring good resistance to chemicals and oils. It is thus particularly suited for use in chemical, pharmaceutical, mechanical, electrical industries and in garages and covered car parks. For professional use.		Fórmula acrilpoliuretánica bicomponente, endurecedor isocianato alifático, no amarillea, idóneo para revestimientos de pisos industriales con buenas resistencias químicas y a los aceites, adecuado, por tanto, para industrias químicas, farmacéuticas, mecánicas, eléctricas, garajes y cocheras. Para uso profesional.	
<b>Attrezzatura:</b> pennello, rullo, airless <b>Rapporto di catalisi:</b> (A:B) 3:1 <b>Diluizione:</b> Diluente per Poliuretani (non utilizzare diluenti nitro) - max 10% <b>Resa</b> (2 mani): 4-4,5 m <sup>2</sup> /l - Per confezione (12+4 l): 70 m <sup>2</sup> <b>Colore:</b> colorato		<b>Equipment:</b> brush, roller, airless <b>Mixing ration:</b> (A:B) 3:1 <b>Dilution:</b> Diluente per Poliuretani (do not use diluenti nitro) - max 10% <b>Coverage</b> (2 coats): 4-4,5 m <sup>2</sup> /l - Per package (12+4 l): 70 m <sup>2</sup> <b>Color:</b> colored		<b>Herramientas:</b> brocha, rodillo, pistola pulverizadora <b>Relación de catálisis:</b> (A:B) 3:1 <b>Dilución:</b> Diluente per Poliuretani (no utilizar diluenti nitro) - max 10% <b>Rendimiento</b> (2 capas): 4-4,5 m <sup>2</sup> /l - Por envase (12+4 l): 70 m <sup>2</sup> <b>Color:</b> colorido	

tecniche	certificazioni	proprietà	tecnologie

## paviglass opaco

scheda  
tecnicadata  
sheetficha  
técnica

smalto a solvente ad elevata resistenza	interno esterno	highly resistant solvent-based enamel	indoor outdoor	esmalte con disolvente de alta resistencia.	interior exterior
Formulato acrilpoliuretano bicomponente, induritore isocianato alifatico non ingiallente, idoneo per rivestimenti di pavimentazioni industriali con buone resistenze chimiche e agli oli, adatto quindi per industrie chimiche, farmaceutiche, meccaniche, elettriche, garage e autorimesse. Per uso professionale.		Two-pack acrylic-polyurethane formulation, non-yellowing, aliphatic, isocyanate hardener, suitable for coating industrial flooring requiring good resistance to chemicals and oils. It is thus particularly suited for use in chemical, pharmaceutical, mechanical, electrical industries and in garages and covered car parks. For professional use.		Fórmula acrilpoliuretánica bicomponente, endurecedor isocianato alifático, no amarillea, idóneo para revestimientos de pisos industriales con buenas resistencias químicas y a los aceites, adecuado, por tanto, para industrias químicas, farmacéuticas, mecánicas, eléctricas, garajes y cocheras. Para uso profesional.	
<b>Attrezzatura:</b> pennello, rullo, airless <b>Rapporto di catalisi:</b> (A:B) 3:1 <b>Diluizione:</b> Diluente per Poliuretani (non utilizzare diluenti nitro) - max 10% <b>Resa</b> (2 mani): 4-4,5 m <sup>2</sup> /l - Per confezione (12+4 l): 70 m <sup>2</sup> <b>Colore:</b> colorato		<b>Equipment:</b> brush, roller, airless <b>Mixing ration:</b> (A:B) 3:1 <b>Dilution:</b> Diluente per Poliuretani (do not use diluenti nitro) - max 10% <b>Coverage</b> (2 coats): 4-4,5 m <sup>2</sup> /l - Per package (12+4 l): 70 m <sup>2</sup> <b>Color:</b> colored		<b>Herramientas:</b> brocha, rodillo, pistola pulverizadora <b>Relación de catálisis:</b> (A:B) 3:1 <b>Dilución:</b> Diluente per Poliuretani (no utilizar diluenti nitro) - max 10% <b>Rendimiento</b> (2 capas): 4-4,5 m <sup>2</sup> /l - Por envase (12+4 l): 70 m <sup>2</sup> <b>Color:</b> colorido	

tecniche	certificazioni	proprietà	tecnologie







## ivapox antiacido

 scheda  
tecnica

 data  
sheet

 ficha  
técnica

smalto bicomponente antiacido	interno	two-pack anti-acid enamel	indoor	esmalte bicomponente antiácido	interiores
<p>Smalto formulato a base di resine epossidiche non modificate, bicomponente, esente da solventi. Particolarmente indicato per la protezione di manufatti da aggressivi chimici sia acidi diluiti che soluzioni altamente alcaline, oli, vegetali, soluzione saline e alcuni tipi di solventi. Tali capacità di resistenza si realizzano al 100% solo ad indurimento totale, cioè almeno dopo 7 giorni dall'applicazione. Per uso professionale.</p>		<p>Two-pack solvent-free, non modified epoxy resin-based enamel with superb chemical characteristics and good physical and mechanical properties. Particularly suited to protect surfaces from chemical agents such as diluted acids and highly alkaline solutions, mineral and vegetable oils, saline solutions and some types of solvents. 100% resistance is only achieved after full hardening time has elapsed, that is 7 days after application. For professional use.</p>		<p>Formulación a base de resinas epoxídicas no modificadas, bicomponente, sin disolventes. Particolarmente indicado para proteger objetos de agentes químicos agresivos, tanto ácidos diluidos como soluciones altamente alcalinas, aceites minerales, vegetales, soluciones salinas y algunos tipos de disolventes. Estas capacidades de resistencia se realizan al 100 % solo una vez endurecido completamente, es decir, al menos 7 días después de la aplicación. Para uso profesional.</p>	
<p><b>Attrezzatura:</b> pennello, rullo, airless <b>Rapporto di catalisi:</b> (A:B) 80:20 <b>Diluizione:</b> pronto uso <b>Resa</b> (2 mani): 250-300 g/m<sup>2</sup> - Per confezione (16+4 kg): 80 m<sup>2</sup> <b>Colore:</b> Grigio, Rosso Ossido, Giallo Ocra, Verde</p>		<p><b>Equipment:</b> brush, roller, airless <b>Mixing ration:</b> (A:B) 80:20 <b>Dilution:</b> ready to use <b>Coverage</b> (2 coats): 250-300 g/m<sup>2</sup> - Per package (16+4 kg): 80 m<sup>2</sup> <b>Color:</b> Grey, Oxide Red, Ochre Yellow, Green</p>		<p><b>Herramientas:</b> brocha, rodillo, pistola pulverizadora <b>Relación de catálisis:</b> (A:B) 80:20 <b>Dilución:</b> listo para usar <b>Rendimiento</b> (2 capas): 250-300 g/m<sup>2</sup> - Por envase (16+4 kg): 80 m<sup>2</sup> <b>Color:</b> Gris, Rojo Óxido, Amarillo Ocra, Verde</p>	

tecniche			certificazioni			proprietà			tecnologie		
											
BRUSH	ROLLER	AIRLESS				CARRIAGEABLE					



## epoplast

 scheda  
tecnica

 data  
sheet

 ficha  
técnica

legante per malte autolivellanti	interno	binder for self-levelling mortars	indoor	aglutinante para morteros autonivelantes	interiores
<p>Formulato bicomponente pigmentato a base di resine epossidiche, contenente fillers minerali ed extenders in polvere specifico per pavimentazioni industriali resinose, aventi caratteristiche meccaniche e chimiche idonee. Permette di realizzare malte autolivellanti aggiungendo al legante (comp. A + comp. B), la carica quarzifera (Comp. C) Quarzo 06 in rapporto 1:0,7 e di ottenere delle superfici con grado di finitura lucido. I rivestimenti sono impermeabili all'acqua ed agli oli e perfettamente lavabili con detersivi neutri. Per uso professionale.</p>		<p>Two-pack pigmented epoxy resin-based formulation containing mineral fillers and powdered extenders for the creation of self-levelling mortars. EPOPLAST makes it possible to produce self-levelling mortars by adding the quartz filler Quarzo 06 (IVAS) (Pack C) to the binder (pack A + pack B) in a ratio of 1:0.7 and to obtain surfaces with a glossy finish. The coatings are waterproof, oil-proof and perfectly washable with neutral detergents. For professional use.</p>		<p>Formulación bicomponente pigmentada con base de resinas epoxídicas, contiene rellenos minerales y extender en polvo; específica para suelos industriales resinosos, de características mecánicas y químicas adecuadas. Permite realizar morteros autonivelantes añadiendo al aglutinante (comp.A + comp.B), la carga de cuarzo (Comp.C) Quarzo 06 en relación 1:0,7 y obtener superficies con un grado de acabado brillante. Los revestimientos son impermeables al agua y a los aceites, y perfectamente lavables con detergentes neutros. Para uso profesional.</p>	
<p><b>Attrezzatura:</b> pennello, rullo, airless <b>Rapporto di catalisi:</b> (A:B:C) 80:20:70 <b>Diluizione:</b> pronto uso <b>Resa:</b> 1,8 kg/m<sup>2</sup> per mm di spessore <b>Colore:</b> colorato</p>		<p><b>Equipment:</b> brush, roller, airless <b>Mixing ration:</b> (A:B:C) 80:20:70 <b>Dilution:</b> ready to use <b>Coverage:</b> 1,8 kg/m<sup>2</sup> per mm of thickness <b>Color:</b> colored</p>		<p><b>Herramientas:</b> brocha, rodillo, pistola pulverizadora <b>Relación de catálisis:</b> (A:B:C) 80:20:70 <b>Dilución:</b> listo para usar <b>Rendimiento:</b> 1,8 kg/m<sup>2</sup> per mm de espesor <b>Color:</b> colorido</p>	

tecniche	certificazioni	proprietà	tecnologie

## epoplast w

 scheda  
tecnica

 data  
sheet

 ficha  
técnica

epossidica autolivellante a base acquosa	interno	water-based, self-levelling epoxy formulation	indoor	formulación epoxídica autonivelante al agua	interiores
<p>Formulato bicomponente pigmentato a base di resine epossidiche in emulsione acquosa, per la realizzazione di malte autolivellanti. Per uso professionale.</p>		<p>Two-pack pigmented epoxy resin-based formulation in aqueous emulsion, for the creation of self-levelling mortars. For professional use.</p>		<p>Formulación bicomponente pigmentada con base de resinas epoxídicas en emulsión acuosa, para la realización de morteros autonivelantes. Para uso profesional.</p>	
<p><b>Attrezzatura:</b> spatola dentata, rullo frangibolle <b>Rapporto di catalisi:</b> (A:B:C) 80:20:30 <b>Diluizione:</b> pronto uso <b>Resa:</b> 2 kg/m<sup>2</sup> per mm di spessore <b>Colore:</b> colorato</p>		<p><b>Equipment:</b> serrated spatula, bubble-buster roller <b>Mixing ration:</b> (A:B:C) 80:20:30 <b>Dilution:</b> ready to use <b>Coverage:</b> 2 kg/m<sup>2</sup> per mm of thickness <b>Color:</b> colored</p>		<p><b>Herramientas:</b> espátula dentada, rodillo antiburbujas <b>Relación de catálisis:</b> (A:B:C) 80:20:30 <b>Dilución:</b> listo para usar <b>Rendimiento:</b> 2 kg/m<sup>2</sup> per mm de espesor <b>Color:</b> colorido</p>	

tecniche	certificazioni	proprietà	tecnologie

# epoplast as



scheda  
tecnica



data  
sheet



ficha  
técnica



finitura ciclo autolivellante antistatica	<b>interno</b>	antistatic self-levelling cycle topcoat	<b>indoor</b>	acabado de ciclo autonivelante antiestático	<b>interiores</b>
<p>Formulato bicomponente pigmentato a base di resine epossidiche, contenenti fillers conduttivi, idoneo per la realizzazione di finiture di cicli di pavimentazioni autolivellanti antistatiche secondo la norma UNI8298-10. La sinergia tra la proprietà antistatica e le notevoli caratteristiche meccaniche e chimiche, lo rendono specificamente indicato per industrie chimiche e farmaceutiche, ospedali e sale operatorie, industrie elettriche ed elettroniche, ambienti antidefragranti. Per uso professionale.</p>		<p>Two-pack pigmented epoxy resin-based formulation containing conductive fillers, suited for finishing self-levelling antistatic flooring as per UNI8298-10. The synergy between antistatic characteristics and superb mechanical and chemical properties make Epoplast AS particularly suited to use in chemical and pharmaceutical industries, hospitals and operating theatres, precision engineering industries, electrical and electronic industries, flameproof environments For professional use.</p>		<p>Formulación bicomponente pigmentada a base de resinas epoxidicas; contiene rellenos conductores, idónea para la realización de acabados de ciclos de pisos autonivelantes antiestáticos conforme a la norma UNI8298-10. La sinergia entre la propiedad antiestática y las notables características mecánicas y químicas, hacen Epoplast AS específicamente indicado para industrias químicas y farmacéuticas, hospitales y quirófanos, industrias mecánicas de precisión, industrias eléctricas y electrónicas, espacios antideflagrantes. Para uso profesional.</p>	
<p><b>Attrezzatura:</b> spatola dentata, rullo <b>Rapporto di catalisi:</b> (A:B) 86:14 <b>Diluizione:</b> pronto uso <b>Resa:</b> 2,2 kg/m<sup>2</sup> per mm di spessore <b>Colore:</b> colorato</p>		<p><b>Equipment:</b> serrated spatula, roller <b>Mixing ration:</b> (A:B) 86:14 <b>Dilution:</b> ready to use <b>Coverage:</b> 2,2 kg/m<sup>2</sup> per mm of thickness <b>Color:</b> colored</p>		<p><b>Herramientas:</b> espátula dentada, rodillo <b>Relación de catalisis:</b> (A:B) 86:14 <b>Dilución:</b> listo para usar <b>Rendimiento:</b> 2,2 kg/m<sup>2</sup> per mm de espesor <b>Color:</b> colorido</p>	

<b>tecniche</b>	<b>certificazioni</b>	<b>proprietà</b>	<b>tecnologie</b>
SOLVENT BASED TROWEL ROLLER		CARRIAGEABLE	

# epoplast flex



scheda  
tecnica



data  
sheet



ficha  
técnica



epossi-poliuretano per malte autolivellanti	<b>interno</b>	epoxy-polyurethane formulation for self-levelling mortars	<b>indoor</b>	epoxi-poliuretánica para morteros autonivelantes	<b>interiores</b>
<p>Formulato bicomponente tricomponente epossi-poliuretano pigmentato per la realizzazione di malte autolivellanti elastoplastiche pedonabili per pavimentazioni caratterizzate da buona resistenza meccanica e chimica, impermeabili a vapore, acqua, oli. Per uso professionale.</p>		<p>Three-pack, epoxy-polyurethane formulation for walkable, elastoplastic self-levelling mortars for flooring that are impermeable to water vapour, water and oils and have a good mechanical and chemical resistance. For professional use.</p>		<p>Formulación epoxi-poliuretánica tricomponente, para la realización de morteros autonivelantes elastoplásticos válidos para tránsito peatonal, para suelos caracterizados por una buena resistencia mecánica y química, impermeable al vapor, agua, aceite. Para uso profesional.</p>	
<p><b>Attrezzatura:</b> pennello, rullo, airless <b>Rapporto di catalisi:</b> (A:B:C) 70:30:50 <b>Diluizione:</b> pronto uso <b>Resa:</b> 1,7 kg/m<sup>2</sup> per mm di spessore <b>Colore:</b> colorato</p>		<p><b>Equipment:</b> brush, roller, airless <b>Mixing ration:</b> (A:B:C) 70:30:50 <b>Dilution:</b> ready to use <b>Coverage:</b> 1,7 kg/m<sup>2</sup> per mm of thickness <b>Color:</b> colored</p>		<p><b>Herramientas:</b> brocha, rodillo, pistola pulverizadora <b>Relación de catalisis:</b> (A:B:C) 70:30:50 <b>Dilución:</b> listo para usar <b>Rendimiento:</b> 1,7 kg/m<sup>2</sup> per mm de espesor <b>Color:</b> colorido</p>	

<b>tecniche</b>	<b>certificazioni</b>	<b>proprietà</b>	<b>tecnologie</b>
BRUSH ROLLER AIRLESS		CARRIAGEABLE	

## polyelastic

 scheda  
tecnica

 data  
sheet

 ficha  
técnica

rivestimento autolivellante elastico	<b>interno esterno</b>	elastic self-levelling coating	<b>indoor outdoor</b>	revestimiento autonivelante elástico	<b>interior exterior</b>
Rivestimento autolivellante elastico bicomponente poliuretano per la realizzazione di malte autolivellanti elastoplastiche pedonabili, utilizzabile anche a rullo come rivestimento a basso spessore elastico. Per uso professionale.		Two-pack elastic, polyurethane coating for the production of elastic-plastic self-levelling mortars that can be walked on; can also be applied by roller as a coating with low elastic thickness. For professional use.		Revestimiento autonivelante elástico bicomponente poliuretánico para la realización de morteros autonivelantes elastoplásticos válidos para tránsito peatonal, utilizable también con rodillo como revestimiento de bajo espesor elástico. Para uso profesional.	
<b>Attrezzatura:</b> spatola dentata, rullo frangibolle <b>Rapporto di catalisi:</b> (A:B) 100:15 <b>Diluizione:</b> Diluente per Epossidici - max 15% <b>Resa:</b> 1,75 kg/m <sup>2</sup> per mm di spessore <b>Colore:</b> colorato		<b>Equipment:</b> serrated spatula, bubble-buster roller <b>Mixing ration:</b> (A:B) 100:15 <b>Dilution:</b> Diluente per Epossidici - max 15% <b>Coverage:</b> 1,75 kg/m <sup>2</sup> per mm of thickness <b>Color:</b> colored		<b>Herramientas:</b> Espátula dentada y rodillo antiburbujas para aplicación de espesor <b>Relación de catalisis:</b> (A:B) 100:15 <b>Dilución:</b> Diluente per Epossidici - max 15% <b>Rendimiento:</b> 1,75 kg/m <sup>2</sup> per mm de espesor <b>Color:</b> colorido	

tecniche	certificazioni	proprietà	tecnologie
SOLVENT BASED TROWEL ROLLER		WALKABLE	

## epoplast 61

 scheda  
tecnica

 data  
sheet

 ficha  
técnica

resina epossidica autolivellante	<b>interno</b>	self-levelling epoxy resin	<b>indoor</b>	resina epoxídica autonivelante	<b>interiores</b>
Formulato bicomponente a base di resine epossidiche modificate ed additivi speciali, trasparente, a bassa viscosità, pronto all'uso, a basso ingiallimento. L'indurimento avviene per reazione di poliaddizione senza alcun fenomeno di ritiro. Fattori ambientali durante l'indurimento possono provocare imperfezioni del film polimerizzato quali schivature, rugosità superficiali, piccoli rigonfiamenti, che però non pregiudicano in alcun modo le caratteristiche chimico - fisiche del prodotto. Il materiale è impermeabile al vapore, all'acqua, ai combustibili, a lubrificanti e presenta inoltre una elevata resistenza chimica alle soluzioni basiche e debolmente acide. Per uso professionale.		Two-pack low-viscosity, transparent, ready-to-use formulation containing modified epoxy resins and special additives. Thanks to its particular low yellowing formulation, it makes transparent finishes possible. Hardening is achieved through a polyaddition reaction, without any shrinkage. During hardening, environmental factors can lead to imperfections in the polymerized film such as cissings, surface roughness, minor swelling; these do not in any way affect the product's chemical-physical properties. The material is impermeable to steam, water, fuels, lubricants and also offers high chemical resistance to basic and weakly acidic solutions. For professional use.		Formulación bicomponente con base de resinas epoxídicas modificadas y aditivos especiales, transparente, de baja viscosidad, lista para usar, de bajo índice de amarilleo. El endurecimiento se produce por reacción de poliadición exento de fenómenos de retracción. Los factores ambientales durante el endurecimiento pueden provocar imperfecciones de la película polimerizada, como cráteres, rugosidades superficiales, pequeñas convexidades, que en todo caso no afectan a las características químico-físicas del producto. El material es impermeable al vapor, al agua, a los combustibles, a lubricantes, y presenta además una elevada resistencia química a las soluciones básicas y débilmente ácidas. Para uso profesional.	
<b>Attrezzatura:</b> spatola dentata, rullo <b>Rapporto di catalisi:</b> (A:B) 65:35 <b>Diluizione:</b> pronto uso <b>Resa:</b> 1,1 kg/m <sup>2</sup> per mm di spessore <b>Colore:</b> incolore		<b>Equipment:</b> serrated spatula, roller <b>Mixing ration:</b> (A:B) 65:35 <b>Dilution:</b> ready to use <b>Coverage:</b> 1,1 kg/m <sup>2</sup> per mm of thickness <b>Color:</b> transparent		<b>Herramientas:</b> espátula dentada, rodillo <b>Relación de catalisis:</b> (A:B) 65:35 <b>Dilución:</b> listo para usar <b>Rendimiento:</b> 1,1 kg/m <sup>2</sup> per mm de espesor <b>Color:</b> incoloro	

tecniche	certificazioni	proprietà	tecnologie
TROWEL ROLLER		CARRIAGEABLE	





## acquatop fix

scheda  
tecnicadata  
sheetficha  
técnica

fissativo acrilico all'acqua alta penetrazione	<b>interno esterno</b>	water-based acrylic fixative, excellent penetrating properties	<b>indoor outdoor</b>	fijador acrílico al agua de alto poder penetrante	<b>interior exterior</b>
Fissativo acrilico all'acqua a base di resine acriliche particolari, non filmogeno a particelle estremamente fini, formulato per ottenere un'alta penetrazione su rasature cementizie anche sfarinanti e per uniformare gli assorbimenti. Ideale come fissativo per applicazioni su cemento nel ciclo Acquatop. Per uso professionale.		Water-based, non film-forming acrylic fixative containing extremely fine particles and special acrylic resins, formulated to achieve high penetration on cement-based skimming, even when chalky, and to ensure uniform absorption. Ideal as fixative for Acquatop application on cement. For professional use.		Fijador acrílico al agua a base de resinas acrílicas particulares, no filmógeno, de partículas extremadamente finas, formulado para obtener una alta penetración en morteros de enrasado de cemento, incluso con desintegración pulverulenta, y para uniformar las absorciones. Ideal como fijador para aplicaciones en cemento en el ciclo Acquatop. Para uso profesional.	
<b>Attrezzatura:</b> pennello, rullo, airless <b>Rapporto di catalisi:</b> (A:B) 89:11 <b>Diluizione:</b> acqua - max 50% <b>Resa (1 mano):</b> 7-8 m <sup>2</sup> /l - Per confezione (5 l): 60 m <sup>2</sup> <b>Colore:</b> incolore		<b>Equipment:</b> brush, roller, airless <b>Mixing ration:</b> (A:B) 89:11 <b>Dilution:</b> water - max 50% <b>Coverage</b> (1 coat): 7-8 m <sup>2</sup> /l - Per package (5 l): 60 m <sup>2</sup> <b>Color:</b> transparent		<b>Herramientas:</b> brocha, rodillo, pistola pulverizadora <b>Relación de catalisis:</b> (A:B) 89:11 <b>Dilución:</b> agua - max 50% <b>Rendimiento</b> (1 capa): 7-8 m <sup>2</sup> /l - Por envase (5 l): 60 m <sup>2</sup> <b>Color:</b> incoloro	

tecniche	certificazioni	proprietà	tecnologie
 WATER BASED  BRUSH  ROLLER  AIRLESS			

## acquatop primer

scheda  
tecnicadata  
sheetficha  
técnica

fondo monocomponente pigmentato	<b>interno esterno</b>	one-pack pigmented base coat	<b>indoor outdoor</b>	fondo monocomponente pigmentado	<b>interior exterior</b>
Fondo monocomponente pigmentato a base di resine acriliche in dispersione acquosa, additivato con polveri di quarzo. Caratterizzato da un ottimo potere di adesione. Ideale come primer aggrappante per i supporti sotto descritti e particolarmente indicato per il ciclo Acquatop. Per uso professionale.		Ready-to-use one-pack, pigmented acrylic resin-based base coat dispersed in water with quartz powder additives. Offers outstanding adhesion power. Ideal as primer to enhance adhesion on ceramics, bitumen sheaths, marble, stone and similar products. Particularly suitable for the Acquatop line. For professional use.		Fondo monocomponente pigmentado a base de resinas acrílicas en dispersión acuosa, listo para usar, aditivado con polvos de cuarzo, caracterizado por un excelente poder de adhesión, ideal como imprimación activadora de adhesión para cerámica, funda bituminosa, mármol, piedra y productos similares. Particularmente adecuado para ciclo Acquatop. Para uso profesional.	
<b>Attrezzatura:</b> pennello, rullo <b>Diluizione:</b> pronto uso <b>Resa (1 mano):</b> 7-8 m <sup>2</sup> /l - Per confezione (15 l): 120 m <sup>2</sup> <b>Colore:</b> bianco		<b>Equipment:</b> brush, roller <b>Dilution:</b> ready to use <b>Coverage</b> (1 coat): 7-8 m <sup>2</sup> /l - Per package (15 l): 120 m <sup>2</sup> <b>Color:</b> white		<b>Herramientas:</b> brocha, rodillo <b>Dilución:</b> listo para usar <b>Rendimiento</b> (1 capa): 7-8 m <sup>2</sup> /l - Por envase (15 l): 120 m <sup>2</sup> <b>Color:</b> blanco	

tecniche	certificazioni	proprietà	tecnologie
 WATER BASED  BRUSH  ROLLER  READY TO USE			

## acquatop cover



scheda  
tecnica



data  
sheet



ficha  
técnica



membrana líquida plastoelástica fibrada	<b>interno esterno</b>	fibre-reinforced, plasto-elastic liquid membrane	<b>indoor outdoor</b>	membrana líquida plastoelástica fibrada	<b>interior exterior</b>
Membrana líquida plastoelástica fibrada con alto poder rellentivo. Pedonable per tráfico de media intensidad. Idónea per impermeabilizar techos planos, balcones y terrazas. Su richiesta può essere formulato con pigmenti riflettenti ad alto índice de TSR, che riducono fino al 50% il riscaldamento delle superficies su cui viene applicato. Acqua Cover colore bianco garantisce una alta reflectancia (HR). Per uso profesional.		Fibre-reinforced, plasto-elastic liquid membrane with high filling power. Allows medium-intensity foot traffic. Suitable for waterproofing flat roofs, balconies and terraces. On request, it can be formulated with reflective, high TSR pigments, which reduce heating of the laying surfaces by up to 50%. Acqua Cover, in white color garantiza una alta reflectancia (HR). For professional use.		Membrana líquida plastoelástica fibrada con alto poder de relleno. Admite tráfico peatonal de mediana intensidad. Idónea para impermeabilizar techos planos, balcones y terrazas. puede formularse con pigmentos reflectantes de alto índice de TSR, que reducen hasta el 50% el calentamiento de las superficies sobre las que se aplica. Acqua Cover, in white color ensures high reflectance (HR). Para uso profesional.	
<b>Attrezzatura:</b> pennello, rullo <b>Diluizione:</b> acqua - pronto uso <b>Resa</b> (3 mani): 2 kg/m <sup>2</sup> - Per confezione (20 kg): 10 m <sup>2</sup> <b>Colore:</b> rosso (S5040-Y70R) - verde (5020-G) - rosso tegola (3030-Y50R) - tortora (4010-Y50R) - grigio (4502-Y) - bianco		<b>Equipment:</b> brush, roller <b>Dilution:</b> water - ready to use <b>Coverage</b> (3 mani): 2 kg/m <sup>2</sup> - Per package (20 kg): 10 m <sup>2</sup> <b>Color:</b> red (S5040-Y70R) - green (5020-G) - roofing tile red (3030-Y50R) - dove-grey (4010-Y50R) - grey (4502-Y) - white		<b>Herramientas:</b> brocha, rodillo <b>Dilución:</b> agua - listo para usar <b>Rendimiento</b> (3 mani): 2 kg/m <sup>2</sup> - Por envase (20 kg): 10 m <sup>2</sup> <b>Color:</b> rojo (S5040-Y70R) - verde (5020-G) - rojo tegola (3030-Y50R) - tortora (4010-Y50R) - gris (4502-Y) - blanco	

tecniche	certificazioni	proprietà	tecnologie

## acquatop walk



scheda  
tecnica



data  
sheet



ficha  
técnica



rivestimento mono- componente satinato	<b>interno esterno</b>	one-pack, satin-finish coating	<b>indoor outdoor</b>	revestimiento mono- componente satinado	<b>interior exterior</b>
Rivestimento monocomponente satinato a base di resina acrilica in emulsione acquosa, dotato di elevata adesione, flessibilità, resistenza chimica, meccanica, all'acqua e all'abrasione. Fortemente resistente alle radiazioni UV. Particolarmente idoneo come finitura protettiva per Acquatop Cover, migliorandone la pedonabilità, grazie alla sua resistenza meccanica. Può essere formulato con pigmenti riflettenti (reflect) ad alto índice de TSR ed applicato su pavimentazioni cementizie. Permette una pedonalità per tráfico ad elevata intensità. Per uso profesional.		One-pack, epoxy resin-based coating in aqueous emulsion. Produces a satin finish featuring high adhesion power, flexibility and superb resistance to chemicals, wear, water and abrasion. Highly resistant to UV radiation. Particularly suitable as protective topcoat for Acquatop Cover, improving walkability thanks to its mechanical resistance. Can be formulated with reflective, high TSR pigments. Allows high-intensity foot traffic. For professional use.		Revestimiento monocomponente satinado a base de resina acrílica en emulsión acuosa, dotado de alta capacidad de adhesión, flexibilidad, resistencia química, mecánica, al agua y a la abrasión. Fuertemente resistente a las radiaciones UVA. Particolarmente idóneo como acabado protector para Acquatop Cover, mejorando su transitabilidad, gracias a su resistencia mecánica. Puede formularse con pigmentos reflectantes (reflect) de alto índice de TSR. Permite una transitabilidad para tráfico de intensidad alta. Para uso profesional.	
<b>Attrezzatura:</b> pennello, rullo, airless <b>Diluizione:</b> acqua - pronto uso <b>Resa</b> (2 mani): 2,5-3 m <sup>2</sup> /l - Per confezione (15 l): 45 m <sup>2</sup> <b>Colore:</b> rosso (S5040-Y70R) - verde (5020-G) - rosso tegola (3030-Y50R) - tortora (4010-Y50R) - grigio (4502-Y) - bianco		<b>Equipment:</b> brush, roller, airless <b>Dilution:</b> water - ready to use <b>Coverage</b> (2 coats): 2,5-3 m <sup>2</sup> /l - Per package (15 l): 45 m <sup>2</sup> <b>Color:</b> red (S5040-Y70R) - green (5020-G) - roofing tile red (3030-Y50R) - dove-grey (4010-Y50R) - grey (4502-Y) - white		<b>Herramientas:</b> brocha, rodillo, pistola pulverizadora <b>Dilución:</b> agua - listo para usar <b>Rendimiento</b> (2 capas): 2,5-3 m <sup>2</sup> /l - Por envase (15 l): 45 m <sup>2</sup> <b>Color:</b> rojo (S5040-Y70R) - verde (5020-G) - rojo tegola (3030-Y50R) - tortora (4010-Y50R) - gris (4502-Y) - blanco	

tecniche	certificazioni	proprietà	tecnologie

## quarzo 06



Inerte quarzifero ottenuto da sabbie selezionate a granulometria controllata atto al conferimento di maggior spessore e resistenze meccaniche.

**Granulometria:** 0,06-0,5 mm

Quartz-based inert derived from selected sands with controlled particle size. It imparts greater thickness and mechanical resistance.

**Particle size:** 0.06-0.5 mm

Cuarzo inerte obtenido a partir de arenas seleccionadas con granulometria controlada diseñado para dar mayor espesor y resistencia mecánica.

**Granulometria:** 0,06-0,5 mm

## quarzo 04



Inerte quarzifero ottenuto da sabbie selezionate a granulometria controllata atto al conferimento di maggior spessore e resistenze meccaniche.

**Granulometria:** 0,1-1,5 mm

Quartz-based inert derived from selected sands with controlled particle size. It imparts greater thickness and mechanical resistance.

**Particle size:** 0,1-1,5 mm

Cuarzo inerte obtenido a partir de arenas seleccionadas con granulometria controlada diseñado para dar mayor espesor y resistencia mecánica.

**Granulometria:** 0,1-1,5 mm

## quarzo 02



Inerte quarzifero ottenuto da sabbie selezionate a granulometria controllata atto al conferimento di maggior spessore e resistenze meccaniche.

**Granulometria:** 0,3-0,9 mm

Quartz-based inert derived from selected sands with controlled particle size. It imparts greater thickness and mechanical resistance.

**Particle size:** 0,3-0,9 mm

Cuarzo inerte obtenido a partir de arenas seleccionadas con granulometria controlada diseñado para dar mayor espesor y resistencia mecánica.

**Granulometria:** 0,3-0,9 mm

## corindone bianco



Carica in polvere per Epoplast, per conferire alla pavimentazione un effetto decorativo e di maggior resistenza superficiale

Powder extender for Epoplast. It gives the flooring a decorative look and greater surface resistance.

Masilla en polvo para Epoplast, para dar al pavimento un efecto decorativo y una mayor resistencia superficial

## corindone bruno



Carica in polvere per Epoplast, per conferire alla pavimentazione un effetto decorativo e di maggior resistenza superficiale

Powder extender for Epoplast. It gives the flooring a decorative look and greater surface resistance.

Masilla en polvo para Epoplast, para dar al pavimento un efecto decorativo y una mayor resistencia superficial

## aerosil 200

---



Silicie addensante per sistemi resinosi

Silica-based thickener for resinous systems.

Espesante de silicio para sistemas de resinas

## microfibra 80

---



Additivo per resine epossidiche e poliuretatiche, per finiture antiskid

Additive for epoxy and polyurethane resins, for antiskid finishes.

Aditivo para resinas epoxi y poliuretano, para acabados antideslizantes

## cips colorate

---



Cariche decorative per Epoplast

Decorative extenders for Epoplast.

Cariche decorativas para Epoplast

## perline vetro

---



Additivo per resine epossidiche e poliuretatiche, per finiture antiskid

Additive for epoxy and polyurethane resins, for antiskid finishes.

Aditivo para resinas epoxi y poliuretano, para acabados antiskid



## polybeton ls

scheda  
tecnicadata  
sheetficha  
técnica

rivestimento elastico tricomponente poliuretano	<b>interno esterno</b>	elastic, three-pack, polyurethane coating	<b>indoor outdoor</b>	revestimiento elástico tricomponente poliuretánico	<b>interior exterior</b>
Rivestimento autolivellante elastico tricomponente poliuretano per la realizzazione di malte autolivellanti elastoplastiche pedonabili, utilizzabile anche a rullo come rivestimento a basso spessore elastico. Spessori consigliati fino a 3 mm. Colorato, indicato per pavimenti soggetti a carichi pesanti e sollecitazioni meccaniche e chimiche. Per uso professionale.		Three-pack elastic, polyurethane coating for the production of elastic-plastic self-levelling mortars that can be walked on; can also be applied by roller as a coating with low elastic thickness. Recommended thickness: up to 3 mm. Coloured, suitable for floors subject to heavy loads and mechanical and chemical stresses. For professional use.		Revestimiento autonivelante elástico tricomponente poliuretánico para la realización de morteros autonivelantes elastoplásticos válidos para tránsito peatonal, utilizable también con rodillo como revestimiento de bajo espesor elástico. Espesores aconsejados hasta 3 mm. De color, indicado para suelos sujetos a cargas pesadas y esfuerzos mecánicos y químicos. Para uso profesional.	
<b>Attrezzatura:</b> spatola dentata, rullo frangi-bolle <b>Rapporto di catalisi:</b> (A:B:C) 2,74:2,22:11,5 <b>Diluizione:</b> pronto uso <b>Resa:</b> 2 kg/m <sup>2</sup> per mm di spessore <b>Colore:</b> colorato		<b>Equipment:</b> serrated spatula, bubble-buster roller <b>Mixing ratio:</b> (A:B:C) 2,74:2,22:11,5 <b>Dilution:</b> ready to use <b>Coverage:</b> 2 kg/m <sup>2</sup> per mm of thickness <b>Color:</b> colored		<b>Herramientas:</b> Espátula dentada y rodillo antiburbujas para aplicación de espesor <b>Relación de catálisis:</b> (A:B:C) 2,74:2,22:11,5 <b>Dilución:</b> listo para usar <b>Rendimiento:</b> 2 kg/m <sup>2</sup> per mm de espesor <b>Color:</b> colorido	

tecniche	certificazioni	proprietà	tecnologie
 SOLVENT BASED  TROWEL  ROLLER		 WALKABLE	

## polybeton ht

scheda  
tecnicadata  
sheetficha  
técnica

rivestimento elastico tricomponente poliuretano	<b>interno esterno</b>	three-pack, elastic, polyurethane coating	<b>indoor outdoor</b>	revestimiento elástico tricomponente poliuretánico	<b>interior exterior</b>
Rivestimento autolivellante elastico tricomponente poliuretano per la realizzazione di malte autolivellanti elastoplastiche pedonabili, utilizzabile anche a rullo come rivestimento spessore consigliato 6/7 mm elastico. Colorato, indicato per pavimenti soggetti a carichi pesanti e sollecitazioni meccaniche e chimiche. Per uso professionale.		Three-pack elastic, polyurethane coating for the production of elastic-plastic self-levelling mortars that can be walked on; it can also be applied by roller, recommended thickness 6/7 mm. Coloured, suitable for floors subject to heavy loads and mechanical and chemical stresses. For professional use.		Revestimiento autonivelante elástico tricomponente poliuretánico para la realización de morteros autonivelantes elastoplásticos válidos para tránsito peatonal, utilizable también con rodillo como revestimiento, espesor recomendado 6/7mm. De color, indicado para suelos sujetos a cargas pesadas y esfuerzos mecánicos y químicos. Para uso profesional.	
<b>Attrezzatura:</b> spatola dentata, rullo frangi-bolle <b>Rapporto di catalisi:</b> (A:B:C) 2,74:2,22:23 <b>Diluizione:</b> pronto uso <b>Resa:</b> 2 kg/m <sup>2</sup> per mm di spessore <b>Colore:</b> colorato		<b>Equipment:</b> serrated spatula, bubble-buster roller <b>Mixing ratio:</b> (A:B:C) 2,74:2,22:23 <b>Dilution:</b> ready to use <b>Coverage:</b> 2 kg/m <sup>2</sup> per mm of thickness <b>Color:</b> colored		<b>Herramientas:</b> espátula dentada y rodillo antiburbujas para aplicación de espesor <b>Proporción de mezcla:</b> (A:B:C) 2,74:2,22:23 <b>Dilución:</b> listo para usar <b>Rendimiento:</b> 2 kg/m <sup>2</sup> per mm de espesor <b>Color:</b> colorido	

tecniche	certificazioni	proprietà	tecnologie
 SOLVENT BASED  TROWEL  ROLLER		 WALKABLE	

# polyfast p



scheda  
tecnica



data  
sheet



ficha  
técnica

rivestimento elastico poliuretano	<b>interno esterno</b>	elastic polyurethane coating	<b>indoor outdoor</b>	revestimiento elástico poliuretánico	<b>interior exterior</b>
Rivestimento elastico, a base di resine poliureiche. Formulato con isocianati aromatici e particolari diammine a diversificato peso molecolare. Per la sua elevata resistenza è adatto anche per impermeabilizzazione di parcheggi auto. Per uso professionale.		Elastic coating, based on polyurea resins. Formulated with aromatic isocyanates and particular diamines of different molecular weights. Due to its high resistance it is also suitable for waterproofing car parks. For professional use.		Revestimiento elástico, a base de resinas poliureicas. Formulada con isocianatos aromáticos y diaminas específicas de distintos pesos moleculares. Por su alta resistencia también es adecuado para la impermeabilización de aparcamientos. Para uso profesional.	
<b>Attrezzatura:</b> airless tipo bi-mixer ad alta pressione <b>Rapporto di catalisi:</b> (A:B) 50:50 <b>Diluizione:</b> pronto uso <b>Resa:</b> 1 kg/m <sup>2</sup> per mm di spessore <b>Colore:</b> incolore		<b>Equipment:</b> high pressure airless, bi-mixer type <b>Mixing ration:</b> (A:B) 50:50 <b>Dilution:</b> ready to use <b>Coverage:</b> 1 kg/m <sup>2</sup> per mm of thickness <b>Color:</b> transparent		<b>Herramientas:</b> Pistola pulverizadora tipo bi-mixer de alta presión <b>Relación de catalisis:</b> (A:B) 50:50 <b>Dilución:</b> listo para usar <b>Rendimiento:</b> 1 kg/m <sup>2</sup> per mm de espesor <b>Color:</b> incoloro	

tecniche			certificazioni			proprietà			tecnologie			

# polyfast ib

rivestimento elastico poliuretano	<b>esterno</b>	elastic polyurethane coating	<b>outdoor</b>	revestimiento elástico poliuretánico	<b>exterior</b>
Rivestimento bicomponente elastico, a base di resine poliureiche. Poliurea formulata con isocianati aromatici e particolari diammine a diversificato peso molecolare. Per uso professionale.		Elastic coating, based on polyurea resins formulated with aromatic isocyanates and particular diamines of different molecular weights. For professional use.		Revestimiento bicomponente elástico, a base de resinas poliureicas formulada con isocianatos aromáticos y diaminas específicas de distintos pesos moleculares. Para uso profesional.	
<b>Attrezzatura:</b> airless tipo bi-mixer ad alta pressione <b>Rapporto di catalisi:</b> (A:B) 50:50 <b>Diluizione:</b> pronto uso <b>Resa:</b> 1 kg/m <sup>2</sup> per mm di spessore <b>Colore:</b> incolore		<b>Equipment:</b> high pressure airless, bi-mixer type <b>Mixing ration:</b> (A:B) 50:50 <b>Dilution:</b> ready to use <b>Coverage:</b> 1 kg/m <sup>2</sup> per mm of thickness <b>Color:</b> transparent		<b>Herramientas:</b> Pistola pulverizadora tipo bi-mixer de alta presión <b>Proporción de mezcla:</b> (A:B) 50:50 <b>Dilución:</b> listo para usar <b>Rendimiento:</b> 1 kg/m <sup>2</sup> per mm de espesor <b>Color:</b> incoloro	

tecniche			certificazioni			proprietà			tecnologie		

## bandella di rame



Reticolo in rame per ciclo autolivellante antistatico

Mesh of copper strips for antistatic self-levelling applications

Rejilla de cobre para ciclo autonivelante antiestático

**Dimensioni rotolo:** 10 mm x 16,5 m

**Roll size:** 10 mm x 16,5 m

**Tamaño de rollo:** 10 mm x 16,5 m

## tessuto di vetro



Rete tessuta in fibra di vetro per l'armatura delle rasature epossidiche, all'interno ed all'esterno.

Glass fibre mesh to reinforce epoxy skim coats. For interior and exterior

Malla tejida de fibra de vidrio para el refuerzo del alisado epoxi, tanto en el interior como en el exterior.

**Peso:** 80 g/m<sup>2</sup>

**Weight:** 80 g/m<sup>2</sup>

**Peso:** 80 g/m<sup>2</sup>





IL NETWORK DEL COLORE SU MISURA

**you**  
**sistema tir**



# linee prodotti

macchine tintometriche

accessori

coloranti concentrati

prodotti a tintometro

**u color**  
**ntometrico**

## tintometro manuale



12 o 20 canestri	12 o 20 canisters	12 o 20 botes
<ul style="list-style-type: none"> <li>▶ Manuale</li> <li>▶ Ideale per coloranti all'acqua e a solvente</li> <li>▶ Ergonomico e funzionale</li> <li>▶ Maneggevole durante il dosaggio</li> <li>▶ Facile da utilizzare, anche per operatori inesperti</li> <li>▶ Canestri resistenti in poli ossido metilene</li> <li>▶ Valvole in ceramica resistenti all'abrasione</li> <li>▶ Sistema antigocciolamento automatico (mantiene pulita l'area di lavoro)</li> </ul>	<ul style="list-style-type: none"> <li>▶ Manual</li> <li>▶ Ideal for water and solvent based colourants</li> <li>▶ Ergonomic and functional</li> <li>▶ Easy to use during dosage</li> <li>▶ Easy to use, also for inexperienced operators</li> <li>▶ Resistant canisters in poly ethylene oxide</li> <li>▶ Abrasion-resistant ceramic valves</li> <li>▶ Automatic anti-drip system (keeps the work area clean)</li> </ul>	<ul style="list-style-type: none"> <li>▶ Manual</li> <li>▶ Ideal para tintes a base de agua y solventes</li> <li>▶ Ergonómico y funcional</li> <li>▶ Práctico durante la dosificación</li> <li>▶ Fácil de usar, incluso para operadores sin experiencia</li> <li>▶ Cestas de polioxido de metileno resistentes</li> <li>▶ Válvulas de cerámica resistentes a la abrasión</li> <li>▶ Sistema automático antigoteo (mantiene limpia el área de trabajo)</li> </ul>
<b>Numero Canestri:</b> 12 o 20 <b>Settore di produzione:</b> acqua e solvente. Ideale per rivendite medio-piccole con produzione non continuativa <b>Dimensioni:</b> 121x110 cm	<b>Number of canisters:</b> 12 o 20 <b>Production sector:</b> water and solvent. Ideal for medium-small retail with non-continuous production <b>Dimensions:</b> 121x110 cm	<b>Numero de botes:</b> 12 o 20 <b>Sector productivo:</b> agua y solvente Ideal para reventas pequeñas y medianas con producción discontinua <b>Medidas:</b> 121x110 cm

## tintometro a4b



24 canestri	24 canisters	24 botes
<ul style="list-style-type: none"> <li>▶ Automatico Sequenziale</li> <li>▶ Dotato di piano girevole, a 24 canestri</li> <li>▶ Elettronica semplificata di ultima generazione</li> <li>▶ Altezza di soli 1,3 m (quindi facile da utilizzare)</li> <li>▶ Facilità di riempimento dei coloranti</li> <li>▶ Facile accesso a tutti i controlli</li> <li>▶ Compreso di braccio di supporto per monitor computer</li> <li>▶ Compreso software Datacolor Paint EFB</li> <li>▶ Sgabello elevatore per latta automatico</li> <li>▶ Non richiede spurgo giornaliero degli ugelli</li> </ul>	<ul style="list-style-type: none"> <li>▶ Automatic sequential dispensing</li> <li>▶ With two-way turntable, 24 canisters</li> <li>▶ Latest generation of simplified electronics</li> <li>▶ Height only 1.3 m (easy to use)</li> <li>▶ Easy refilling of dyes</li> <li>▶ Easy access to all controls</li> <li>▶ Support arm for PC monitor included</li> <li>▶ Software Datacolor Paint EFB included</li> <li>▶ Automatic can lift</li> <li>▶ nozzle cleaning not required daily</li> </ul>	<ul style="list-style-type: none"> <li>▶ Secuencial automático</li> <li>▶ Equipado con tapa giratoria, con 24 cestas</li> <li>▶ Electrónica simplificada de última generación</li> <li>▶ Altura de solo 1,3m (por lo tanto, fácil de usar)</li> <li>▶ Fácil llenado de tintes</li> <li>▶ Fácil acceso a todos los controles</li> <li>▶ Incluye brazo de soporte para monitor de computadora</li> <li>▶ Incluye el software Datacolor Paint EFB</li> <li>▶ Taburete elevador para estaño automático</li> <li>▶ No requiere sangrado diario de las boquillas</li> </ul>
<b>Numero Canestri:</b> 24 <b>Settore di produzione:</b> acqua Ideale per negozi e centri del colore di medie dimensioni con produzione media di 20-30 confezioni al giorno <b>Dimensioni:</b> 90x100x133,5 cm	<b>Number of canisters:</b> 24 <b>Production sector:</b> water Ideal for medium sized retail and paint shops with an average production of 20-30 containers a day. <b>Dimensions:</b> 90x100x133.5 cm	<b>Numero de botes:</b> 24 <b>Sector productivo:</b> agua Ideal para medianas tiendas y centros de la Gama de colores con una producción media de 20-30 envases por día <b>Medidas:</b> 90x100x133,5 cm

## tintometro elettronico d300



20 canestri	20 canisters	20 botes
<ul style="list-style-type: none"> <li>▶ Automatico Simultaneo</li> <li>▶ Nuova tecnologia di pompaggio a pistone brevettata</li> <li>▶ Ottimo rapporto qualità-quantità/prezzo</li> <li>▶ Bassi costi di manutenzione</li> <li>▶ Altezza di soli 1,3 m (quindi facile da utilizzare)</li> <li>▶ Alta velocità di erogazione</li> <li>▶ Sistema brevettato di umidificazione automatico</li> <li>▶ Ridotta possibilità di essiccazione del colorante</li> <li>▶ Configurabile con canestri di 4 o 6 litri</li> </ul>	<ul style="list-style-type: none"> <li>▶ Automatic simultaneous dispensing</li> <li>▶ New patented piston pump technology</li> <li>▶ Excellent quality-quantity / price ratio</li> <li>▶ Low maintenance costs</li> <li>▶ Height only 1.3 m (easy to use)</li> <li>▶ High speed dispensing</li> <li>▶ Patented automatic humidification system</li> <li>▶ Reduced possibility of drying of dyes</li> <li>▶ Set up with 4 or 6 litre canisters</li> </ul>	<ul style="list-style-type: none"> <li>▶ Automático simultáneo</li> <li>▶ Nueva tecnología de bombeo de pistón patentada</li> <li>▶ Excelente relación calidad-cantidad / precio</li> <li>▶ Bajos costos de mantenimiento</li> <li>▶ Altura de solo 1,3 m (por lo tanto, fácil de usar)</li> <li>▶ Alta velocidad de dispensación</li> <li>▶ Sistema de humidificación automático patentado</li> <li>▶ Posibilidad reducida de secado del tinte</li> <li>▶ Configurable con bidones de 4 o 6 litros</li> <li>▶ Incluye el software Datacolor Paint Color Cardmatch</li> </ul>
<p><b>Numero Canestri:</b> 20  <b>Settore di produzione:</b> acqua            Ideale per negozi e centri del colore di medie dimensioni con produzione di 30/50 confezioni al giorno  <b>Dimensioni:</b> 102x94x136 cm</p>	<p><b>Number of canisters:</b> 20  <b>Production sector:</b> water            Ideal for medium sized retail and paint shops with a production of 30/50 containers a day  <b>Dimensions:</b> 102x94x136 cm</p>	<p><b>Numero de botes:</b> 20  <b>Sector productivo:</b> agua            Ideal para medianas tiendas y centros de la Gama de colores con producción de 30/50 paquetes por día  <b>Dimensiones:</b> 102x94x136 cm</p>

## tintometro ha480



20 canestri	20 canisters	20 botes
<ul style="list-style-type: none"> <li>▶ Automatico Sequenziale</li> <li>▶ Performante e affidabile</li> <li>▶ Design di qualità</li> <li>▶ Zero spreco di colorante</li> <li>▶ Manutenzione minima</li> <li>▶ Un dispensatore sempre pronto</li> <li>▶ Pompa a pistone per svuotamento autonomo</li> <li>▶ Compreso software Datacolor Paint Color Cardmatch</li> <li>▶ Non richiede spurgo giornaliero degli ugelli</li> </ul>	<ul style="list-style-type: none"> <li>▶ Automatic sequential dispensing</li> <li>▶ High performance and trustworthy</li> <li>▶ Quality design</li> <li>▶ Zero waste of colourants</li> <li>▶ Minimal maintenance</li> <li>▶ Dispenser always ready</li> <li>▶ Piston pump for automatic emptying</li> <li>▶ Software Datacolor Paint Color Cardmatch included</li> <li>▶ Nozzle cleaning not required daily</li> </ul>	<ul style="list-style-type: none"> <li>▶ Secuencial automático</li> <li>▶ Desempeño y confiable</li> <li>▶ Diseño de calidad</li> <li>▶ Cero desperdicio de tinte</li> <li>▶ Mantenimiento mínimo</li> <li>▶ Un dispensador siempre listo</li> <li>▶ Bomba de pistón para vaciado autónomo</li> <li>▶ Incluye el software Datacolor Paint Color Cardmatch</li> <li>▶ No requiere sangrado diario de las boquillas</li> </ul>
<p><b>Numero Canestri:</b> 20  <b>Settore di produzione:</b> acqua e solvente            Ideale per centri bricolage, depositi, colorifici, punti vendita di medio-grandi dimensioni con produzione di oltre 50 confezioni al giorno. Ideale per coprire l'intera gamma prodotti lvas  <b>Dimensioni:</b> 88x96x151 cm</p>	<p><b>Number of canisters:</b> 20  <b>Production sector:</b> water and solvent            Ideal for medium-large sized DIY outlets, retailers, paint shops, points of sale with a production of over 50 containers a day. Ideal to cover the complete lvas range of products  <b>Dimensions:</b> 88x96x151 cm</p>	<p><b>Numero de botes:</b> 20  <b>Sector productivo:</b> agua y solvente            Ideal para centros de bricolaje, almacenes, talleres de pintura, tiendas de tamaño mediano-grande con producción de más de 50 paquetes por día. Ideal para cubrir toda la gama de productos lvas  <b>Dimensiones:</b> 88x96x151 cm</p>

## tintometro d600 minimodula



elettronico simultaneo a 20 canestri	simultaneous electronic 20 canisters	electrónico simultáneo a 20 botes
<ul style="list-style-type: none"> <li>▶ Automatico Simultaneo</li> <li>▶ Testata interna</li> <li>▶ Modula con testa di erogazione espandibile fino a 20 ugelli</li> <li>▶ Estetica compatta</li> <li>▶ Massima ergonomicità e funzionalità</li> <li>▶ Sistema Autocap che evita l'essiccazione del colorante</li> <li>▶ Elettronica di ultima generazione</li> <li>▶ Dispensazione veloce, precisa e ripetibile</li> <li>▶ Compreso software Datacolor Paint Color Cardmatch</li> </ul>	<ul style="list-style-type: none"> <li>▶ Automatic simultaneous dispensing</li> <li>▶ Internal Head</li> <li>▶ Module with dispensing head expandable up to 20 nozzles</li> <li>▶ Compact design</li> <li>▶ Maximum flow and workability</li> <li>▶ Autocap System to avoid drying of dyes</li> <li>▶ Electronics of latest generation</li> <li>▶ Fast, precise and repeatable dispensing</li> <li>▶ Software Datacolor Paint Color Cardmatch included</li> </ul>	<ul style="list-style-type: none"> <li>▶ Automático simultáneo</li> <li>▶ Módulo con cabezal de salida ampliable hasta 20 boquillas</li> <li>▶ Estética compacta</li> <li>▶ Máxima ergonomía y funcionalidad</li> <li>▶ Sistema Autocap que evita que el tinte se seque</li> <li>▶ Electrónica de última generación</li> <li>▶ Dispensación rápida, precisa y repetible</li> <li>▶ Incluye el software Datacolor Paint Color Cardmatch</li> </ul>
<p><b>Numero Canestri:</b> 20  <b>Settore di produzione:</b> acqua            Ideale per centri bricolage, depositi, colorifici, punti vendita di medio-grandi dimensioni con produzione di oltre 50 confezioni al giorno            Ideale per coprire l'intera gamma prodotti lvas all'acqua  <b>Dimensioni:</b> 140x88x119 cm</p>	<p><b>Number of canisters:</b> 20  <b>Production sector:</b> water            Ideal for medium-large sized DIY outlets, retailers, paint shops and points of sale with production of over 50 containers a day.            Ideal to cover the complete lvas water-based range of products  <b>Dimensions:</b> 140x88x119 cm</p>	<p><b>Numero de botes:</b> 20  <b>Sector productivo:</b> agua            Ideal para centros de bricolaje, almacenes, talleres de pintura, tiendas de tamaño mediano-grande con producción de más de 50 paquetes por día.            Ideal para cubrir toda la gama de productos lvas all'agua  <b>Medidas:</b> 140x88x119 cm</p>

## tintometro elettronico d700



20 canestri testata esterna	external head 20 canisters	20 botas cabecera exterior
<ul style="list-style-type: none"> <li>▶ Automatico Simultaneo</li> <li>▶ Testata esterna</li> <li>▶ Top di gamma tra le macchine tintometriche sul mercato</li> <li>▶ Performance ottimizzata al più alto livello</li> <li>▶ Massima velocità di erogazione</li> <li>▶ Sistema Autocap che evita l'essiccazione del colorante</li> <li>▶ Precisione e ripetibilità delle tinte estremamente elevate</li> <li>▶ Modula con testa di erogazione a 20 ugelli</li> <li>▶ Pompe ad ingranaggi</li> <li>▶ Tecnologia di ultima generazione</li> <li>▶ Estetica compatta</li> <li>▶ Massima varietà di tinte erogabili</li> </ul>	<ul style="list-style-type: none"> <li>▶ Automatic simultaneous dispensing</li> <li>▶ External head</li> <li>▶ Top of the range of tinting machines on the market</li> <li>▶ Optimized performance at the highest level</li> <li>▶ Maximum flow speed</li> <li>▶ Autocap system to avoid drying of dyes</li> <li>▶ Precision and extremely high colour reproduction</li> <li>▶ Module with dispensing head 20 nozzles</li> <li>▶ Gear pump technology</li> <li>▶ Latest generation technology</li> <li>▶ Compact design Massima varietà di tinte erogabili</li> </ul>	<ul style="list-style-type: none"> <li>▶ Automático simultáneo</li> <li>▶ Top de gama entre las máquinas de tintado del mercado</li> <li>▶ Rendimiento optimizado al más alto nivel</li> <li>▶ Velocidad máxima de dispensación</li> <li>▶ Sistema Autocap que evita que el tinte se seque</li> <li>▶ Precisión y repetibilidad de colores extremadamente altas</li> <li>▶ Módulo con cabezal dispensador de 20 boquillas</li> <li>▶ Bombas de engranajes</li> <li>▶ Tecnología de última generación</li> <li>▶ Estética compacta</li> <li>▶ Máxima variedad de colores que se pueden dispensar</li> <li>▶ Incluye el software Datacolor Paint Color Cardmatch</li> <li>▶ Incluyendo 3 transportadores de rodillos</li> </ul>
<p><b>Numero Canestri:</b> 20  <b>Settore di produzione:</b> acqua            Ideale per centri professionali di grandi dimensioni, alta specializzazione con produzione oltre le 100 confezioni al giorno. Ideale per coprire l'intera gamma prodotti lvas  <b>Dimensioni:</b> 181x110x120 cm</p>	<p><b>Number of canisters:</b> 20  <b>Production sector:</b> water            Ideal for large sized professional centres, highly specialised with a production of over 100 containers a day.            Ideal to cover the complete lvas range of products  <b>Dimensions:</b> 181x110x120 cm</p>	<p><b>Numero de botes:</b> 20  <b>Sector productivo:</b> agua            Ideal para grandes centros profesionales, altamente especializados con producción superior a 100 envases al día.            Ideal para cubrir toda la gama de productos lvas  <b>Medidas:</b> 181x110x120 cm</p>

## tintometro elettronico d700



32 canestri testata esterna	external head 32 canisters	32 botas cabecera exterior
<ul style="list-style-type: none"> <li>▶ Automatico Simultaneo</li> <li>▶ Testata esterna</li> <li>▶ Top di gamma tra le macchine tintometriche sul mercato</li> <li>▶ Performance ottimizzata al più alto livello</li> <li>▶ Massima velocità di erogazione</li> <li>▶ Precisione e ripetibilità delle tinte estremamente elevate</li> <li>▶ Modula con testa di erogazione a 32 ugelli</li> <li>▶ Pompe ad ingranaggi</li> <li>▶ Tecnologia di ultima generazione</li> <li>▶ Estetica compatta</li> <li>▶ Massima varietà di tinte erogabili</li> </ul>	<ul style="list-style-type: none"> <li>▶ Automatic simultaneous dispensing</li> <li>▶ External head</li> <li>▶ Top of the range tinting machines on the market</li> <li>▶ Optimized performance at the highest level</li> <li>▶ Maximum flow speed</li> <li>▶ Precision and extremely high colour reproduction</li> <li>▶ Module with dispensing head 32 nozzles</li> <li>▶ Gear pump technology</li> <li>▶ Latest generation technology</li> <li>▶ Compact design</li> <li>▶ Maximum variety of dispensed colours</li> </ul>	<ul style="list-style-type: none"> <li>▶ Automático simultáneo</li> <li>▶ Top de gama entre las máquinas de tinado del mercado</li> <li>▶ Rendimiento optimizado al más alto nivel</li> <li>▶ Velocidad máxima de dispensación</li> <li>▶ Precisión y repetibilidad de colores extremadamente altas</li> <li>▶ Modula con cabezal dispensador de 32 boquillas</li> <li>▶ Bombas de engranajes</li> <li>▶ Tecnología de última generación</li> <li>▶ Estética compacta</li> <li>▶ Máxima variedad de colores que se pueden dispensar</li> <li>▶ Incluye el software Datacolor Paint Color Cardmatch</li> <li>▶ Incluyendo 4 transportadores de rodillos</li> </ul>
<p><b>Numero Canestri:</b> 32</p> <p><b>Settore di produzione:</b> acqua e solvente. Ideale per centri professionali di grandi dimensioni, alta specializzazione con produzione oltre le 100 confezioni al giorno. Ideale per coprire l'intera gamma prodotti Ivas</p> <p><b>Dimensioni:</b> 222x110x120 cm</p>	<p><b>Number of canisters:</b> 32</p> <p><b>Production sector:</b> water e solvent Ideal for large sized professional centres, highly specialised with a production of over 100 containers a day. Ideal to cover the complete Ivas range of products</p> <p><b>Dimensions:</b> 222x110x120 cm</p>	<p><b>Numero de botes:</b> 32</p> <p><b>Sector productivo:</b> agua y solvente Ideal para grandes centros profesionales, altamente especializados con producción superior a 100 envases al día. Ideal para cubrir toda la gama de productos Ivas</p> <p><b>Dimensiones:</b> 222x110x120 cm</p>

## mixer glos



<p>Agitatore a colonna professionale che viene posizionato direttamente sul fianco del tintometro per la miscelazione in linea e che permette una miscelazione a bassa velocità senza alterare la struttura di rivestimenti, quarzi lavabili, ecc.</p>	<p>Professional column mixer placed directly at the side of the tinting machine for in-line mixing, allowing low speed mixing without altering the structure of paints, washable quartz, etc.</p>	<p>Agitador de columna profesional que se coloca directamente en el lateral del tintómetro para mezclar en línea y que permite mezclar a baja velocidad sin alterar la estructura de recubrimientos, cuarzo lavable, etc.</p>
--	---	---



## agitatore manuale giroscopico



Agitatore manuale Giroscopico con porta tri-direzionale a scorrimento interno. Chiusura manuale.	Manual gyroscope mixer with three-directional sliding door. Manual closure.	Agitador manual Giroscopio con puerta tri-direccional de deslizamiento interno. Cierre manual.
<b>Capacità di carico:</b> 40 kg <b>Dimensioni:</b> 83x93x117,5 cm	<b>Weight capacity:</b> 40 kg <b>Dimensions:</b> 83x93x117,5 cm	<b>Capacità di carico:</b> 40 kg <b>Medidas:</b> 83x93x117,5 cm

## agitatore elettronico giroscopico



L'Agitatore Elettronico Giroscopico è un miscelatore automatico a 3 velocità. Idoneo alla miscelazione di tutti i tipi di vernice per esterni ed interni.	The electronic gyroscope stirrer is an automatic 3-speed mixer. Suitable for mixing all types of paint for exterior and interior use.	El agitador electrónico giroscópico es un mezclador biaxial automático de 3 velocidades. Apto para mezclar todo tipo de pintura para exterior e interior.
Testata interna <b>Piatto di carico:</b> estraibile <b>Capacità di carico:</b> 40 kg (h. fino a 49 cm) <b>Diametro massimo del contenitore:</b> 38 cm <b>Dimensioni:</b> 104x86x80 cm	Internal head <b>Loaded plate:</b> removable <b>Load capacity:</b> 40 kg (h. to 49 cm) <b>Maximum diameter of the container:</b> 38 cm <b>Dimensions:</b> 100x88x102 cm	Cabeza interna <b>Capacidad de carga:</b> 40 kg (h. hasta 49 cm) <b>Diámetro máximo del recipiente:</b> 38 cm. <b>Medidas:</b> 104x86x80 cm.

## software datacolor paint efb

<b>Livello 1:</b> Gestione formule delle collezioni IVAS e dei codici colori internazionali (NCS Index, RAL Design e RAL Classic)	<b>Level 1:</b> Formula management of the IVAS collections and international colour codes (NCS Index, RAL Design e RAL Classic)	<b>Nivel 1:</b> Gestión de fórmulas de colecciones IVAS y códigos de colores internacionales (NCS Index, RAL Design y RAL Classic)
---	---	--

## software datacolor paint color cardmatch

<b>Livello 1:</b> Gestione formule delle collezioni IVAS e dei codici colori internazionali (NCS Index, RAL Design e RAL Classic)	<b>Level 1:</b> Formula management of the IVAS collections and international colour codes (NCS Index, RAL Design e RAL Classic)	<b>Nivel 1:</b> Gestión de fórmulas de colecciones IVAS y códigos de colores internacionales (NCS Index, RAL Design y RAL Classic)
<b>Livello 2:</b> Oltre al livello 1, grazie alle caratterizzazioni colore personalizzate IVAS ed al motore di calcolo presente nel software aggiunge la possibilità di formulare tutte le tinte delle cartelle colore presenti sul mercato.	<b>Level 2:</b> In addition to level 1, thanks to the composition of the customised IVAS colours and the calculation engine in the software, there is the added possibility to formulate all the colours of the colour cards on the market.	<b>Nivel 2:</b> Además del nivel 1, gracias a las características de colores personalizados de IVAS y al motor de cálculo presente en el software, agrega la posibilidad de formular todos los colores de las gamas de colores del mercado.

## software per spettrofotometro

<b>Livello 1:</b> Gestione formule delle collezioni IVAS e dei codici colori internazionali (NCS Index, RAL Design e RAL Classic)	<b>Level 1:</b> Formula management of the IVAS collections and international colour codes (NCS Index, RAL Design e RAL Classic)	<b>Nivel 1:</b> Gestión de fórmulas de colecciones IVAS y códigos de colores internacionales (NCS Index, RAL Design y RAL Classic)
<b>Livello 2:</b> Grazie alle caratterizzazioni colore personalizzate IVAS ed al motore di calcolo presente nel software aggiunge la possibilità di formulare tutte le tinte delle cartelle colore presenti sul mercato	<b>Level 2:</b> In addition to level 1, thanks to the composition of the customised IVAS colours and the calculation engine in the software, there is the added possibility to instantly formulate and dispense any customer colour sample.	<b>Nivel 2:</b> Además del nivel 1, gracias a las características de colores personalizados de IVAS y al motor de cálculo presente en el software, agrega la posibilidad de formular todos los colores de las gamas de colores del mercado.
<b>Livello 3:</b> Oltre al livello 1 e 2, attraverso l'utilizzo dello spettrofotometro Datacolor D20 aggiunge la possibilità di caratterizzare ed erogare istantaneamente qualsiasi campione colore del cliente.	<b>Level 3:</b> In addition to level 1 and 2, by using the Datacolor D20 spectrophotometer you have the possibility to	<b>Nivel 3:</b> Además de los niveles 1 y 2, mediante el uso del espectrofotómetro Datacolor D20 agrega la posibilidad de caracterizar y dispensar instantáneamente la muestra de Gama de colores de cualquier cliente.

## spettrofotometro datacolor d20



La geometria a sfera di Datacolor D20 consente una misura precisa del colore su campioni lisci e con rilievi. La determinazione della lucentezza del campione, combinata con la compensazione della lucentezza nel software, consente una formulazione del colore visivamente perfetta. Lo strumento portatile consente di misurare qualsiasi campione in qualsiasi luogo, nel punto vendita o presso la sede di lavoro del vostro cliente.

**Peso:** 1,25 kg  
**Dimensioni:** 9,9x9x23,5 cm  
**Display:** LCD 240x320

The sphere geometry of Datacolor D20 allows precise colour measurement on smooth and textured samples. The characterisation of the gloss of the sample, combined with the gloss compensation in the software, allows a visually perfect colour formulation.

The portable tool allows you to measure samples anywhere, at the point of sale or at the customers' workplace.

**Weight:** 1,25 kg  
**Dimensions:** 9,9x9x23,5 cm  
**Display:** LCD 240x320

La geometría de bola de Datacolor D20 permite una medición precisa del color sobre muestras lisas y con relieves. La determinación del brillo de la muestra, combinada con la compensación del brillo en el software, permite una formulación de color visualmente perfecta.

El instrumento portátil permite medir cualquier muestra en cualquier lugar, en el punto de venta o en el lugar de trabajo de su cliente.

**Peso:** 1,25 kg  
**Dimensiones:** 9,9x9x23,5 cm  
**Display:** LCD 240x320

## color reader



Dispositivo di selezione dei colori ultra-portatile, per una migliore affidabilità nella lettura del colore.

Presenta una corrispondenza leader del settore con un successo superiore al 95% sui campionari di colori più diffusi, (oltre 10.000 colori) trovando in pochi secondi il colore più somigliante.

L'app mobile ColorReader fornisce tutto ciò che serve ai decoratori per individuare i colori corrispondenti, lavorare con i campionari di colori, creare e condividere le tavolozze sullo smartphone iPhone® o Android™.

**Diametro:** 30,22 mm  
**Lunghezza:** 108,8 mm  
**Peso:** 61,5 grammi  
**Contenuto della confezione:** Dispositivo ColorReaderPRO, borsa per il trasporto, cavo Micro USB, diapositiva di calibrazione, scheda di benvenuto

Portable colour matching tool, to better identify the colors of paints.

leading in this sector, its success' rate is above 95% for the most common colour samples (over 10.000) finding the most similar colour in just few seconds.

The ColorReader mobile app provides everything that decorators need in order to find the matching colours, work with colour samples, create and share palettes on iPhone® or Android™ smartphone.

**Diameter:** 30,22 mm  
**Length:** 108,8 mm  
**Weight:** 61,5 grams  
**Package contents:** ColorReaderPRO device, carrying bag, Micro USB cable, calibration slide, welcome card

Dispositivo de selección de color ultraportátil, para mayor confiabilidad en la lectura de la Gama de colores.

Presenta una correspondencia líder en la industria con un éxito de más del 95% en las muestras de color más populares (más de 10,000 colores), encontrando los Gama de colores más similares en segundos.

La aplicación móvil ColorReader proporciona todo lo que los decoradores necesitan para identificar colores coincidentes, trabajar con muestras de color, crear y compartir paletas en el teléfono inteligente iPhone® o Android™.

**Diámetro:** 30,22 mm  
**Longitud:** 108,8 mm  
**Peso:** 61,5 grammi  
**Contenido de la caja:** dispositivo ColorReaderPRO, bolsa de transporte, cable micro USB, diapositiva de calibración, tarjeta de bienvenida

## stampante dymo label writer 550



Design innovativo

**Velocità di stampa:** 62 etichette al minuto. Back-up automatico della prima etichetta. Connessione USB

Advanced design

**Print speed:** 62 labels per minute. Automatic back-up of the first label. USB connection

Design innovativo

**Velocidad de impresión:** 62 etiquetas por minuto. Copia de seguridad automática de la primera etiqueta. Conexión USB

## coloranti concentrati rie per prodotti all'acqua

 scheda  
tecnica

 data  
sheet

 ficha  
técnica

	interno esterno		indoor outdoor		interior exterior
	** non utilizzabili per prodotti alla calce		** cannot be used with lime-based product		** no utilizable para productos de cal

## coloranti concentrati ri per prodotti all'acqua

 scheda  
tecnica

 data  
sheet

 ficha  
técnica

	interno		indoor		interiores

## coloranti concentrati rie per prodotti al solvente

 scheda  
tecnica

 data  
sheet

 ficha  
técnica

	interno esterno		indoor outdoor		interior exterior
	** non utilizzabili per prodotti alla calce		** cannot be used with lime-based product		** no utilizable para productos de cal

## coloranti concentrati ri per prodotti al solvente

 scheda  
tecnica

 data  
sheet

 ficha  
técnica

	interno		indoor		interiores

# youcolor

prodotti a tintometro - products colourable with tinting machines - productos al tintómetro

Il sistema tintometrico IVAS è composto da macchine tintometriche, software e paste coloranti (Coloranti Concentrati IVAS) che permettono l'erogazione di oltre 100.000 formulazioni colore.

I prodotti colorabili con sistemi tintometrici IVAS, nelle tinte indicate nel dettaglio di ogni singolo prodotto, sono i seguenti:

The IVAS tinting machine systems are comprised of tinting machines, software and paste colourants (Coloranti Concentrati IVAS) that enable the dispensing of over 100,000 colour formulations.

The products that can be coloured with the IVAS tinting machine, in the colours indicated in detail of each single product, are as follows:

Los sistemas de tintado IVAS están compuestos por máquinas de tintado, software y pastas colorantes (Colorantes concentrados IVAS) que permiten la dispensación de más de 100.000 formulaciones de Gama de colores. Los productos que se pueden colorear con los sistemas de tintado IVAS, en los colores indicados en el detalle de cada producto individual, son los siguientes:

<b>best seller</b>	enjoy 1 coat
<b>idrosmalti</b>	idromatt
	idrosatin
	idrogloss
<b>lavabili</b>	clean matt
	luxury
	tech active
	sol-tex
<b>idropitture</b>	silan tech
	traspinterno
	mural verde
<b>vita sana</b>	vita wash
	sana bianca
	sanasil-bio
<b>paint ht</b>	silox plus
	superquarz plus
	ultra dry
	superclean plus
	superquarz plus strong
	ivasgum side finitura
	quarzogum plus
	idrobeton
	ivasil pittura
	deco sand plus
	ivaglass lucido
	ivaglass opaco
<b>exterior ht</b>	intonachino idrosiliconico g08
	intonachino idrosiliconico g06
	rivasil g15
	rivasil g12

<b>exterior</b>	finquarz	
	graffiato	
<b>smalti h2o</b>	real matt	
	real satin	
	real gloss	
	real tech	
	<b>smalti</b>	crystal
		crystal sx
aderlac hq		
	micafer	
<b>industria</b>	rapidex	
<b>TermoK8® finiture</b>	rivatone plus g15	
	rivatone plus g12	
	rivatone idrosiliconico plus g15	
	rivatone idrosiliconico plus g12	
	rivatone plus trv g15	
	rivatone plus trv g12	
	rivatone plus trv g10	
	rivatone plus strong g15	
	rivatone plus strong g12	
	rivatone clean plus g15	
	rivatone clean plus g12	
	rivatone clean plus g10	
	fondo k plus	
	<b>resin floor</b>	paviglass lucido
paviglass opaco		
epoxy paint lt		
davispaint		
	acquatop cover	
	acquatop walk	



Le tinte in queste pagine sono riproduzioni fotografiche e servono ad orientarsi per la selezione del prodotto. Essendo possibili differenze cromatiche tra queste tinte, i campioni, le cartelle colori e la produzione, non sono oggetto di reclamo.





The colors in these pages are photographic reproductions that are used to guide for the products selection. Possible differences in colour between these, samples, colour charts and production are likely to happen, so they are not subject of future complaint.

Los colores en estas páginas son reproducciones fotográficas y sirven para orientarse en la selección del producto. Debido a las posibles diferencias de color entre estos, las muestras, las carpetas de color y la producción no serán objeto de queja.

## Base

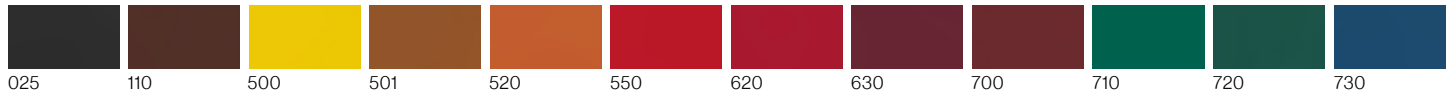

## Soffio

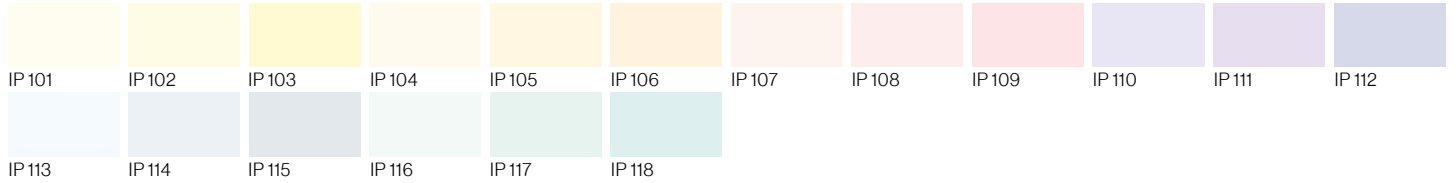

## Tenue

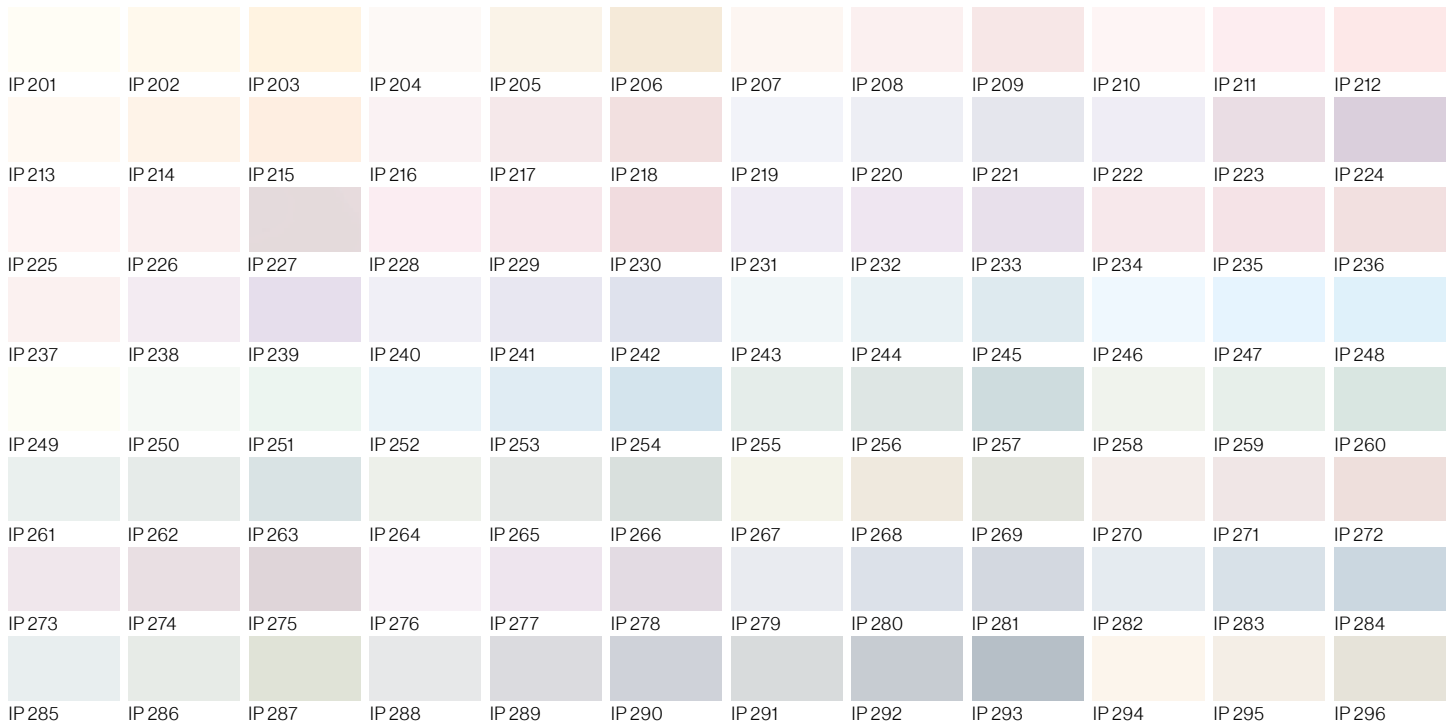

## Pastello

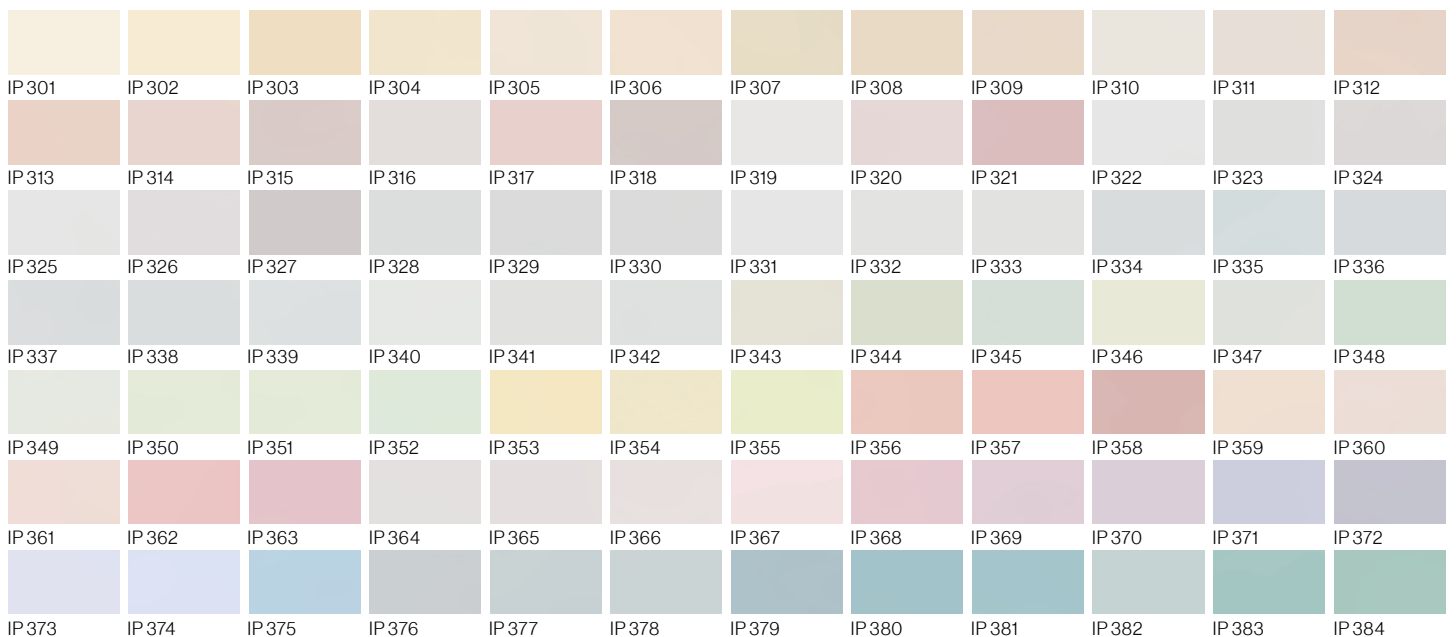

# Intenso

IP 401	IP 402	IP 403	IP 404	IP 405	IP 406	IP 407	IP 408	IP 409	IP 410	IP 411	IP 412
IP 413	IP 414	IP 415	IP 416	IP 417	IP 418	IP 419	IP 420	IP 421	IP 422	IP 423	IP 424
IP 425	IP 426	IP 427	IP 428	IP 429	IP 430	IP 431	IP 432	IP 433	IP 434	IP 435	IP 436
IP 437	IP 438	IP 439	IP 440	IP 441	IP 442	IP 443	IP 444	IP 445	IP 446	IP 447	IP 448
IP 449	IP 450	IP 451	IP 452	IP 453	IP 454	IP 455	IP 456	IP 457	IP 458	IP 459	IP 460
IP 461	IP 462	IP 463	IP 464	IP 465	IP 466	IP 467	IP 468	IP 469	IP 470	IP 471	IP 472
IP 473	IP 474	IP 475	IP 476	IP 477	IP 478	IP 479	IP 480	IP 481	IP 482	IP 483	IP 484
IP 485	IP 486	IP 487	IP 488	IP 489	IP 490	IP 491	IP 492	IP 493	IP 494	IP 495	IP 496
IP 497	IP 498	IP 499	IP 500	IP 501	IP 502	IP 503	IP 504	IP 505	IP 506	IP 507	IP 508
IP 509	IP 510	IP 511	IP 512	IP 513	IP 514	IP 515	IP 516	IP 517	IP 518	IP 519	IP 520
IP 521	IP 522	IP 523	IP 524	IP 525	IP 526	IP 527	IP 528	IP 529	IP 530	IP 531	IP 532

Le tinte in queste pagine sono riproduzioni fotografiche e servono ad orientarsi per la selezione del prodotto. Essendo possibili differenze cromatiche tra queste tinte, i campioni, le cartelle colori e la produzione, non sono oggetto di reclamo.

The colors in these pages are photographic reproductions that are used to guide for the products selection. Possible differences in colour between these, samples, colour charts and production are likely to happen, so they are not subject of future complaint.

Los colores en estas páginas son reproducciones fotográficas y sirven para orientarse en la selección del producto. Debido a las posibles diferencias de color entre estos, las muestras, las carpetas de color y la producción no serán objeto de queja.

## Off-White

KD04	KD07	KC41	KC37	KC45	KE01	KC42	KC44	KD30	KD31	KB31	KA02
KD01	KD02	KD19	KE02	KE03	KD16	KC46	KC47	KC40	KE04	KC39	KE05
KC38	KE06										

## Architectural

KC43	KE07	KA04	KE08	KA09	KA05	KD33	KE09	KA10	KE10	KA11	KE11
KA06	KE12	KE13	KA07	KD35	KE14	KE15	KB37	KE16	KE17	KD12	KD13
KD10	KD11	KD08	KD09	KD05	KD06	KD32	KB34	KD34	KB33	KD20	KD21
KD17	KD18	KD22	KE18	KD23	KD24	KE19	KD25	KD28	KD29	KD51	KD52
KD26	KD27	KB35	KD36	KD37	KD38	KD46	KD47	KD44	KD45	KE20	KE21
KD40	KD41	KD42	KE22	KD43	KA91	KC35	KC36	KC34	KB49	KB41	KC33
KE23	KE24	KE63	KE25	KE26	KE27	KD14	KD15	KD03	KE28	KE29	KE30
KE31	KE32	KE33	KE34	KE35	KE36	KE37	KE38	KE39	KE40	KE41	KE42
KC05	KE43	KC06	KD48	KE44	KE45	KD49	KD50	KC07	KE48	KC08	KA16
KC09	KA17	KA20	KA18	KA19	KA21	KC02	KC03	KC01	KC10	KA86	KA42
KC11	KC12	KC15	KE49	KA53	KC16	KA79	KC19	KE50	KA78	KA54	KA77
KA75	KA76	KC21	KC22	KA60	KC20	KE51	KA66	KA64	KA65	KA61	KA59
KA62	KA63	KA51	KA52	KE52	KA70	KE53	KA71	KE54	KA87	KA83	KA84
KA81	KE55	KA13	KA15	KE56	KA23	KE57	KA24	KE58	KA90		

## Premium

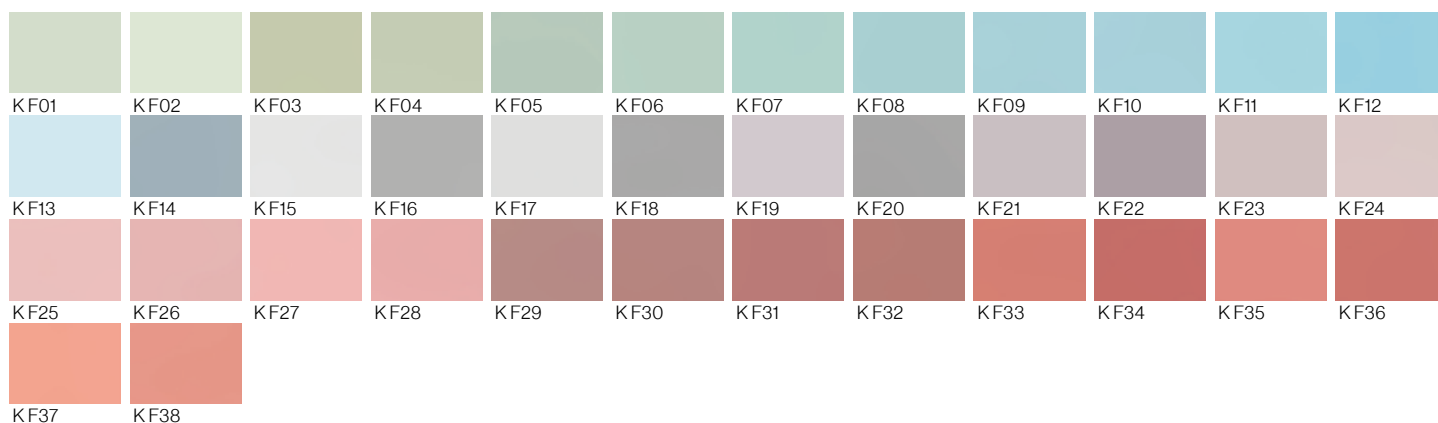

## Solar

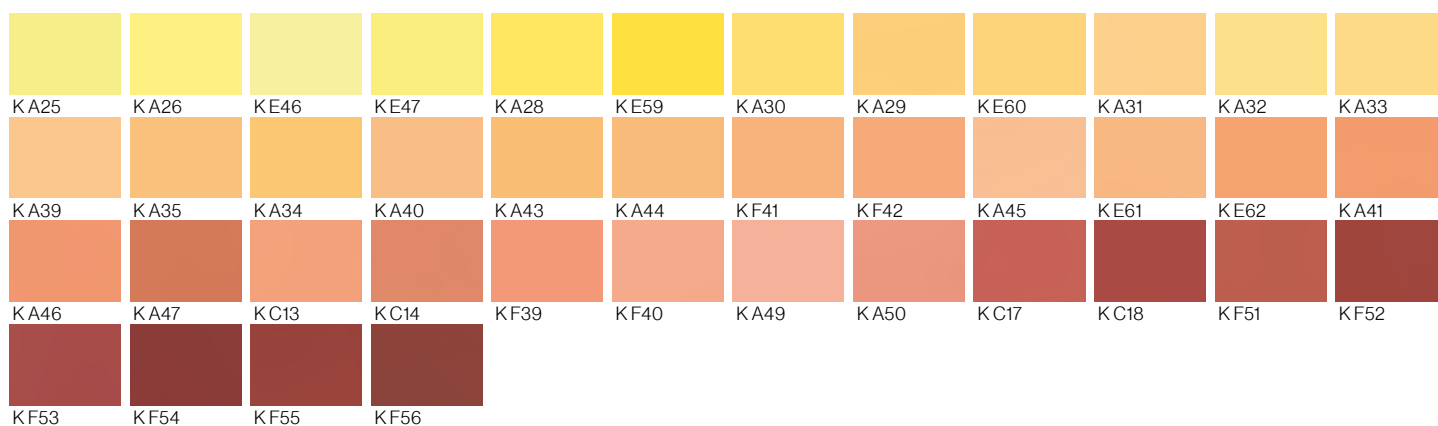

## Diamond



## Strong

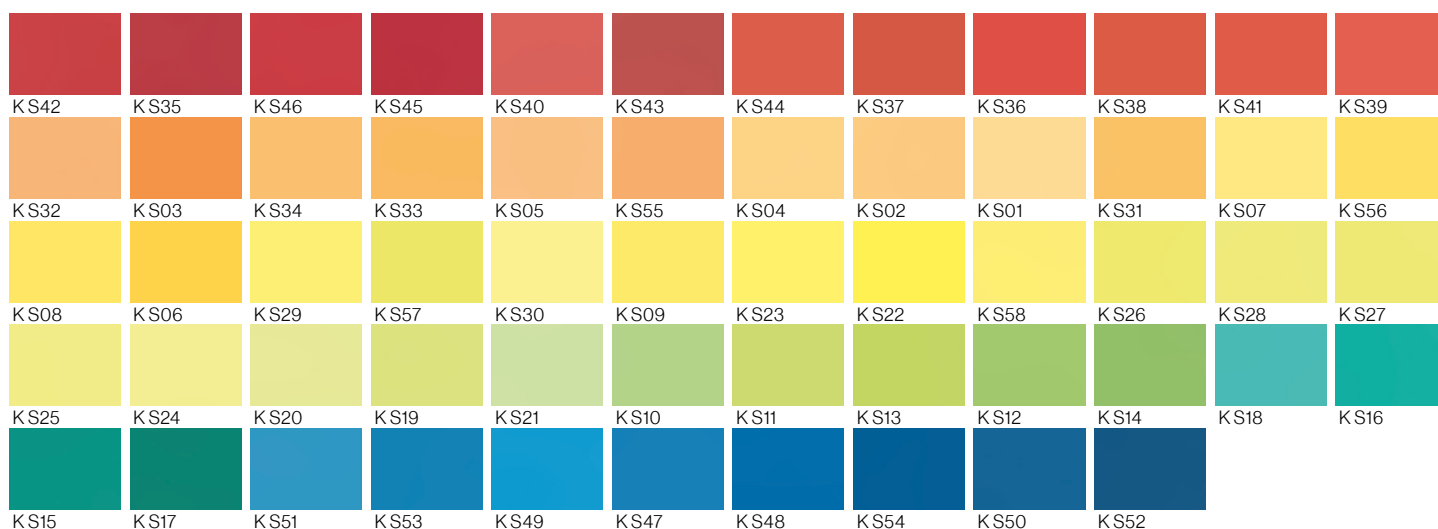

Le tinte in queste pagine sono riproduzioni fotografiche e servono ad orientarsi per la selezione del prodotto. Essendo possibili differenze cromatiche tra queste tinte, i campioni, le cartelle colori e la produzione, non sono oggetto di reclamo.

The colors in these pages are photographic reproductions that are used to guide for the products selection. Possible differences in colour between these, samples, colour charts and production are likely to happen, so they are not subject of future complaint.

Los colores en estas páginas son reproducciones fotográficas y sirven para orientarse en la selección del producto. Debido a las posibles diferencias de color entre estos, las muestras, las carpetas de color y la producción no serán objeto de queja.



## Aderlac HQ

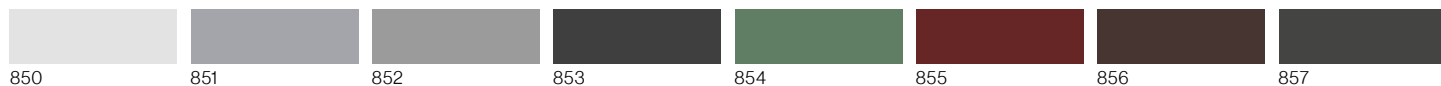

## Aquapox



## Crystal - Crystal Sx

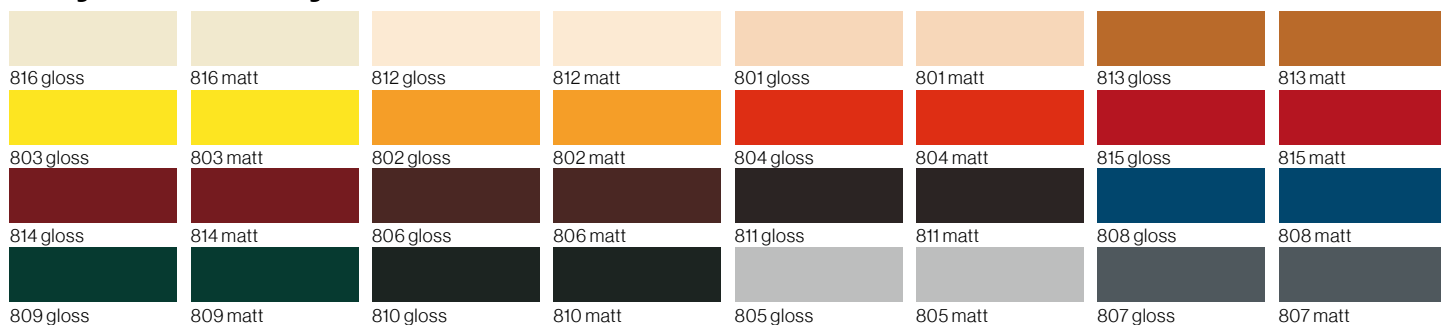

## Micafer

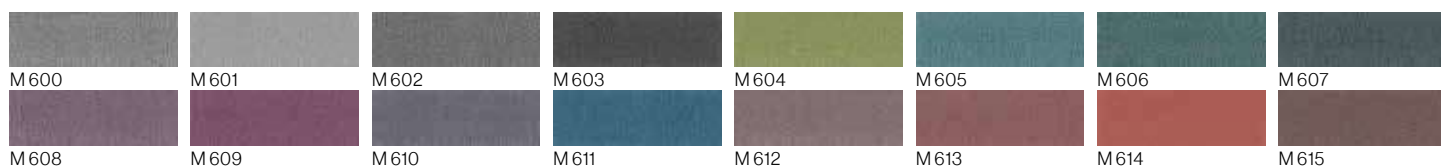

## Primex HQ

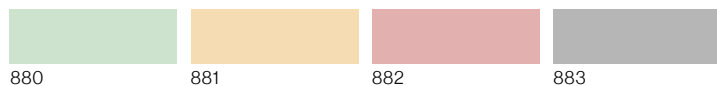

Le tinte in queste pagine sono riproduzioni fotografiche e servono ad orientarsi per la selezione del prodotto. Essendo possibili differenze cromatiche tra queste tinte, i campioni, le cartelle colori e la produzione, non sono oggetto di reclamo.

The colors in these pages are photographic reproductions that are used to guide for the products selection. Possible differences in colour between these, samples, colour charts and production are likely to happen, so they are not subject of future complaint.

Los colores en estas páginas son reproducciones fotográficas y sirven para orientarse en la selección del producto. Debido a las posibles diferencias de color entre estos, las muestras, las carpetas de color y la producción no serán objeto de queja.

# RAL Classic K7

							
RAL 1000	RAL 1001	RAL 1002	RAL 1003	RAL 1004	RAL 1005	RAL 1006	RAL 1007
							
RAL 1011	RAL 1012	RAL 1013	RAL 1014	RAL 1015	RAL 1016	RAL 1017	RAL 1018
							
RAL 1019	RAL 1020	RAL 1021	RAL 1023	RAL 1024	RAL 1027	RAL 1028	RAL 1032
							
RAL 1033	RAL 1034	RAL 1037	RAL 2000	RAL 2001	RAL 2002	RAL 2003	RAL 2004
							
RAL 2008	RAL 2009	RAL 2010	RAL 2011	RAL 2012	RAL 3000	RAL 3001	RAL 3002
							
RAL 3003	RAL 3004	RAL 3005	RAL 3007	RAL 3009	RAL 3011	RAL 3012	RAL 3013
							
RAL 3014	RAL 3015	RAL 3016	RAL 3017	RAL 3018	RAL 3020	RAL 3022	RAL 3027
							
RAL 3028	RAL 3031	RAL 4001	RAL 4002	RAL 4003	RAL 4004	RAL 4005	RAL 4006
							
RAL 4007	RAL 4008	RAL 4009	RAL 4010	RAL 5000	RAL 5001	RAL 5002	RAL 5003
							
RAL 5004	RAL 5005	RAL 5007	RAL 5008	RAL 5009	RAL 5010	RAL 5011	RAL 5012
							
RAL 5013	RAL 5014	RAL 5015	RAL 5017	RAL 5018	RAL 5019	RAL 5020	RAL 5021
							
RAL 5022	RAL 5023	RAL 5024	RAL 6000	RAL 6001	RAL 6002	RAL 6003	RAL 6004
							
RAL 6005	RAL 6006	RAL 6007	RAL 6008	RAL 6009	RAL 6010	RAL 6011	RAL 6012
							
RAL 6013	RAL 6014	RAL 6015	RAL 6016	RAL 6017	RAL 6018	RAL 6019	RAL 6020
							
RAL 6021	RAL 6022	RAL 6024	RAL 6025	RAL 6026	RAL 6027	RAL 6028	RAL 6029
							
RAL 6032	RAL 6033	RAL 6034	RAL 6037	RAL 7000	RAL 7001	RAL 7002	RAL 7003
							
RAL 7004	RAL 7005	RAL 7006	RAL 7008	RAL 7009	RAL 7010	RAL 7011	RAL 7012
							
RAL 7013	RAL 7015	RAL 7016	RAL 7021	RAL 7022	RAL 7023	RAL 7024	RAL 7026
							
RAL 7030	RAL 7031	RAL 7032	RAL 7033	RAL 7034	RAL 7035	RAL 7036	RAL 7037
							
RAL 7038	RAL 7039	RAL 7040	RAL 7042	RAL 7043	RAL 7044	RAL 7045	RAL 7046
							
RAL 7047	RAL 8000	RAL 8001	RAL 8002	RAL 8003	RAL 8004	RAL 8007	RAL 8008
							
RAL 8011	RAL 8012	RAL 8014	RAL 8015	RAL 8016	RAL 8017	RAL 8019	RAL 8022
							
RAL 8023	RAL 8024	RAL 8025	RAL 8028	RAL 9001	RAL 9002	RAL 9003	RAL 9004
							
RAL 9005	RAL 9006	RAL 9007	RAL 9010	RAL 9011	RAL 9016	RAL 9017	RAL 9018



**corner**  
**espos**

# corner espositivi

I corner espositivi rappresentano un modo nuovo di proporre i prodotti e le soluzioni ivas all'interno dei punti vendita, attraverso moduli componibili a seconda delle necessità e degli spazi disponibili.

The exhibition corners represent a new way of showing our products and solutions inside every store, through modular units according to needs and space availability.

Los rincones expositivos representan una nueva forma de proponer productos y soluciones ivas al interior de las tiendas, a través de elementos modulares de acuerdo a las necesidades y espacios disponibles.

# s sitivi

<p>I corner espositivi rappresentano un modo nuovo di proporre i prodotti e le soluzioni ivas all'interno dei punti vendita, attraverso moduli componibili a seconda delle necessità e degli spazi disponibili.</p>	<p>The exhibition corners represent a new way of proposing ivas products and solutions into the stores, through modular modules according to the needs and to the available spaces.</p>	<p>Los rincones expositivos representan una nueva forma de proponer productos y soluciones ivas al interior de las tiendas, a través de elementos modulares de acuerdo a las necesidades y espacios disponibles.</p>
<p><b>componenti strutturali comuni:</b></p> <ul style="list-style-type: none"> <li>- struttura metallica autoportante tubolare cm 30x30</li> <li>- cappello melamminico laccato cm 30x38x90 completo di n° 2 faretti led</li> <li>- schiena melamminica laccata cm 60+147x90c</li> <li>- base melamminica laccata 50x90cm</li> <li>- piedini regolabili autolivellanti</li> <li>- piede posteriore aggiuntivo per configurazione autoportante</li> <li>- accessori di sicurezza antiribaltamento</li> <li>- finitura poliuretana antigraffio</li> </ul>	<p><b>common structural components:</b></p> <ul style="list-style-type: none"> <li>- self-supporting tubular metal structure 30x30 cm lacquered melamine hat 30x38x90 cm complete with 2 led spotlights</li> <li>- lacquered melamine back cm 60 + 147x90</li> <li>- lacquered melamine base 50x90cm</li> <li>- self-leveling adjustable feet</li> <li>- additional rear foot for self-supporting configuration</li> <li>- rollover safety accessories</li> <li>- scratch-resistant polyurethane finish</li> </ul>	<p><b>componentes estructurales comunes:</b></p> <ul style="list-style-type: none"> <li>- estructura metálica tubular autoportante 30x30 cm tapa de melamina lacada cm 30x38x90 completa con n° 2 focos led</li> <li>- respaldo de melamina lacada cm 60+147x90c</li> <li>- base de melamina lacada 50x90cm</li> <li>- pies regulables y autonivelantes</li> <li>- pie trasero adicional para la configuración autoportante</li> <li>- accesorios de seguridad antivuelco</li> <li>- acabado poliuretano antirayaduras</li> </ul>
<p><b>accessori:</b></p> <ul style="list-style-type: none"> <li>- fianchi di chiusura</li> <li>- colonna angolare</li> <li>- schiena di finitura</li> </ul>	<p><b>Accessories:</b></p> <ul style="list-style-type: none"> <li>- closing sides</li> <li>- corner column</li> <li>- finishing back</li> </ul>	<p><b>accessori:</b></p> <ul style="list-style-type: none"> <li>- lados de cierre</li> <li>- column angular</li> <li>- acabado de vuelta</li> </ul>
<p><b>specifiche moduli singoli:</b></p> <p><u>modulo con tecnigrafo</u></p> <ul style="list-style-type: none"> <li>- "tecnigrafo" con piano inclinato magnetizzato cm 125x50x90, griglia magnetica con 18 campioni cm12x15 "colori dell'anno". Possibilità di sostituire la griglia con un monitor professionale 32" (opzionale)</li> </ul> <p><u>modulo interior trends</u></p> <ul style="list-style-type: none"> <li>- "muro del colore" con tutti i campioni delle tinte IT per interno griglia magnetica con 144 campioni cm 12x5,5</li> </ul> <p><u>modulo TermoK8</u></p> <ul style="list-style-type: none"> <li>- selezione di 8 campioni di sistemi a cappotto cm 40x40 removibili, con sistema di fissaggio autolivellante in tinta con la schiena</li> </ul> <p><u>modulo cicli tecnici</u></p> <ul style="list-style-type: none"> <li>- strutture con n. 3 pannelli girevoli bifacciali cm 133x28 (cadauno) mobile contenitore laccato cm 60x50x90 completo di top aggiuntivo</li> </ul> <p><u>modulo pavimenti in resina</u></p> <ul style="list-style-type: none"> <li>- strutture con n. 3 pannelli girevoli bifacciali cm 133x28 (cadauno) mobile contenitore laccato cm 60x50x90 completo di top aggiuntivo</li> </ul> <p><u>modulo decorativi</u></p> <ul style="list-style-type: none"> <li>- griglia magnetica con 16 campioni Metropolis cm 18,75x30 intercambiabili, mobile contenitore laccato cm 60x50x90 completo di top aggiuntivo contenete un ulteriore set di campioni magnetici.</li> </ul>	<p><b>single modules specifics:</b></p> <p><u>module with drafting machine</u></p> <ul style="list-style-type: none"> <li>- "drafting machine" with magnetized inclined plane 125x50x90, magnetic grid with 18 samples cm12x15 "colours of the year". Possibility to replace the grid with a professional monitor 32" (optional)</li> </ul> <p><u>interior trends module</u></p> <ul style="list-style-type: none"> <li>- "wall of colour" with all the color samples IT for interiors magnetic grid with 144 samples cm 12x5,5</li> </ul> <p><u>termoK8 module</u></p> <ul style="list-style-type: none"> <li>- Selection of 8 samples of external insulation systems cm 40x40 removable, with self-leveling fixing system matching the back.</li> </ul> <p><u>technical cycles module</u></p> <ul style="list-style-type: none"> <li>- Structures with n.3 double-sided rotating panels cm 133x28 (each one) mobile lacquered container cm 60x50x90 complete with additional top</li> </ul> <p><u>resin floor module</u></p> <ul style="list-style-type: none"> <li>- Structures with n. 3 double-sided rotating panels cm 133x28 (each one) mobile lacquered container cm 60x50x90 complete with additional top</li> </ul> <p><u>decorative module</u></p> <ul style="list-style-type: none"> <li>- Magnetic grid with 16 samples of Metropolis cm 18,75x30 interchangeable, mobile lacquered container cm 60x50x90 complete with additional top containing an extra set of magnetic samples.</li> </ul>	<p><b>specifiche moduli singoli:</b></p> <p><u>módulo de dibujo técnico</u></p> <ul style="list-style-type: none"> <li>- "tecnigrafo" con piano inclinato magnetizzato cm 125x50x90, griglia magnetica con 18 campioni cm12x15 "colores dell'anno". Possibilità di sostituire la griglia con un monitor professionale 32" (opzionale)</li> </ul> <p><u>modulo interior trends</u></p> <ul style="list-style-type: none"> <li>- "muro de color" con todas las muestras de color IT para interior rejilla magnética con 144 muestras 12x5,5 cm</li> </ul> <p><u>módulo TermoK8</u></p> <ul style="list-style-type: none"> <li>- selección de 8 muestras de sistemas de revestimiento de 40x40 cm desmontable, con sistema de fijación autonivelante a juego con el soporte</li> </ul> <p><u>módulo ciclos técnicos</u></p> <ul style="list-style-type: none"> <li>- estructura con no. 3 paneles giratorios de doble cara cm 133x28 (cada uno) mueble de almacenamiento lacado cm 60x50x90 completo con tapa adicional</li> </ul> <p><u>módulo pavimentos en resina</u></p> <ul style="list-style-type: none"> <li>- estructura con no. 3 paneles giratorios de doble cara cm 133x28 (cada uno) mueble de almacenamiento lacado cm 60x50x90 completo con tapa adicional</li> </ul> <p><u>módulo decorativos</u></p> <ul style="list-style-type: none"> <li>- rejilla magnética con 16 muestras intercambiables de Metropolis 18,75x30 cm, armario lacado cm 60x50x90 completo con tapa adicional que contiene un conjunto adicional de muestras magnéticas</li> </ul>

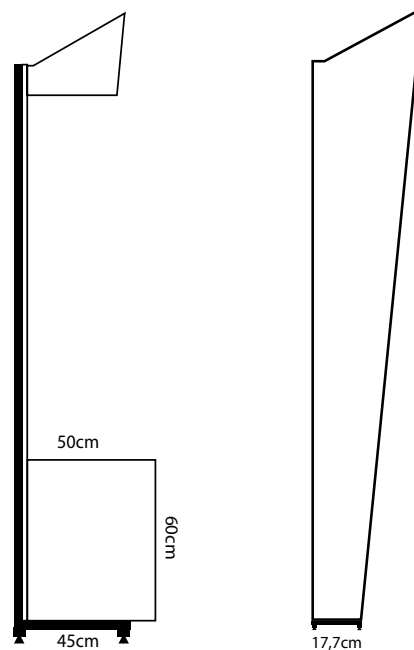
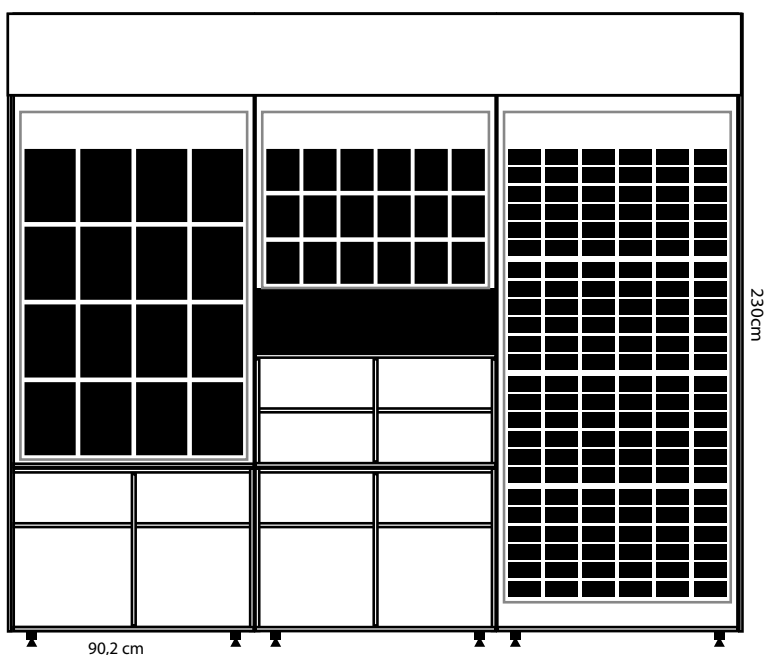



Configurazione lineare  
Montaggio a parete oppure autoportante (anche bifacciale)



Configurazione angolare  
Montaggio a parete oppure autoportante, con angolo accessorio



Configurazione freestanding  
Montaggio autoportante monofacciale oppure bifacciale



Configurazione ad isola  
Montaggio "a torre" centrale, 4 moduli a pianta quadrata





**strumente  
vendite**

# strumenti di vendita

Ivas presenta una linea completa e rinnovata di strumenti di comunicazione, promozione e vendita. Al suo interno sono disponibili i cataloghi, i manuali tecnici, le cartelle colore e tutti gli strumenti di comunicazione delle principali linee di prodotto.

Ivas presents a complete and renewed line of communication, promotion and sales tools. Internally it presents Catalogs, technical sheets, color folders and all communication tools

Ivas presenta una completa y renovada línea de instrumentos de comunicación, promoción y venta. Los catálogos están disponibles en su interior, manuales técnicos, cartas de colores y todas las herramientas de comunicación de las principales líneas de productos.



# enti di a

<b>A</b>			
acquatop cover	275	copritassel	165
acquatop fix	274	corindone bianco	276
acquatop primer	274	corindone bruno	276
acquatop walk	275	cornice sottogronda	198
acrilica 100	81	crystal	94
acrilux	104	crystal sx	94
adefix 12 bianco	135	<b>D</b>	
adefix 12 grigio	135	davanzali ALU	184
aderlac hq	95	davanzali GFB	184
aeropan	161	davispaint	265
aerosil 200	277	deco sand plus	57
agitatore elettronico giroscopico	288	deco sand plus	57
agitatore manuale giroscopico	288	detergente ac	110
algasol	104	diluyente nitro antinebbia	119
amianfix	108	diluyente per epossidici	119
angolare esterno	253	diluyente per poliuretani	119
angolare interno	253	diluyente per spartitraffico	119
antigraffiti w	103	diluyente sintetico	119
antiruggine per carrozzeria	116	<b>E</b>	
aquacem	261	elastucco	84
aquacem autolivellante	261	elementi di compensazione	178
aquapox	264	enjoy 1 coat	17
armatex C1	186	epoplast	270
armatex C1 M	187	epoplast 61	272
armatex C1 R	186	epoplast as	271
armatex micro	113	epoplast flex	271
artemisia	226	epoplast w	270
artemisia rasopietra	226	epoxy bond	262
asfodelo	224	epoxy fondo	260
asfodelo 530 bianco	225	epoxy fondo as	261
asfodelo rinzafo antisale	224	epoxy fondo oil	260
asfodelo risanante	225	epoxy paint ht	264
		epoxy paint lt	265
<b>B</b>		epoxy primer wb	258
banda	253	epoxy primer xb	258
bandella di rame	280	epozinco	116
barra di fissaggio Vari Q	180	eps 31-G 100 fix R	153
betonglass lucido	59	eps 31-G max R	153
betonglass opaco	59	eps 35-100 fix R	152
biancocalce	33	eps 35 max R	152
bianco interno	33	eps 35 plus	156
bio-past	112	eps G meccanico R	153
bitum flex	109	eps meccanico R	152
bloccafumo	81	espositore prodotti vita sana	42
bugna	199		
		<b>F</b>	
<b>C</b>		fibra di legno	161
capsulit	108	finquarz	68
cassetta elettrica Eldoline EPS	180	fondo H2O per legno	98
catalizzatore z8	113	fondo K plus	195
celertow	237	fondo per legno	98
cerato	127	fresa per risanamento PTZ	200
cips colorate	277	fresa per risanamento STR	200
clean matt	24	<b>G</b>	
clorex	117	giunto di dilatazione plus PVC-R	177
cloro-pool	123	glueflex bianco	230
colonna porta gel	45	glueflex grigio	230
coloranti concentrati youcolor rie per prodotti all'acqua	290	glueflex hp bianco	231
coloranti concentrati youcolor rie per prodotti al solvente	290	glueflex hp grigio	231
coloranti concentrati youcolor ri per prodotti all'acqua	290	glueflex modular big bianco	142
coloranti concentrati youcolor ri per prodotti al solvente	290	glueflex modular big grigio	142
coloranti universali re	87	glueflex p	143
coloranti universali ri	87	glueflex ultra bianco	232
color reader	289	glueflex ultra grigio	232
converto 30 BW	150	graffiato	69
converto 30-G	146	grafinet	110
converto 31 BW	150	griptow	209
converto 31-G plus	146	guarnizione grande	253
converto 34 BW	151	guarnizione piccola	253
converto 35-100	148	<b>I</b>	
converto fonostop	147	idrobeton	56
converto HP	147	idrocerato	129
converto P 200	148	idrofill	129
converto P 200 HP	154	idroflating	128
		idroflating opaco	128
		idrofless gloss	34
		idrofless matt	34
		idrofumo	35
		idrogloss	21
		idromatt	20
		idrosatin	20
		inserto dart-set	179
		inserto di rinforzo Quadroline	180
		inserto per il montaggio CT 2G	200
		inserto per il montaggio CT L	200
		inserto per il montaggio CT S1	201
		inter-pool	122
		intogum plus g10	62
		intogum plus g12	62
		intonachino idrosiliconico plus g06	63
		intonachino idrosiliconico plus g08	63
		iso-bar	179
		iso-corner	182
		iso-corner kit SDF	183
		iso-corner kit SDP	183
		ivaglass lucido	58
		ivaglass opaco	58
		ivapox antiacido	268
		ivasgum fondo	77
		ivasgum side finitura	55
		ivasil fondo	77
		ivasil intonachino g08	65
		ivasil pittura	56
		ivasil primer s	81
		ivastucco	84
		<b>K</b>	
		kit montaggio profili di base	178
		kit ricambi per talpa - CT 2G e CT L	201
		klebocalce naturale	140
		klebocem	134
		klebocem fibrato	138
		klebocem grosso	134
		klebocem minerale	140
		klebocem r 110 j	139
		klebocem termico	138
		klebocem ultra	139
		<b>L</b>	
		lana di roccia doppia densità	158
		lana di roccia monodensità	158
		lana di vetro k34	159
		lecocem 100	136
		listello a mano san marco	196
		listello facciavista	196
		listello flex	196
		listello buchta	196
		luxury	24
		<b>M</b>	
		malta modellabile	237
		marcapiano	198
		marineria	126
		marineria opaco	126
		micafer	95
		microfibra 80	277
		minio oleofenolico	99
		mixer glos	287
		monoflex	247
		multipor	159
		mural blu	32
		muralpac liscio	109
		mural verde	29
		<b>N</b>	
		nastro autoespandente sigillante BG1	175
		nitrofix	80
		novostucco	85
		<b>P</b>	
		paraspigolo angolare AL	170
		paraspigolo angolare AL-R	171
		paraspigolo angolare archi PVC	171
		paraspigolo angolare flex PVC-R	172
		paraspigolo angolare PVC	171
		paraspigolo angolare PVC-R	171
		parastuck	144
		parastuck mf	143

paviglass lucido .....	266
paviglass opaco .....	266
perline vetro .....	277
PH 20 .....	160
PH 20 king .....	161
piastra per carichi pesanti ump-alu-tr .....	181
pittura per interni extra .....	32
polybeton ht .....	278
polybeton ls .....	278
polyelastic .....	272
polyfast ib .....	279
polyfast p .....	279
primacril .....	80
primer mma .....	259
primer-pool .....	122
primer ra .....	251
primer tack .....	251
primer therm .....	39
prime tech .....	76
primex hq .....	99
profilo C di colmo .....	174
profilo CO di contenimento .....	174
profilo con gocciolatoio PVC-R .....	172
profilo di base .....	170
profilo di base PVC-R .....	170
profilo di chiusura PVC-R .....	174
profilo di collegamento PVC-R .....	173
profilo di connessione PVC U-AL .....	167
profilo di connessione TYP U .....	167
profilo di giunto semplice GA-R .....	177
profilo di giunto semplice GL-R .....	177
profilo finestre plus 3d PVC-R .....	173
profilo finestre plus PVC-R .....	173
profilo finestre PVC-R .....	172
profilo orizzontale OR/LT .....	168
profilo orizzontale PVC OR/LT .....	168
profilo per rivestimenti modulari .....	175
profilo SD sottodanzale .....	172
profilo verticale PVC VR/LT .....	169
profilo verticale VR/LT .....	169
punta per trapano high speed .....	200
<b>Q</b>	
quarzo 02 .....	276
quarzo 04 .....	276
quarzo 06 .....	276
quarzogum plus .....	55
quarzoplast .....	68
<b>R</b>	
rapidex .....	117
rasaltow 108 bianco .....	214
rasaltow beton bianco .....	215
rasaltow beton grigio .....	215
rasaltow bianco .....	213
rasaltow grigio .....	213
rasaltow max bianco .....	212
rasaltow max grigio .....	212
rasaltow plus 1.0 .....	214
rasofondo color .....	76
rasofondo flex .....	77
rasogum .....	141
real gloss .....	91
real matt .....	90
real satin .....	90
real tech .....	91
resintow .....	251
rete fazzoletto per armatura spigoli finestre .....	187
rete angolare per intradossi aperture .....	187
rete fuga decorativa .....	176
rete fuga decorativa angolo esterno .....	176
rete fuga decorativa angolo interno .....	176
reverso .....	154
rivasil g12 .....	64
rivasil g15 .....	64
rivatone clean plus g10 .....	195
rivatone clean plus g12 .....	194
rivatone clean plus g15 .....	194
rivatone idrosiliconico plus g12 .....	189
rivatone idrosiliconico plus g15 .....	189
rivatone plus g12 .....	188
rivatone plus g15 .....	188
rivatone plus reflect g12 .....	192
rivatone plus reflect g15 .....	192
rivatone plus strong g12 .....	193
rivatone plus strong g15 .....	193
rivatone plus trv g10 .....	191
rivatone plus trv g12 .....	190
rivatone plus trv g15 .....	190
rompigoccia per base di partenza-R .....	170
rondella per lana di roccia 90 mm .....	165
rondella per lana di roccia 140 mm .....	165
rondella per lana di roccia VT 2G .....	164
rugoplast .....	69
rusty .....	99
<b>S</b>	
sana bianca .....	40
sana finish .....	40
sana rasothersm .....	40
sana salute gel .....	44
sana salute oxy .....	45
sana salute pro indoor .....	44
sana salute pro outdoor .....	45
sana salute spray .....	44
sana salute sprayer pump .....	45
sanasil-bio .....	41
sana solux .....	41
sana solux spray .....	41
sigil pol .....	141
sigil tow fl .....	236
sigil tow universale .....	236
silacril .....	103
silan tech .....	28
silcal .....	102
silcal w .....	102
silofix .....	80
silox plus .....	52
software datacolor paint color cardmatch .....	288
software datacolor paint efb .....	288
software per spettrofotometro .....	288
sol-tex .....	25
spalletta isolante per imbotte lai-sys eps .....	166
spalletta isolante per imbotte lai-sys mw .....	166
spalletta isolante per imbotte lai-sys pu .....	166
spartitraffico .....	111
spatola sagomata .....	201
spettrofotometro datacolor d20 .....	289
stampante dymo label writer 550 .....	289
stiferite class SK .....	160
stonet .....	110
stucco in polvere .....	85
sughero ambrato .....	160
superclean plus .....	53
superquarz plus .....	52
superquarz plus reflect .....	54
superquarz plus strong .....	54
supporto di fissaggio frontale tra-wik-alu-rf .....	181
supporto di fissaggio k1-pe .....	181
supporto di fissaggio laterale tra-wik-alu-rl .....	182
sverniciatore n11 .....	112
<b>T</b>	
tagliatrice per eps da ponteggio .....	201
talpa per tassello CT 2G - CT L .....	201
talpa per tassello CT S1 .....	201
tappo in EPS per tassello CT 2G - CT L .....	165
tassello CT 2G .....	162
tassello CT L .....	163
tassello CT L A2 .....	163
tassello CT S1 .....	163
tassello di ancoraggio a spirale .....	178
tassello H2 .....	162
tassello H3 .....	164
tassello ND K .....	164
tassello SDK U .....	164
tech active .....	25
terminale per sottotetto PVC-R .....	173
TermoK8 foam .....	141
tessuto di vetro .....	280
thinner fill .....	127
tintometro a4b .....	284
tintometro d600 minimodula .....	286
tintometro elettronico d300 .....	285
tintometro elettronico d700 .....	286-287
tintometro ha480 .....	285
tintometro manuale .....	284
totem promozionale vita sana .....	42
tow bf .....	219
tow bk bianco .....	219
tow bk grigio .....	218
tow bn anticarbonatazione .....	218
tow bn r bianco .....	221
tow bn r grigio .....	221
towcem .....	209
towrip .....	206
towrip 108 .....	206
towrip betoncino .....	207
towrip colabile .....	207
towrip & finish .....	208
towrip rapido .....	208
towseal .....	247
towflex .....	246
towflex ap .....	246
tow level .....	243
towpruf .....	248
tow-rin .....	241
towsan .....	240
towsan finitura .....	241
towsan light .....	240
towsan primer .....	240
traspicolor active .....	16
traspinterno .....	28
<b>U</b>	
ultra dry .....	53
uniform bianco .....	220
uniform grigio .....	220
<b>V</b>	
vita bianca .....	38
vita therm .....	39
vita wash .....	38
<b>W</b>	
white cream .....	29
<b>Z</b>	
zincobrill .....	111



---

contatti

Ivas Industria Vernici Spa  
via Bellaria 40 · 47030  
San Mauro Pascoli · FC · Italia

tel. +39 0541 815811  
mail [ivas@gruppivas.com](mailto:ivas@gruppivas.com)  
web [gruppivas.com](http://gruppivas.com)

edizione 05/2022

Company with quality management system certified UNI EN ISO 9001