

I.V.A.S Industria Vernici S.p.A

Via Bellaria, 40

I-47030

San Mauro Pascoli (FC)

Italy

Tel: 01189 635 900 Fax: 01189 635 901

e-mail: enquiries@gruppoivas.co.uk

website: www.gruppoivas.com



Agrément Certificate

11/4841

Product Sheet 2

TERMOK8 EXTERNAL WALL INSULATION SYSTEMS

TERMOK8 CLASSICO MINERALE EXTERNAL WALL INSULATING RENDER SYSTEM

This Agrément Certificate Product Sheet⁽¹⁾ relates to the Termok8 Classico Minerale External Wall Insulating Render System, comprising mineral wool and mineral wool lamella insulation slabs adhesively fixed with supplementary mechanical fixings, with reinforced render finishes. It is suitable for use on the outside of external walls in new and existing domestic and non-domestic buildings.

(1) Hereinafter referred to as 'Certificate'.

CERTIFICATION INCLUDES:

- factors relating to compliance with Building Regulations where applicable
- factors relating to additional non-regulatory information where applicable
- independently verified technical specification
- assessment criteria and technical investigations
- design considerations
- installation guidance
- regular surveillance of production
- formal three-yearly review.

KEY FACTORS ASSESSED

Thermal performance — the system can be used to improve the thermal performance of external walls and can contribute to meeting the requirements of the national Building Regulations (see section 6).

Strength and stability — the system can adequately resist wind loads and has sufficient resistance to impact damage (see section 7).

Behaviour in relation to fire — the system has a reaction to fire classification of A2-s1, d0 in accordance with BS EN 13501-1 : 2007 (see section 8).

Risk of condensation — the system can contribute to limiting the risk of interstitial and surface condensation (see section 11).

Durability — when installed and maintained in accordance with the Certificate holder's recommendations and the terms of the Certificate, the system will remain effective for at least 30 years (see section 13).



The BBA has awarded this Certificate to the company named above for the system described herein. This system has been assessed by the BBA as being fit for its intended use provided it is installed, used and maintained as set out in this Certificate.

On behalf of the British Board of Agrément

Brian Chamberlain

Brian Chamberlain

Head of Approvals — Engineering

Claire Curtis-Thomas

Claire Curtis-Thomas

Chief Executive

Date of First issue: 12 December 2014

Originally certificated on 13 May 2011

The BBA is a UKAS accredited certification body — Number 113. The schedule of the current scope of accreditation for product certification is available in pdf format via the UKAS link on the BBA website at www.bbacerts.co.uk

Readers are advised to check the validity and latest issue number of this Agrément Certificate by either referring to the BBA website or contacting the BBA direct.

British Board of Agrément

Bucknalls Lane

Watford

Herts WD25 9BA

tel: 01923 665300

fax: 01923 665301

e-mail: clientservices@bba.star.co.uk

website: www.bbacerts.co.uk

©2014

Regulations

In the opinion of the BBA, the TermoK8 Classico Minerale External Wall Insulating Render System, if installed, used and maintained in accordance with the provisions of this Certificate, can satisfy, or contribute to satisfying, the relevant requirements of the following Building Regulations (the presence of a UK map indicates that the subject is related to the Building Regulations in the region or regions of the UK depicted):



The Building Regulations 2010 (England and Wales) (as amended)

Requirement: A1	Loading
Comment:	The systems can sustain and transmit wind loads to the substrate wall. See section 7.4 of this Certificate.
Requirement: B4(1)	External fire spread
Comment:	The system can satisfy this Requirement. See sections 8.1 to 8.4 of this Certificate.
Requirement: C2(b)	Resistance to moisture
Comment:	The systems provide a degree of protection against rain ingress. See sections 4.4 and 10.1 of this Certificate.
Requirement: C2(c)	Resistance to moisture
Comment:	The systems can contribute to minimising the risk of interstitial and surface condensation. See sections 11.1, 11.2 and 11.4 of this Certificate.
Requirement: L1(a)(i)	Conservation of fuel and power
Comment:	The system can contribute to satisfying this Requirement. See sections 6.2 and 6.3 of this Certificate.
Regulation: 7	Materials and workmanship
Comment:	The system is acceptable. See section 13.1 and the <i>Installation</i> part of this Certificate.
Regulation: 26	CO₂ emission rate for new buildings
Regulation: 26A	Fabric energy efficiency rates for new dwellings (applicable to England only)
Regulation: 26A	Primary energy consumption rates for new buildings (applicable to Wales only)
Regulation: 26B	Fabric performance values for new dwellings (applicable to Wales only)
Comment:	The system can contribute to satisfying these Regulations. See sections 6.2 and 6.3 of this Certificate.



The Building (Scotland) Regulations 2004 (as amended)

Regulation: 8(1)(2)	Fitness and durability of materials and workmanship
Comment:	The system can contribute to a construction satisfying this Regulation. See sections 12 and 13.1 and the <i>Installation</i> part of this Certificate.
Regulation: 9	Building standards applicable to construction
Standard: 1.1	Structure
Comment:	The system can sustain and transmit wind loads to the substrate wall. See section 7.4 of this Certificate.
Standard: 2.6	Spread to neighbouring buildings
Comment:	The system can meet this Standard, with reference to clauses 2.6.4 ⁽¹⁾⁽²⁾ , 2.6.5 ⁽¹⁾ and 2.6.6 ⁽²⁾ . See sections 8.1 to 8.4 of this Certificate.
Standard: 2.7	Spread on external walls
Comment:	The system can meet this Standard, and is acceptable for use more than one metre from a boundary, with reference to clauses 2.7.1 ⁽¹⁾⁽²⁾ and 2.7.2 ⁽²⁾ , and Annex 2A ⁽¹⁾ . See sections 8.1 to 8.4 of this Certificate.
Standard: 3.10	Precipitation
Comment:	The system can contribute to a construction satisfying this Standard, with reference to clauses 3.10.1 ⁽¹⁾⁽²⁾ and 3.10.2 ⁽¹⁾⁽²⁾ . See sections 4.4 and 10.1 of this Certificate.
Standard: 3.15	Condensation
Comment:	The system can contribute to satisfying this Standard, with reference to clauses 3.15.1 ⁽¹⁾⁽²⁾ , 3.15.4 ⁽¹⁾⁽²⁾ and 3.15.5 ⁽¹⁾⁽²⁾ . See sections 11.3 and 11.4 of this Certificate.
Standard: 6.1(b)	Carbon dioxide emissions
Standard: 6.2	Buildings insulation envelope
Comment:	The systems can contribute to satisfying these Standards, with reference to clauses (or parts of) 6.1.1 ⁽¹⁾ , 6.1.2 ⁽¹⁾⁽²⁾ , 6.1.3 ⁽¹⁾⁽²⁾ , 6.1.6 ⁽¹⁾ , 6.1.10 ⁽²⁾ , 6.2.1 ⁽¹⁾⁽²⁾ , 6.2.3 ⁽¹⁾ , 6.2.4 ⁽²⁾ , 6.2.6 ⁽¹⁾ , 6.2.7 ⁽¹⁾ , 6.2.8 ⁽²⁾ , 6.2.9 ⁽¹⁾⁽²⁾ , 6.2.10 ⁽¹⁾ , 6.2.11 ⁽¹⁾ , 6.2.12 ⁽²⁾ , and 6.2.13 ⁽¹⁾⁽²⁾ . See sections 6.2 and 6.3 of this Certificate.
Standard: 7.1(a)(b)	Statement of sustainability
Comment:	The system can contribute to satisfying the relevant requirements of Regulation 9, Standards 1 to 6, and therefore will contribute to a construction meeting the bronze level of sustainability as defined in this Standard. In addition, the system can contribute to a construction meeting a higher level of sustainability as defined in this Standard with reference to clauses 7.1.4 ⁽¹⁾⁽²⁾ [Aspect 1 ⁽¹⁾⁽²⁾ and 2 ⁽¹⁾], 7.1.6 ⁽¹⁾⁽²⁾ [Aspect 1 ⁽¹⁾⁽²⁾ and 2 ⁽¹⁾] and 7.1.7 ⁽¹⁾⁽²⁾ [Aspect 1 ⁽¹⁾⁽²⁾]. See section 6.2 of this Certificate.
Regulation: 12	Building standards applicable to conversions
Comment:	All comments given for the system under Regulation 9, Standards 1 to 6, also apply to this Regulation, with reference to clause 0.12.1 ⁽¹⁾⁽²⁾ and Schedule 6 ⁽¹⁾⁽²⁾ . (1) Technical Handbook (Domestic). (2) Technical Handbook (Non-Domestic).



The Building Regulations (Northern Ireland) 2012

Regulation:	23	Fitness of materials and workmanship
Comment:		The system is acceptable. See section 13.1 and the <i>Installation</i> part of this Certificate.
Regulation:	28	Resistance to moisture and weather
Comment:		Walls insulated with the system can satisfy this Regulation. See sections 4.4 and 10.1 of this Certificate.
Regulation:	29	Condensation
Comment:		Walls insulated with the system will satisfy the requirements of this Regulation. See section 11.4 of this Certificate.
Regulation:	30	Stability
Comment:		The system can sustain and transmit wind loads to the substrate wall. See section 7.4 of this Certificate.
Regulation:	36(a)	External fire spread
Comment:		The system has a low risk surface and can satisfy this Regulation. See sections 8.1 to 8.4 of this Certificate.
Regulation:	39(a)(i)	Conservation measures
Regulation:	40	Target carbon dioxide emission rate
Comment:		The system can contribute to satisfying these Regulations. See sections 6.2 and 6.3 of this Certificate.

Construction (Design and Management) Regulations 2007

Construction (Design and Management) Regulations (Northern Ireland) 2007

Information in this Certificate may assist the client, CDM co-ordinator, designer and contractors to address their obligations under these Regulations.

See section: 3 *Delivery and site handling* (3.1) of this Certificate.

Additional Information

NHBC Standards 2014

NHBC accepts the use of the TermoK8 Classico Minerale External Wall Insulating Render System, provided it is installed, used and maintained in accordance with this Certificate, in relation to *NHBC Standards, Part 6 Superstructure, Chapter 6.9 Curtain Walling and Cladding*.

Technical Specification

1 Description

1.1 The TermoK8 Classico Minerale External Wall Insulation System is an adhesively-fixed system with supplementary mechanical fixings, comprising mineral wool (MW) with reinforced, lightweight, coloured render (see Figure 1). The insulation slabs are primarily bonded to the external surfaces of the wall with a minimum of 30% coverage of adhesive, which is achieved after the slabs have been pressed against the wall; supplementary mechanical fixings are applied through the insulation slabs once the adhesive has fully set. Basecoat is applied to slabs to a uniform thickness, with the reinforcing mesh embedding immediately, and the surface smoothed with a trowel. A further layer of basecoat render is applied over the embedded reinforcing mesh to achieve the required overall thickness of 6mm. When the basecoat is dry, the selected finish is applied.

1.2 The components comprise:

Adhesive

- Klebocem/Klebocem Minerale — grey or white cement-based powder with a particle size of 0.6 mm, organic content of 3.1%, and mixed with 23% water by volume to form a paste. Used to fix the insulation slabs to the substrate to an approximate thickness of 10 mm.

Insulation

- mineral wool insulation slabs — 1200 mm by 600 mm slabs in a range of thicknesses from 40⁽¹⁾ mm to 260 mm with a nominal density of 75 kg·m⁻³, compressive strength of 25 kN·m⁻² and tensile strength perpendicular to the faces of 10 kN·m⁻². The slabs are manufactured to comply with the requirements of BS EN 13162 : 2012
- mineral wool lamella — mineral fibre slabs, in sizes up to 1200 mm by 200 mm and in thicknesses from 40 mm to 250 mm, with a nominal density of 85 kg·m⁻³, minimum compressive strength of 40 kN·m⁻², and a tensile strength perpendicular to the faces of 80 kN·m⁻². Slabs are manufactured to comply with BS EN 13162 : 2012.

(1) Slabs of 40 mm thickness are available for use in window reveals.

Supplementary mechanical fixings

TermoK8 fixings — a range of anchor plugs, with an anchorage depth of a least 25 mm, approved and supplied by the Certificate holder selected from (see section 5.6):

C1-CS — high-density polyethylene anchor sleeve with a metal centre pin

C1-CF — high-density polyethylene hammer-in anchor plugs with grip flanges

CT — high-density polyethylene anchor sleeve with metal centre pin

STRU — high-density polyethylene anchor sleeve with stainless steel centre pin

SDK U — high-density polyethylene anchor sleeve with steel centre pin
NTU — high-density polyethylene anchor sleeve with steel centre pin
H1 eco — high-density polyethylene anchor sleeve with steel centre pin

Basecoat

- Klebocem/Klebocem Minerale— grey or white cement-based powder with particle size of 0.6 mm, organic content 3.1%, and mixed with 24% water by volume to form a paste. Applied to a minimum overall thickness of 6 mm (applied in two coats).

Reinforcement

- Armatex C1 (standard)— a woven alkali-resistant glassfibre reinforcement mesh, cell size approximately 3.0 mm by 3.5 mm with a polymer coating and a nominal weight of 160 g·m⁻²
- Armatex C1 (reinforced) — a woven alkali-resistant glassfibre reinforcement mesh, cell size approximately 3.0 mm by 3.5 mm with a polymer coating and a nominal weight of 160 g·m⁻².

Finish

- TermoK8 Rivatone Plus G12/G15 — acrylic resin-based ready-to-use granular paste, applied to a thickness from 1.2 mm/1.5 (respectively) to a maximum of 3 mm, with a coverage rate of approximately 1 m² per 2.5 kg to 3.5 kg. Available in a range of colours
- TermoK8 Rivatone Idrosiliconico Plus G12/G15 — silicone resin-based ready-to-use granular paste, applied to a thickness from 1.2 mm/1.5 (respectively) to a maximum of 3 mm, with a coverage rate of approximately 1 m² per 2.5 kg to 3.5 kg. Available in a range of colours.

Figure 1 TermoK8 Classico Minerale External Wall Insulating Render System

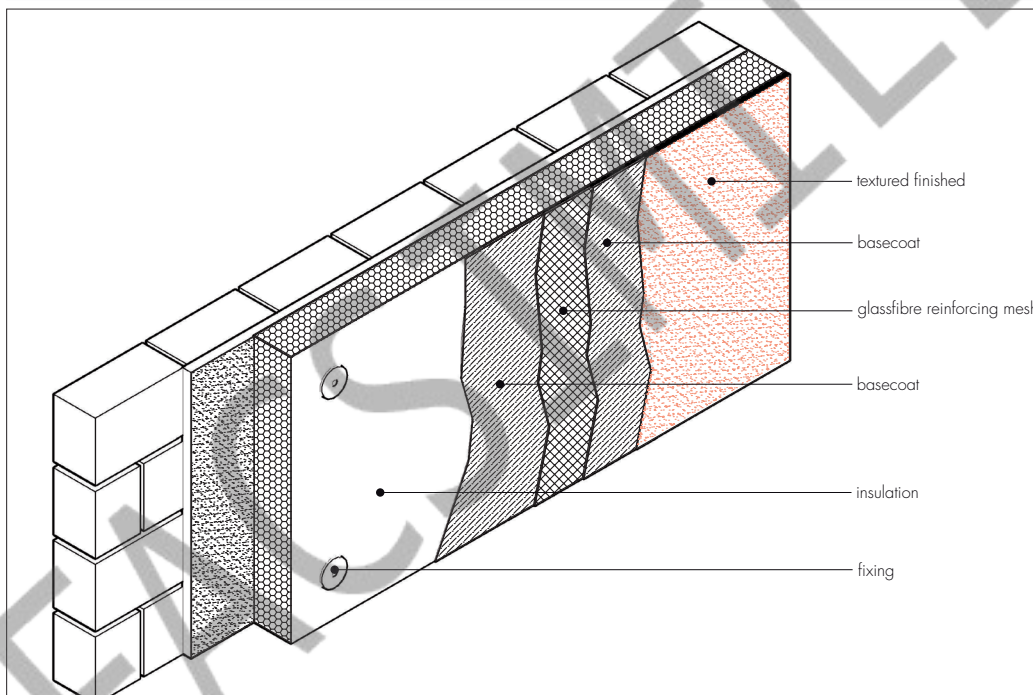

1.3 Ancillary materials also used with the systems but outside the scope of this Certificate:

- range of aluminium, PVC-U or stainless steel profiles, comprising:
 - base profile
 - edge profile
 - corner profile
 - render stop profile
 - movement and expansion joint
- profile connectors and fixings
- fungicidal wash, water-based masonry cleaner and steriliser containing biocides
- expansion foam
- sealants — silicone or mastic silicone in accordance with BS EN ISO 11600 : 2003
- mineral wool fire barrier
- cement or polymer-based mortar to repair the substrate surface.

2 Manufacture

2.1 Components are manufactured by the Certificate holder or bought in from suppliers, to an agreed specification.

2.2 As part of the assessment and ongoing surveillance of product quality, the BBA has:

- agreed with the manufacturer the quality control procedures and product testing to be undertaken
- assessed and agreed the quality control operated over batches of incoming materials
- monitored the production process and verified that it is in accordance with the documented process
- evaluated the process for management of nonconformities
- checked that equipment has been properly tested and calibrated
- undertaken to carry out the above measures on a regular basis through a surveillance process, to verify that the specifications and quality control operated by the manufacturer are being maintained.

2.3 The systems are marketed in the UK by: Aliva UK, 1210 Parkview, Arlington Business Park, Theale, Berkshire RG7 4TY. Tel: 01189 635 900, e-mail: enquiries@gruppovoivas.co.uk

3 Delivery and site handling

3.1 The insulation is delivered wrapped in polythene. The other components are delivered to site in the quantities and packaging listed in Table 1. Each package carries the product identification and manufacturer's batch number.

Table 1 Components — supply details⁽¹⁾

Component	Quantity
Klebocem/Klebocem Minerale adhesive	25 kg bag
Klebocem/Klebocem Minerale basecoat	25 kg bag
Armatex C1 reinforcing meshes	1 m x 50 m roll
TermoK8 Rivatone Plus G12/G15	25 kg plastic tub
TermoK8 Rivatone Idrosiliconico Plus G12/G15	25 kg plastic tub
Supplementary mechanical fixings	boxed by manufacturer

(1) Ancillary items, such as aluminium profiles or fixings are supplied boxed as appropriate.

3.2 The insulation should be stored on a firm, clean, level base, off the ground and under cover until required for use. Care must be taken when handling the insulation to avoid damage.

3.3 The powder components must be stored in a safe area, in dry conditions, off the ground and protected from moisture. Contaminated materials should be discarded.

Assessment and Technical Investigations

The following is a summary of the assessment and technical investigations carried out on the TermoK8 Classico Minerale External Wall Insulating Render System.

Design Considerations

4 General

4.1 The TermoK8 Classico Minerale External Wall Insulating Render System, when installed in accordance with this Certificate, is effective in reducing the thermal transmittance (U value) of the walls of new and existing buildings. It is essential that the detailing techniques specified in this Certificate are carried out to a high standard, if the ingress of water into the insulation is to be avoided and the full thermal benefit obtained from treatment with the systems.

4.2 For improved thermal/carbon-emissions performance, the designer should consider additional/alternative fabric and/or services measures.

4.3 The system is for application to the outside of external walls of masonry, or dense or no-fines concrete construction, on new or existing domestic and non-domestic buildings (with or without existing render) with no height restriction. Prior to installation of the system, wall surfaces should comply with section 14 of this Certificate.

4.4 New walls subject to national Building Regulations should be constructed in accordance with the relevant recommendations of:



- BS EN 1996-2 : 2006, in that the designer should select a construction appropriate to the local wind-driven rain index, paying due regard to the design detailing, workmanship and materials to be used
- BS 8000-3 : 2001.

4.5 Other new buildings not subject to regulatory requirements should also be built in accordance with the standards identified in section 4.4.

4.6 The system will improve the weather resistance of a wall and provide a decorative finish. However, it should only be installed where there are no signs of dampness on the inner surface of the wall other than those caused solely by condensation.

4.7 The effect of the installation of the insulation system on the acoustic performance of a construction is outside the scope of this Certificate.

4.8 The fixing of rainwater goods, satellite dishes, clothes lines, hanging baskets and similar items is outside the scope of this Certificate.

4.9 External plumbing should be removed before installation and alterations made to underground drainage, where appropriate, to accommodate repositioning of the plumbing to the finished face of the system.

4.10 It is essential that this system is installed and maintained in accordance with the conditions set out in this Certificate.

5 Practicability of installation

The system should only be installed by specialised contractors who have successfully undergone training and registration by the Certificate holder (see section 14).

Note: The BBA operates a UKAS Accredited Approved Installer Scheme for external wall insulation; details of approved installer companies are included on the BBA's website (www.bbacerts.co.uk).

6 Thermal performance

6.1 Calculations of thermal transmittance (U value) should be carried out in accordance with BS EN ISO 6946 : 2007 and BRE Report BR 443 : 2006, using the declared thermal conductivities values (λ_D) of the insulations given in Table 2.

Table 2 Declared thermal conductivities values (λ_D) and available thicknesses

Insulation type	Thickness (mm)	Thermal conductivity ($W \cdot m^{-1} \cdot K^{-1}$)
Mineral wool	40 to 260	0.036
MW lamella	40 to 200	0.042

6.2 The U value of a completed wall will depend on the insulation type and thickness, the type and number of fixings, and the insulating value of the substrate masonry and its internal finish. Calculated U values for sample construction in accordance with the national Building Regulations are given in Table 3, and are based on the thermal conductivities given in Table 2.

Table 3 Insulation thickness required to achieve design U values^{(1)|(2)|(3)}

U value ($W \cdot m^{-2} \cdot K^{-1}$) ⁽⁴⁾	Thickness of insulation (mm)			
	215 mm brickwork, $\lambda = 0.56 W \cdot m^{-1} \cdot K^{-1}$		200 mm dense blockwork, $\lambda = 1.75 W \cdot m^{-1} \cdot K^{-1}$	
	MW	MW lamella	MW	MW lamella
0.18	190	— ⁽⁵⁾	200	— ⁽⁵⁾
0.19	180	— ⁽⁵⁾	190	— ⁽⁵⁾
0.25	130	150	140	160
0.26	120	140	130	150
0.28	110	130	120	140
0.30	100	120	110	130
0.35	90	100	90	110

(1) Wall construction inclusive of 13 mm plaster ($\lambda = 0.57 W \cdot m^{-1} \cdot K^{-1}$, brickwork (protected) with 17.1% mortar or dense blockwork with 6.7% mortar ($\lambda = 0.88 W \cdot m^{-1} \cdot K^{-1}$). Declared thermal conductivity of insulation values (λ_D) is as shown in Table 2. An adhesive layer, 5 mm thick with $\lambda = 0.43 W \cdot m^{-1} \cdot K^{-1}$ covering 30% of the area is also included, and a board emissivity of 0.9, with an external render thickness of 5 mm with $\lambda = 1 W \cdot m^{-1} \cdot K^{-1}$.

(2) Calculations based on a system that included 4 galvanized steel fixings per square metre with a point thermal transmittance (X_p) of $0.002 W \cdot K^{-1}$ per steel pin. Use of other types of fixings should be calculated in accordance with BS EN ISO 6946 : 2007. A gap correction (ΔU) of zero is assumed.

(3) Based upon an incremental insulation thickness of 10 mm.

(4) When applying the maximum available insulation thickness, these walls can achieve U values from 0.14 to $0.20 W \cdot m^{-2} \cdot K^{-1}$ depending on insulation and wall type.

(5) See section 4.2.

6.3 The system can maintain, or contribute to maintaining, continuity of thermal insulation at junctions between external walls and other elements. Details shown in section 16 will allow use of the default ψ -values (Ψ_i) for Accredited Construction Details in Emission Rate calculations to SAP 2009 or the Simplified Building Energy Model (SBEM). Detailed guidance can be found in the documents supporting the national Building Regulations.

7 Strength and stability

General

7.1 When installed on suitable walls, the system can adequately transfer to the wall the self-weight and negative (suction) and positive (pressure) wind loads normally experienced in the United Kingdom.

7.2 Positive wind load is transferred to the substrate wall directly via bearing and compression of the render and insulation.

7.3 Negative wind pressure is resisted by the bond between each component. The insulation slabs are retained by the adhesive and supplementary fixings.

 7.4 The wind loads on the wall should be calculated in accordance with BS EN 1991-1-4 : 2005. Special consideration should be given to locations with high wind-load pressure coefficients, as additional fixings may be necessary. In accordance with BS EN 1990 : 2002, it is recommended that a load factor of 1.5 is used to determine the ultimate wind load to be resisted by the system.

7.5 Assessment of structural performance for individual installations should be carried out by a suitably qualified and experienced individual to confirm that:

- the substrate wall has adequate strength to resist the additional loads that may be applied as a result of installing the system, ignoring any positive contribution that may occur from the system
- the proposed system (with associated supplementary fixing layout) provides adequate resistance to negative wind loads
- an appropriate number of site-specific pull-off (bond strength) tests have been conducted on the substrate of the building to determine the minimum resistance to failure of the bond strength.

7.6 The bond strength between the adhesive and the substrate should be determined on site and taken as the mean of the five results divided by a safety factor of nine and multiplied by the minimum bond area.

7.7 The minimal admissible calculated bonded surface area (s) for the system is 30%⁽¹⁾, in accordance with ETAG 004 : 2013.

(1) This bonded area should be increased if the bond strength between the adhesive and the substrate is less than the ultimate wind load.

7.8 The initial adhesive bond between the insulation and the substrate will have a minimum failure resistance of 30 KN·m⁻². For calculating the design resistance, a minimum bonded area should be considered and a safety factor of nine applied.

7.9 The number of supplementary fixings, and the span between them, should be determined by the system designer. The mechanical fixings, which must be covered by an appropriate ETA, will initially transfer the weight of the system to the substrate wall. The fixing must be selected to give adequate support to the weight of the system at the minimum spacing.

Impact resistance

7.10 Hard body impact tests were carried out in accordance with ETAG 004 : 2013. The system is suitable for the use Categories listed in Table 4 of this Certificate.

Table 4 Thermok8 Classic External Wall Insulation System impact resistance

Rendering system: Basecoat + finishing coats indicated below	Category ⁽¹⁾	
	Single-layer mesh (standard mesh)	Single-layer mesh (reinforced mesh)
Klebocem/Klebocem Minerale + TermoK8 Rivatone Plus G12/G15	II	I
Klebocem/Klebocem Minerale + TermoK8 Rivatone Idrosiliconico Plus G12/15		

(1) The use categories are defined in ETAG 004 : 2013 as:

- Category I — a zone readily accessible at ground level to the public and vulnerable to hard body impacts but not subjected to abnormally rough use
- Category II — a zone liable to impacts from thrown or kicked objects, but in public locations where the height of the system will limit the size of the impact; or at lower levels where access to the building is primarily to those with some incentive to exercise care
- Category III — a zone not likely to be damaged by normal impacts caused by people or by thrown or kicked objects.

8 Behaviour in relation to fire

 8.1 The reaction to fire classification is A2-s1, d0 in accordance with BS EN 13501-1 : 2007.

 8.2 The fire classification applies to the full range of thicknesses and colours covered by this Certificate (when organic content of the basecoat and finishing coat is a maximum 3.1% and 9.4% respectively).

8.3 The insulation materials in isolation are classified as non-combustible.

8.4 The system is suitable for use on or at any distance from the boundary, without height restrictions.

8.5 For application to second storey walls and above, it is recommended that the design includes at least 1 stainless steel mechanical fixing per square metre, as advised in BRE Report BR 135 : 2013.

9 Proximity of flues and appliances

When the system is installed in close proximity to certain flue pipes, the relevant provisions of the national Building Regulations should be met:

10 Water resistance



10.1 The system will provide a degree of protection against water ingress. However, care should be taken to ensure that walls are adequately watertight prior to application of the system. The system must only be installed where there is no sign of dampness on the inner surface of the substrate other than that caused solely by condensation.

10.2 Designers and installers should take particular care in detailing around openings, penetrations and movement joints to minimise the risk of water ingress.

10.3 The guidance given in BRE Report BR 262 : 2002 should be followed in connection with the watertightness of solid wall constructions. The designer should select a construction appropriate to the local wind-driven index, paying due regard to the design detailing, workmanship and materials to be used.

10.4 At the top of walls, the system should be protected by an adequate overhang or other detail designed for use with this type of system (see section 16).

11 Risk of condensation



11.1 Designers must ensure that an appropriate condensation risk analysis has been carried out for all parts of the construction, including openings and penetrations at junctions between the insulation system and windows, to minimise the risk of condensation. The recommendations of BS 5250 : 2011 should be followed.

Surface condensation



11.2 Walls will adequately limit the risk of surface condensation when the thermal transmittance (U value) does not exceed $0.7 \text{ W}\cdot\text{m}^{-2}\cdot\text{K}^{-1}$ at any point and the junctions with other elements and openings comply with section 6.3 of this Certificate.



11.3 Walls will adequately limit the risk of surface condensation when the thermal transmittance (U value) does not exceed $1.2 \text{ W}\cdot\text{m}^{-2}\cdot\text{K}^{-1}$ at any point. Guidance may be obtained from BS 5250 : 2011, section 4 and Annex G, and BRE Report BR 262 : 2002.

Interstitial condensation



11.4 Walls incorporating the system will adequately limit the risk of interstitial condensation when they are designed and constructed in accordance with BS 5250 : 2011, section 4 and Annexes D and G.

11.5 The water vapour resistance factor (μ) and equivalent air layer thicknesses (s_d) are shown in Table 5 of this Certificate.

Table 5 Water vapour resistance factor (μ) and equivalent air layer thickness (s_d)

	Thickness (mm)	s_d (m)	μ
Mineral wool	40 to 260	–	1
Mineral wool lamella	40 to 250	–	1
Rendering system: Basecoat + finish coat, as indicated below			
Klebocem/Klebocem Minerale (4 mm) ⁽¹⁾ + TermoK8 Rivatone Plus G12 (1.2 mm) ⁽¹⁾	5.2 to 9	0.04	–
Klebocem/Klebocem Minerale (4 mm) ⁽¹⁾ + TermoK8 Rivatone Plus G15 (1.5 mm) ⁽¹⁾			
Klebocem/Klebocem Minerale (4 mm) ⁽¹⁾ + TermoK8 Rivatone Idrosiliconico Plus G12 (1.2 mm) ⁽¹⁾	5.2 to 9	0.02	–
Klebocem/Klebocem Minerale (4 mm) ⁽¹⁾ + TermoK8 Rivatone Idrosiliconico Plus G15 (1.5 mm) ⁽¹⁾		0.05	

(1) tested to this.

12 Maintenance and repair



12.1 Regular checks should be made on the installed system, including:

- visual inspection of the render for signs of damage. Cracks in the render exceeding 0.2 mm must be repaired
- examination of the sealant around openings and service entry points
- visual inspection of architectural details designed to shed water to confirm that they are performing properly
- visual inspection to ensure that water is not leaking from external downpipes or gutters; such leakage could penetrate the rendering

- necessary repairs effected immediately and the sealant joints at window and door frames replaced at regular intervals
- maintenance schedules, which should include the replacement and resealing of joints, for example between the insulation system and window and door frame.

12.2 Damaged areas must be repaired using the appropriate components and procedures detailed in the Certificate holder's installation instructions and in accordance with BS EN 13914-1 : 2005.

13 Durability

 13.1 The system will remain effective for at least 30 years provided any damage to the surface finish is repaired immediately and regular maintenance is undertaken, as described in Section 12.

13.2 Any render containing cement may be subject to lime bloom. The occurrence of this may be reduced by avoiding application in adverse weather conditions. The effect is transient and less noticeable on lighter colours.

13.3 The render may become discoloured with time, the rate depending on the initial colour, the degree of exposure and atmospheric pollution, as well as the design and detailing of the wall. In common with traditional renders, discoloration by algae and lichens may occur in wet areas. The appearance may be restored by a suitable power wash or, if required, by over coating.

13.4 To maintain a high quality aesthetic appearance, it may be necessary to periodically overcoat the building using a suitable masonry coating (ie one covered by a valid BBA Certificate for this purpose). Care should be taken not to adversely affect the water vapour transmission or fire characteristics of the system. The advice of the Certificate holder should be sought as to the suitability of a particular product.

Installation

14 Site survey and preliminary work

14.1 A pre-installation survey of the property must be carried out to determine suitability for treatment and the need for any necessary repairs to the building structure before application of the system. A specification is prepared for each elevation of the building indicating:

- additional corner mesh and reinforcement, where required
- the position of beads
- detailing around windows, doors and at eaves
- damp-proof course (dpc) level (not covered by this Certificate)
- exact position of expansion joints
- areas where flexible sealants must be used.

14.2 The survey should include tests conducted on the walls of the building by the Certificate holder or their approved installers to determine the pull-out resistance of the proposed supplementary mechanical fixings. An assessment and recommendation is made on the type and number of fixings required to withstand the building's expected wind loading based on calculations using the test data and pull-out resistance (see section 7).

14.3 All necessary repairs to the building structure must be completed before installation of the system commences.

14.4 Surfaces should be sound, clean, and free from loose material. The flatness of surfaces must be checked; this may be achieved using a straight-edge spanning the storey height. Any excessive irregularities, ie greater than 20 mm, must be made good prior to installation, to ensure that the insulation slabs are installed with a smooth, in-plane finished surface.

14.5 Where surfaces are covered with an existing rendering, it is essential that the bond between the background and the render is adequate. All loose areas should be hacked off and reinstated.

14.6 On existing buildings, purpose-made sills must be fitted to extend beyond the finished face of the system. New buildings should incorporate suitably deep sills.

14.7 Internal wet work, eg screeding or plastering, should be completed and allowed to dry prior to the application of a system.

15 Approved installers

Application of the system, within the context of this Certificate, must be carried out by installers approved by the Certificate holder. A Certificate holder approved installer is a company:

- employing operatives who have been trained and approved by the Certificate holder to install the system
- which has undertaken to comply with the Certificate holder's application procedure, containing the requirement for each application team to include at least one member operative trained by the Certificate holder
- subject to at least one inspection per annum by the Certificate holder to ensure suitable site practices are being employed. This may include unannounced site inspections.

16 Procedure

General

16.1 Installation of the systems is carried out in accordance with the Certificate holder's installation instructions.

16.2 Weather conditions should be monitored to ensure that the circumstances under which application and curing of the systems take place are favourable. Application of the mortar and finishes should not be carried out at temperatures below 5°C or above 35°C, or if exposure to frost is likely. The coating must be protected from rapid drying.

16.3 The planarity and condition of the substrate must be checked, and any protrusions exceeding 10 mm removed.

16.4 All rendering should be in accordance with the relevant recommendations of BS EN 13914-1 : 2005.

Positioning and securing insulation slabs

16.5 The supporting base profile is secured to the external wall above the dpc using approved profile fixings at 400 mm maximum centres (See Figure 2). Base rail connectors are inserted at all rail joints. Extension profiles should be fixed to the front lip of the base rail or stop end channel where appropriate.

Figure 2 Typical section of base profile

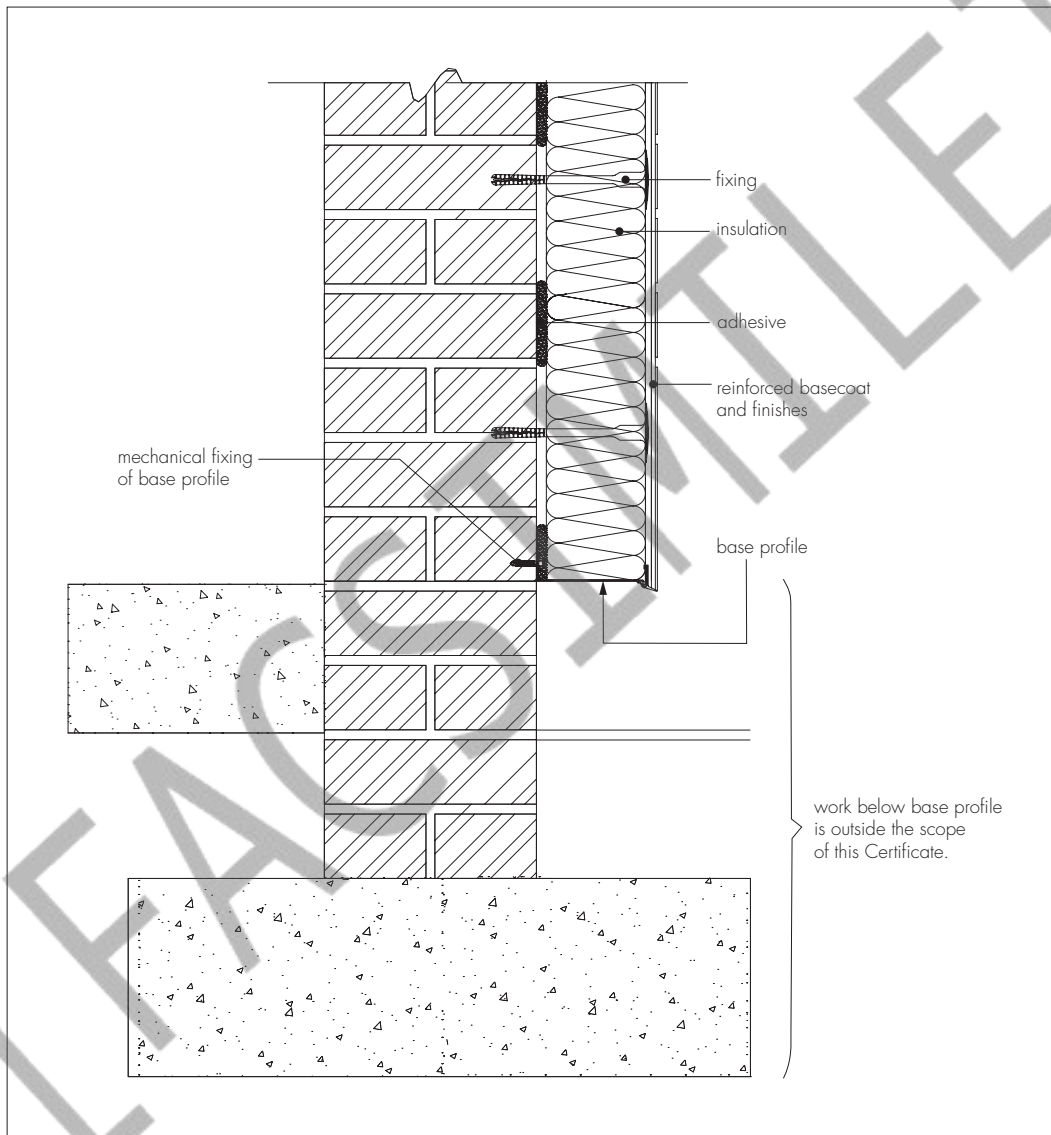

16.6 The adhesive is prepared with the required amount of water (see section 1), and mixed with a paddle mixer until the desired consistency is achieved. After allowing the adhesive to rest for 5 minutes, it is applied in a continuous bordering strip around the perimeter of the board with three additional dabs of approximate width between 10 mm and 40 mm distributed uniformly over the remaining surface. Alternatively, a serrated edge trowel with 5 mm serrations can be used to apply the adhesive to the entire rear surface of the insulation board (see Figure 3). The amount of adhesive applied should cover at least 30% of the slab, after slabs have been pressed against the wall.

Figure 3 Insulation slabs adhesive pattern

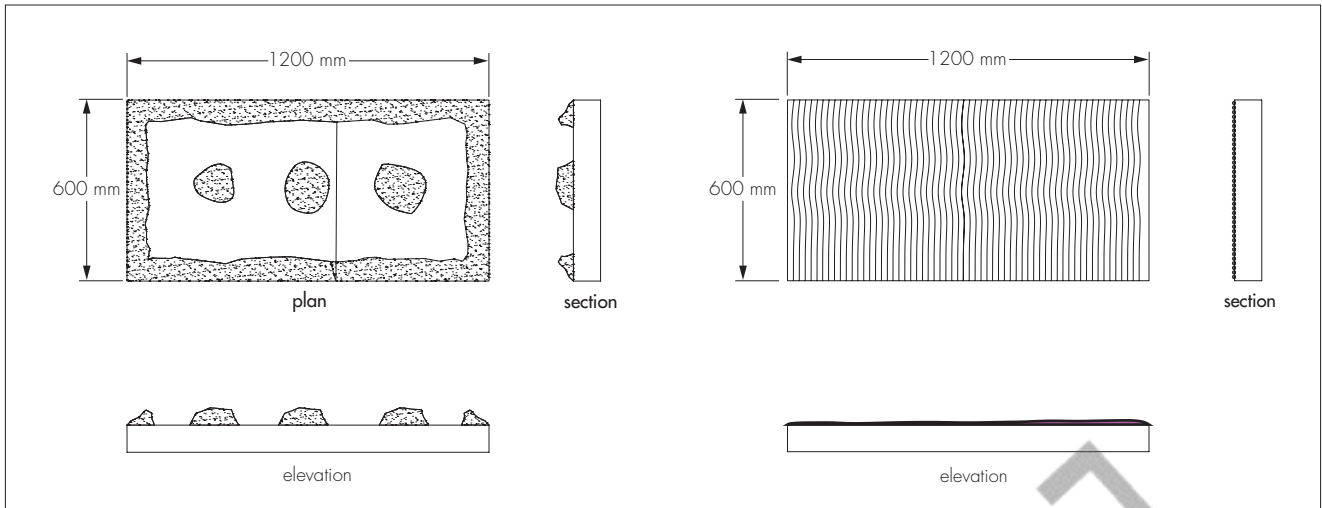

16.7 The first run of insulation slabs is positioned on the base profile with the adhesive applied. The slabs must be pressed firmly against the wall and butted tightly together and aligned to achieve a level finish. Subsequent rows of slabs are positioned so that the vertical board joints are staggered and overlapped at the building corners and so that the board joints do not occur within 200 mm of the corners of openings (see Figure 4). Joints between slabs greater than 2 mm should be filled with slivers of insulation board or low density polyurethane foam. Gaps greater than 10 mm should be closed by repositioning or, where appropriate, by cutting slabs to fit. Any high spots or irregularities should be removed. Alignment should be checked as work proceeds.

Figure 4 Typical arrangement of insulation slabs

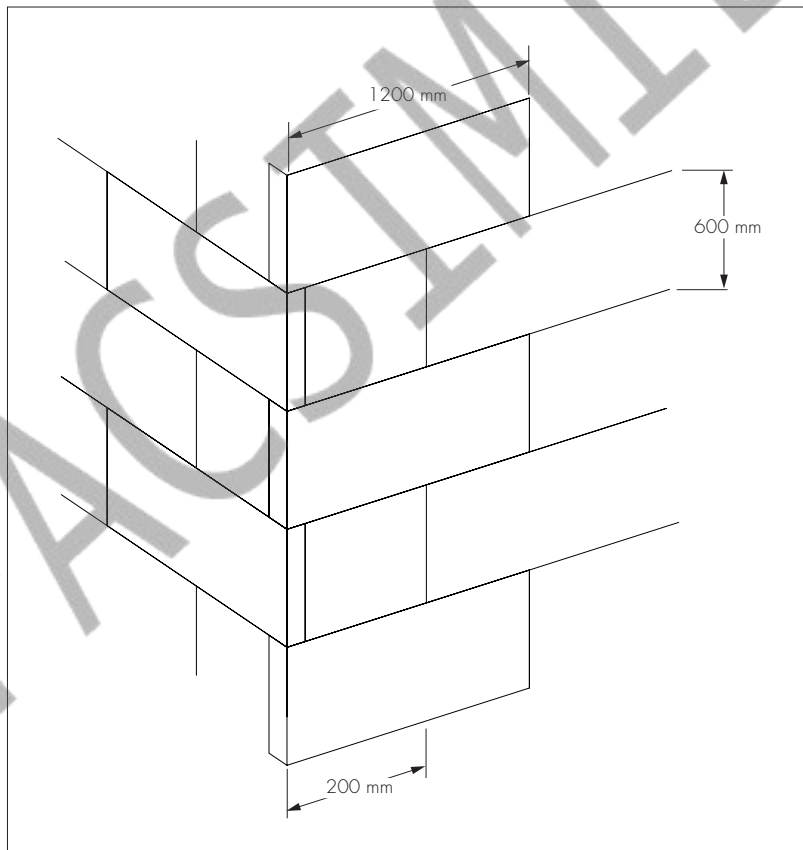

16.8 If supplementary fixings are deemed to be necessary, a minimum of three mechanical fixings in a 'saltire' fixing pattern (equivalent to four fixings per m²) is applied through the insulation board into the substrate wall to prevent the panels from collapsing or moving while the adhesive sets, but appropriate structural calculations should be undertaken by a competent person.

16.9 To fit around details such as doors and windows, insulation slabs may be cut with a sharp knife or a fine toothed saw. If required, purpose-made window-sills are fitted at this stage. They are designed to prevent water ingress and incorporate drips to shed water clear of the system.

16.10 Installation continues until the whole wall is completely covered including, where appropriate, the building soffits.

16.11 Window and door reveals should be insulated to minimise the effects of cold bridging. Where clearance is limited, strips of approved insulation should be installed to suit available margins and details.

16.12 Prior to the application of the render system, a bead of joint sealant is gun-applied at window and door frames, overhanging eaves, gas and electric meter boxes, and wall vents, or where the render abuts any other building material or surface.

Movement joints

16.13 Generally, movement joints are not required in the system but, if an expansion joint is already incorporated in the substrate, a movement joint must be included with the system (see Figure 5). Specific types of joint have not been assessed as part of this system and advice should be sought from the Certificate holder.

Figure 5 Typical movement joint

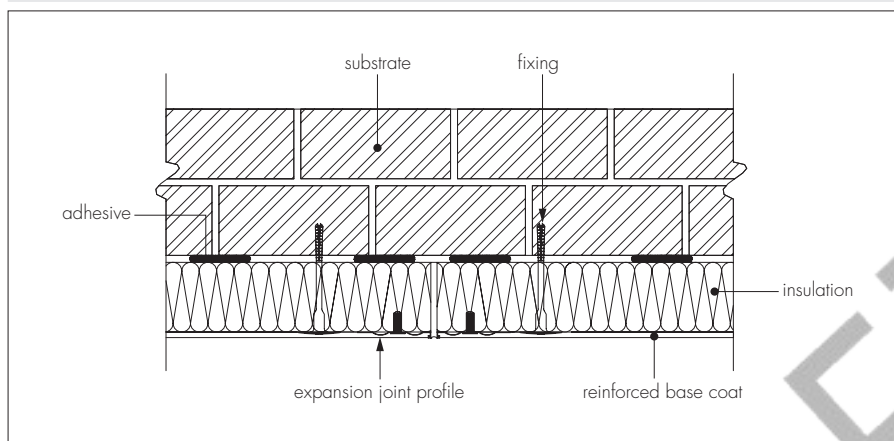

Application of basecoat and reinforcement mesh

16.14 Prior to the application of reinforcing mesh, diagonal reinforcing patches (approximate size 350 mm by 250 mm) are embedded at the corners of windows and doors and other building openings so that they extend equally either side of the corner (see Figure 6).

Figure 6 Reinforcement at openings

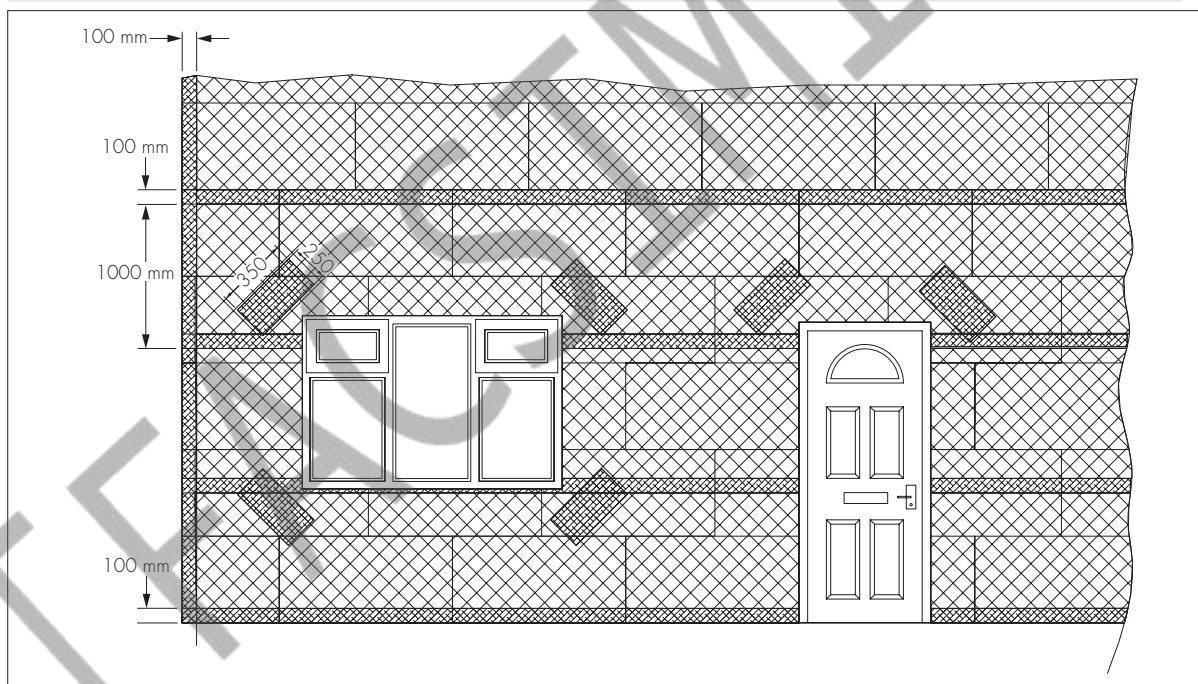

16.15 The basecoat is prepared with the required amount of water (see section 1) then applied over the insulation slabs using a stainless steel trowel, and floated with a Darby float to an approximate thickness of 3 mm. The reinforcement mesh is immediately embedded into the basecoat by trowelling from the centre to the edge and an additional light coat of basecoat is applied (whilst the first coat is still wet) to ensure the mesh is free of wrinkles; overlapping at all mesh joints should not be less than 100 mm.

16.16 Further basecoat is then applied as required, to ensure the mesh is completely covered and the required minimum overall thickness of basecoat is achieved (6 mm). The overall thickness of the reinforced basecoat must not be greater than 10 mm.

16.17 The basecoat is applied progressively, working in one-metre sections in a vertical or horizontal direction.

16.18 Stop beads are positioned vertically, eg at party wall positions where the adjoining house does not require treatment. Where required, angle beads are fixed to all building corners and to door and window heads and jambs.

16.19 The basecoat should be thoroughly dry before application of the finish coat. The drying time will depend upon the conditions, but at least 48 hours should elapse.

Finishing

16.20 Prior to the finish coats, a bead of clear silicone sealant is gun-applied at window and door frames, overhanging eaves, gas and electrical meter boxes, wall vents or where the render abuts other building materials or surfaces.

16.21 The finish coating must be trowel- or roller-applied to give the appropriate texture effect.

16.22 The render finishes are applied to the required thicknesses (see section 1), using a stainless steel trowel and finished with a plastic trowel to create a textured finish. The drying time is dependent on conditions but will typically be 48 hours, in accordance with the Certificate holder's instructions.

16.23 To prevent the finish from drying too rapidly, it should not be applied in direct sunlight. The finished render surface must be protected from rain and frost until the material is dry. Continuous surfaces must be completed without a break, eg working to a wet edge.

16.24 At the top of walls, the system should be protected by an adequate overhang (see Figure 7) or by an adequately sealed, purpose-made flashing. Care should be taken in the detailing of the system around openings and projections (see Figures 8, 9 and 10).

Figure 7 Typical roof eaves detail

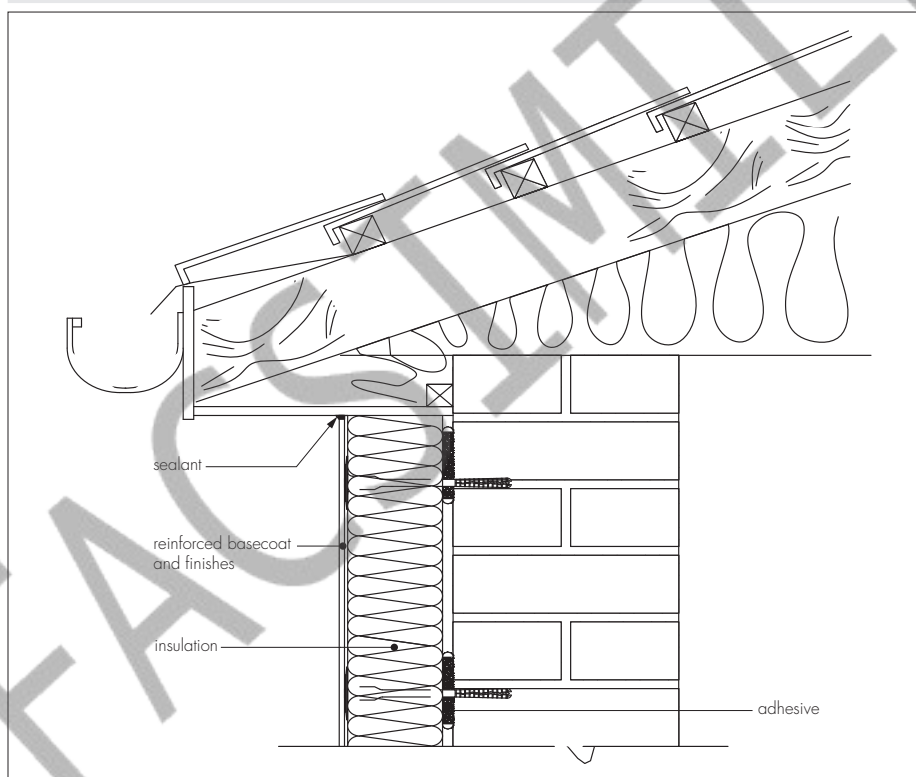

Figure 8 Window head details

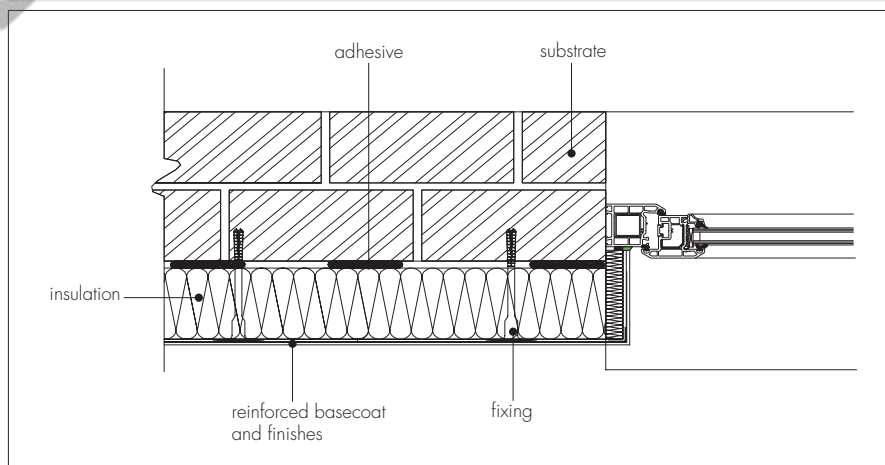

Figure 9 Corner details

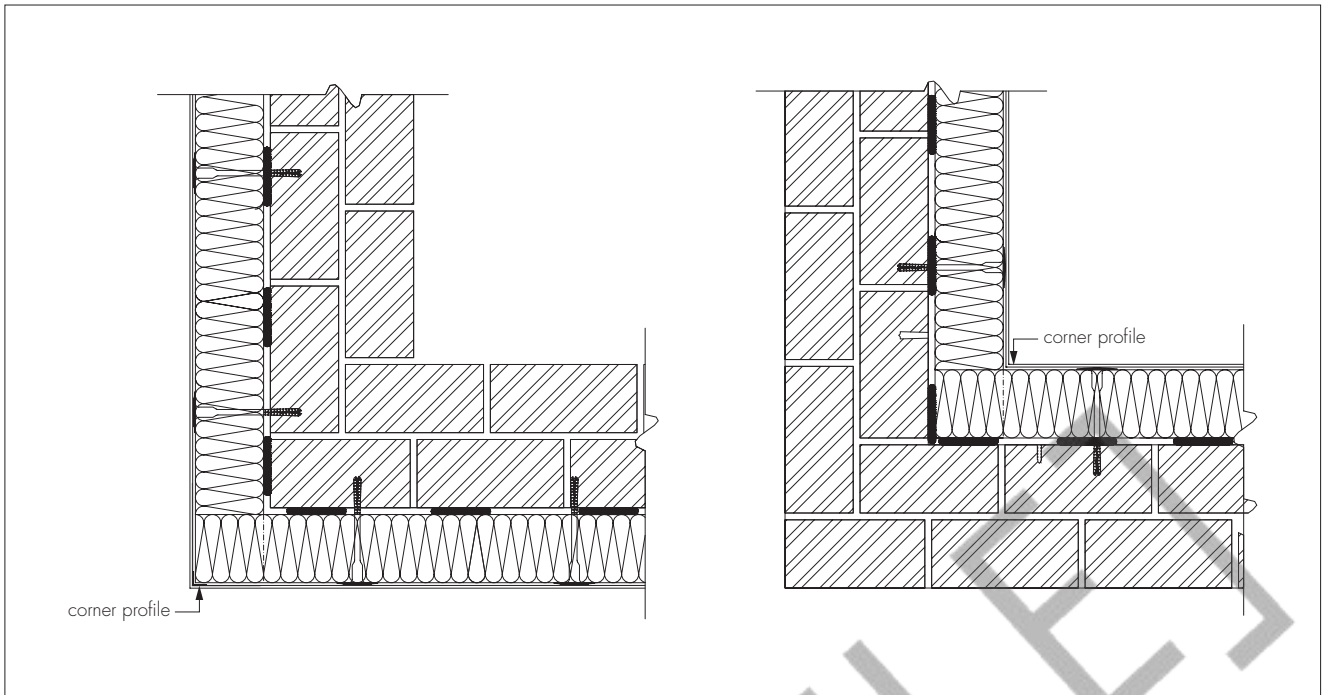
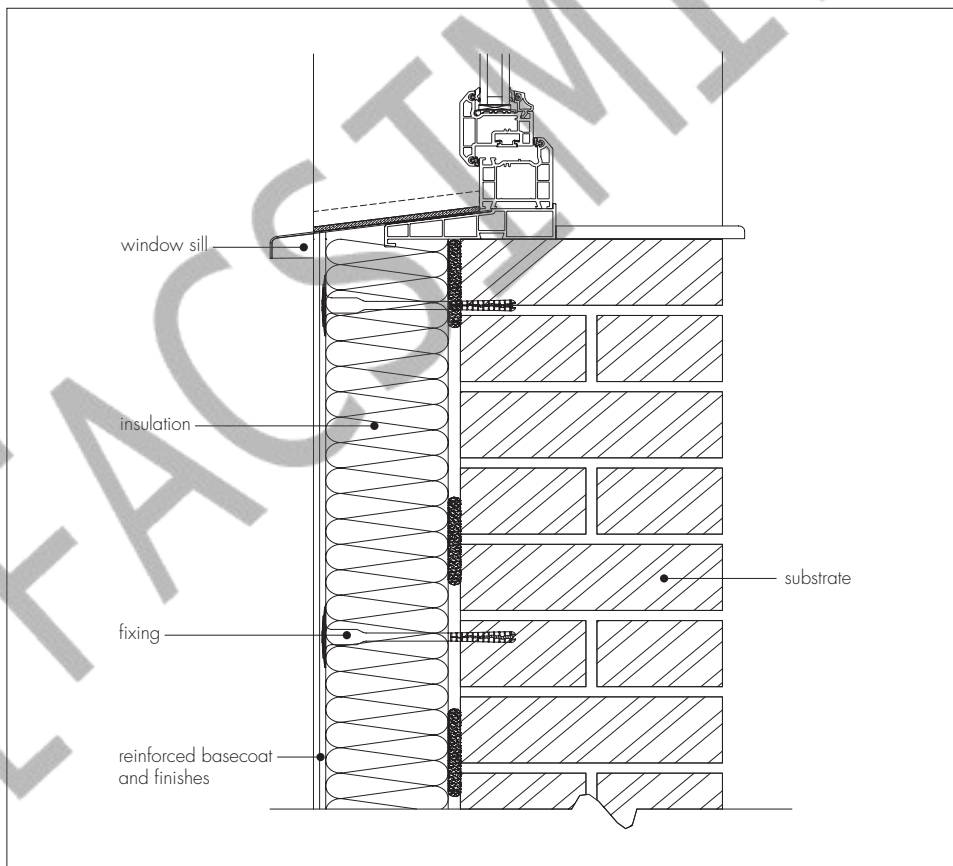

Figure 10 Window sill details



16. 25 On completion of the installation, external fittings, eg rainwater goods, are re-fixed through the system into the substrate.

17 Tests

17.1 An examination was made of data relating to:

- reaction-to-fire class in accordance with BS EN 13501-1 : 2007
- bond strength
- hygrothermal performance
- resistance to frost
- resistance to impact
- water vapour permeability.
- thermal conductivity
- the risk of interstitial condensation.

17.2 The practicability of installation and the effectiveness of detailing techniques were examined.

17.3 The manufacturing process was evaluated, including the methods adopted for quality control, and details were obtained of the quality and composition of materials used.

Bibliography

BS 5250 : 2011 *Code of practice for control of condensation in buildings*

BS 8000-3 : 2001 *Workmanship on building sites — Code of practice for masonry*

BS EN 1990 : 2002 *Eurocode — Basis of structural design*

BS EN 1991-1-4 : 2005 *Eurocode 1 : Actions on structures — General actions — Wind actions*

BS EN 1996-2 : 2006 *Eurocode 6 — Design of masonry structures — Design considerations, selection of materials and execution of masonry*

BS EN 13162 : 2012 *Thermal insulation products for buildings — Factory made mineral wool (MW) products — Specification*

BS EN 13501-1 : 2007 *Fire classification of construction products and building elements — Classification using test data from reaction to fire tests*

BS EN 13914-1 : 2005 *Design, preparation and application of external rendering and internal plastering — External rendering*

BS EN ISO 11600 : 2013 *Building construction — Jointing products — Classification and requirements for sealants*

BS EN ISO 6946 : 2007 *Building components and building elements — Thermal resistance and thermal transmittance — Calculation method*

BRE Report (BR 262 : 2002) *Thermal insulation: avoiding risks*

BRE Report (BR 443 : 2006) *Conventions for U-value calculations*

ETAG 004 : 2013 *Guideline for European Technical Approval of External Thermal Insulation Composite Systems with Rendering*

18 Conditions

18.1 This Certificate:

- relates only to the product/system that is named and described on the front page
- is issued only to the company, firm, organisation or person named on the front page — no other company, firm, organisation or person may hold or claim that this Certificate has been issued to them
- is valid only within the UK
- has to be read, considered and used as a whole document — it may be misleading and will be incomplete to be selective
- is copyright of the BBA
- is subject to English Law.

18.2 Publications, documents, specifications, legislation, regulations, standards and the like referenced in this Certificate are those that were current and/or deemed relevant by the BBA at the date of issue or reissue of this Certificate.

18.3 This Certificate will remain valid for an unlimited period provided that the product/system and its manufacture and/or fabrication, including all related and relevant parts and processes thereof:

- are maintained at or above the levels which have been assessed and found to be satisfactory by the BBA
- continue to be checked as and when deemed appropriate by the BBA under arrangements that it will determine
- are reviewed by the BBA as and when it considers appropriate.

18.4 The BBA has used due skill, care and diligence in preparing this Certificate, but no warranty is provided.

18.5 In issuing this Certificate, the BBA is not responsible and is excluded from any liability to any company, firm, organisation or person, for any matters arising directly or indirectly from:

- the presence or absence of any patent, intellectual property or similar rights subsisting in the product/system or any other product/system
- the right of the Certificate holder to manufacture, supply, install, maintain or market the product/system
- actual installations of the product/system, including their nature, design, methods, performance, workmanship and maintenance
- any works and constructions in which the product/system is installed, including their nature, design, methods, performance, workmanship and maintenance
- any loss or damage, including personal injury, howsoever caused by the product/system, including its manufacture, supply, installation, use, maintenance and removal
- any claims by the manufacturer relating to CE marking.

18.6 Any information relating to the manufacture, supply, installation, use, maintenance and removal of this product/system which is contained or referred to in this Certificate is the minimum required to be met when the product/system is manufactured, supplied, installed, used, maintained and removed. It does not purport in any way to restate the requirements of the Health and Safety at Work etc. Act 1974, or of any other statutory, common law or other duty which may exist at the date of issue or reissue of this Certificate; nor is conformity with such information to be taken as satisfying the requirements of the 1974 Act or of any statutory, common law or other duty of care.