

## I.V.A.S Industria Vernici S.p.A

Via Bellaria, 40  
I-47030  
San Mauro Pascoli (FC), Italy

Tel: 01189 635 900 Fax: 01189 635 901

e-mail: [enquiries@gruppoivas.co.uk](mailto:enquiries@gruppoivas.co.uk)

website: [www.gruppoivas.com](http://www.gruppoivas.com)



**Agrément Certificate**

**11/4841**

Product Sheet 4

### TERMOK8 EXTERNAL WALL INSULATION SYSTEMS

### TERMOK8 MINERALE EXTERNAL WALL INSULATING RENDER SYSTEMS

This Agrément Certificate Product Sheet<sup>(1)</sup> relates to TermoK8 Minerale External Wall Insulating Render Systems, comprising mechanically fixed mineral wool dual density (MWDD) or mineral wool lamella insulation slabs, with supplementary adhesive, reinforced basecoat and either render or brick slip finishes. The systems are suitable for use on the outside of masonry external walls in new or existing domestic and non-domestic buildings.

(1) Hereinafter referred to as 'Certificate'.

#### CERTIFICATION INCLUDES:

- factors relating to compliance with Building Regulations where applicable
- factors relating to additional non-regulatory information where applicable
- independently verified technical specification
- assessment criteria and technical investigations
- design considerations
- installation guidance
- regular surveillance of production
- formal three-yearly review.



#### KEY FACTORS ASSESSED

**Thermal performance** — the systems can be used to improve the thermal performance of external walls and can contribute to satisfying the requirements of the national Building Regulations (see section 6).

**Strength and stability** — the systems can be designed to resist the wind loads experienced for a particular location, and have adequate impact resistance. The impact resistance is dependent on the system chosen (see section 7).

**Behaviour in relation to fire** — the systems can have reaction to fire classifications of A2-s1, d0 or A1 in accordance with BS EN 13501-1 : 2018 depending on the system chosen (see section 8).

**Condensation** — the systems can contribute to limiting the risk of interstitial and surface condensation (see section 11).

**Durability** — when installed and maintained in accordance with the Certificate holder's recommendations and the terms of this Certificate, the systems will remain effective for at least 30 years. The durability can be extended to 60 years, except for systems incorporating clay/ceramic brick slip finishes, by using different fixings and by following a planned inspection and effective maintenance schedule (see sections 12 and 13).

The BBA has awarded this Certificate to the company named above for the systems described herein. These systems have been assessed by the BBA as being fit for their intended use provided they are installed, used and maintained as set out in this Certificate.

On behalf of the British Board of Agrément

Date of Fourth issue: 28 January 2022

Originally certificated on 18 December 2014

Hardy Giesler  
Chief Executive Officer

*The BBA is a UKAS accredited certification body – Number 113.*

*The schedule of the scope of accreditation for product certification is available in pdf format via the UKAS link on the BBA website at [www.bbacerts.co.uk](http://www.bbacerts.co.uk)  
Readers MUST check the validity and latest issue number of this Agrément Certificate by either referring to the BBA website or contacting the BBA directly.*

*Any photographs are for illustrative purposes only, do not constitute advice and should not be relied upon.*

#### British Board of Agrément

Bucknalls Lane  
Watford  
Herts WD25 9BA

tel: 01923 665300  
[clientservices@bbacerts.co.uk](mailto:clientservices@bbacerts.co.uk)  
[www.bbacerts.co.uk](http://www.bbacerts.co.uk)

©2022

## Regulations

In the opinion of the BBA, TermoK8 Minerale External Wall Insulating Render Systems, if installed, used and maintained in accordance with the provisions of this Certificate, can satisfy, or contribute to satisfying, the relevant requirements of the following Building Regulations (the presence of a UK map indicates that the subject is related to the Building Regulations in the region or regions of the UK depicted):



### The Building Regulations 2010 (England and Wales) (as amended)

<b>Requirement:</b> A1	<b>Loading</b>
Comment:	The systems can sustain and transmit wind loads to the substrate wall. See sections 7.1 to 7.12 of this Certificate.
<b>Requirement:</b> B4(1)	<b>External fire spread</b>
Comment:	The systems may be unrestricted by this Requirement. See sections 8.1 to 8.7 of this Certificate.
<b>Requirement:</b> C2(b)	<b>Resistance to moisture</b>
Comment:	The systems provide a degree of protection against rain ingress. See section 10.1 of this Certificate.
<b>Requirement:</b> C2(c)	<b>Resistance to moisture</b>
Comment:	The systems can contribute to minimising the risk of interstitial and surface condensation. See sections 11.2, 11.3 and 11.5 of this Certificate.
<b>Requirement:</b> L1(a)(i)	<b>Conservation of fuel and power</b>
Comment:	The systems can contribute to satisfying this Requirement. See sections 6.1 and 6.2 of this Certificate.
<b>Regulation:</b> 7(1)	<b>Materials and workmanship</b>
Comment:	The systems are acceptable. See sections 13.1 and 13.2 and the <i>Installation</i> part of this Certificate.
<b>Regulation:</b> 7(2)	<b>Materials and workmanship</b>
Comment:	The systems may be unrestricted by this Regulation. See sections 8.1 to 8.7 of this Certificate.
<b>Regulation:</b> 26	<b>CO<sub>2</sub> emission rate for new buildings</b>
<b>Regulation:</b> 26A	<b>Fabric energy efficiency rates for new dwellings (applicable to England only)</b>
<b>Regulation:</b> 26A	<b>Primary energy consumption rates for new buildings (applicable to Wales only)</b>
<b>Regulation:</b> 26B	<b>Fabric performance values for new dwellings (applicable to Wales only)</b>
Comment:	The systems can contribute to satisfying these Regulations. See sections 6.1 and 6.2 of this Certificate.



### The Building (Scotland) Regulations 2004 (as amended)

<b>Regulation:</b> 8(1)(2)	<b>Durability, workmanship and fitness of materials</b>
Comment:	The systems can contribute to satisfying this Regulation. See sections 12, 13.1 and 13.2 and the <i>Installation</i> part of this Certificate.
<b>Regulation:</b> 9	<b>Building standards applicable to construction</b>
Standard: 1.1	Structure
Comment:	The systems can sustain and transmit wind loads to the substrate wall. See sections 7.1 to 7.12 of this Certificate.

Standard:	2.6	Spread to neighbouring buildings
Comment:		The systems may be unrestricted by this Standard, with reference to clauses 2.6.4 <sup>(1)(2)</sup> , 2.6.5 <sup>(1)</sup> and 2.6.6 <sup>(2)</sup> . See sections 8.1 to 8.7 of this Certificate.
Standard:	2.7	Spread on external walls
Comment:		The systems may be unrestricted by this Standard, with reference to clause 2.7.1 <sup>(1)(2)</sup> . See sections 8.1 to 8.7 of this Certificate.
Standard:	3.10	Precipitation
Comment:		The systems can contribute to satisfying this Standard, with reference to clauses 3.10.1 <sup>(1)(2)</sup> and 3.10.2 <sup>(1)(2)</sup> . See section 10.1 of this Certificate.
Standard:	3.15	Condensation
Comment:		The systems can contribute to satisfying this Standard, with reference to clauses 3.15.1 <sup>(1)(2)</sup> , 3.15.4 <sup>(1)(2)</sup> and 3.15.5 <sup>(1)(2)</sup> . See sections 11.2, 11.4 and 11.5 of this Certificate.
Standard:	6.1(b)	Carbon dioxide emissions
Standard:	6.2	Buildings insulation envelope
Comment:		The systems can contribute to satisfying these Standards, with reference to clauses, or parts of, 6.1.1 <sup>(1)</sup> , 6.1.2 <sup>(1)(2)</sup> , 6.1.3 <sup>(1)(2)</sup> , 6.1.6 <sup>(1)</sup> , 6.1.10 <sup>(2)</sup> , 6.2.1 <sup>(1)(2)</sup> , 6.2.3 <sup>(1)</sup> , 6.2.4 <sup>(2)</sup> , 6.2.5 <sup>(2)</sup> , 6.2.6 <sup>(1)</sup> , 6.2.7 <sup>(1)</sup> , 6.2.8 <sup>(2)</sup> , 6.2.9 <sup>(1)(2)</sup> , 6.2.10 <sup>(1)</sup> , 6.2.11 <sup>(1)</sup> , 6.2.12 <sup>(2)</sup> and 6.2.13 <sup>(1)(2)</sup> . See sections 6.1 and 6.2 of this Certificate.
Standard:	7.1(a)(b)	Statement of sustainability
Comment:		The systems can contribute to satisfying the relevant requirements of Regulation 9, Standards 1 to 6, and therefore will contribute to a construction meeting the bronze level of sustainability as defined in this Standard. In addition, the systems can contribute to a construction meeting a higher level of sustainability as defined in this Standard with reference to clauses 7.1.4 <sup>(1)(2)</sup> [Aspect 1 <sup>(1)(2)</sup> and 2 <sup>(1)</sup> ], 7.1.6 <sup>(1)(2)</sup> [Aspect 1 <sup>(1)(2)</sup> and 2 <sup>(1)</sup> ] and 7.1.7 <sup>(1)(2)</sup> [Aspect 1 <sup>(1)(2)</sup> ]. See section 6.1 of this Certificate.
<b>Regulation:</b>	<b>12</b>	<b>Building standards applicable to conversions</b>
Comment:		All comments given for the systems under Regulation 9, Standards 1 to 6, also apply to this Regulation, with reference to clause 0.12.1 <sup>(1)(2)</sup> and Schedule 6 <sup>(1)(2)</sup> .

(1) Technical Handbook (Domestic).

(2) Technical Handbook (Non-Domestic).



## The Building Regulations (Northern Ireland) 2012 (as amended)

<b>Regulation:</b>	<b>23</b>	<b>Fitness of materials and workmanship</b>
Comment:		The systems are acceptable. See sections 13.1 and 13.2 and the <i>Installation</i> part of this Certificate.
<b>Regulation:</b>	<b>28(b)</b>	<b>Resistance to moisture and weather</b>
Comment:		Walls insulated with the systems can satisfy this Regulation. See section 10.1 of this Certificate.
<b>Regulation:</b>	<b>29</b>	<b>Condensation</b>
Comment:		Walls insulated with the systems will satisfy the requirements of this Regulation. See sections 11.2 and 11.5 of this Certificate.
<b>Regulation:</b>	<b>30</b>	<b>Stability</b>
Comment:		The systems can sustain and transmit wind loads to the substrate wall. See sections 7.1 to 7.12 of this Certificate.
<b>Regulation:</b>	<b>36(a)</b>	<b>External fire spread</b>
Comment:		The systems may be unrestricted by this Regulation. See sections 8.1 to 8.7 of this Certificate.

<b>Regulation:</b>	<b>39(a)(i)</b>	<b>Conservation measures</b>
<b>Regulation:</b>	<b>40</b>	<b>Target carbon dioxide emission rate</b>
<b>Comment:</b>	The systems can contribute to satisfying these Regulations. See sections 6.1 and 6.2 of this Certificate.	

## Construction (Design and Management) Regulations 2015 Construction (Design and Management) Regulations (Northern Ireland) 2016

Information in this Certificate may assist the client, designer (including Principal Designer) and contractor (including Principal Contractor) to address their obligations under these Regulations.

See sections: 3 *Delivery and site handling* (3.1) and 12 *Maintenance and repair* of this Certificate.

### Additional Information

#### NHBC Standards 2022

In the opinion of the BBA, Termok8 Minerale External Wall Insulating Render Systems, if installed, used and maintained in accordance with this Certificate, can satisfy or contribute to satisfying the relevant requirement in relation to *NHBC Standards, Part 6 Superstructure (excluding roofs), Chapter 6.9 Curtain walling and cladding*.

### Technical Specification

#### 1 Description

1.1 Termok8 Minerale External Wall Insulating Render Systems comprise mineral wool dual density (MWDD) or mineral wool lamella slabs, mechanically fixed, with supplementary adhesive (ensuring a minimum 40% coverage of adhesive), reinforced basecoat and either render or acrylic, or clay/ceramic brick slip, finishes.

1.2 For a 30-year durability, the systems are primarily fixed through the insulation slabs, with the reinforcing mesh immediately applied and embedded, and the surface smoothed with a trowel. For a 60-year durability application, additional mechanical fixings are applied through the insulation and basecoat while the basecoat is wet, before mesh patches are applied over the fixing heads and fully embedded. For both 30- and 60-year systems, a further layer of basecoat render is applied over the embedded reinforcing mesh to achieve the required overall thickness. When the basecoat is dry, the selected finishes are applied. See Figure 1, Table 1, and section 16.

Table 1 System options

Components	Option 1	Option 2
Adhesive	Klebocem/Klebocem Minerale	Klebocem Grosso
Insulation	Mineral wool lamella/MWDD	Mineral wool lamella/MWDD
Basecoat	Klebocem/Klebocem Minerale	Klebocem Grosso
Reinforcement	Armatex C1	Armatex A1 Armatex C1 Armatex C1 (reinforced)Termok8 lath profile mesh <sup>(1)</sup>
Primer	—	Acrylic brick-slip primer
Finish/top coat	Termok8 Rivatone Plus G12/G15 Termok8 Rivatone Idrosiliconico Plus G12/G15	Acrylic brick slip adhesive GlueFlex Ultra bedding mortar
Decorative profile	—	Aliva Lightweight Brick Slips Clay/ceramic brick slips <sup>(2)</sup> and SIGILTOW FL 30 grouting mortar

(1) Used as an optional secondary mesh only with clay/ceramic brick slips

(2) Systems incorporating clay/ceramic brick slip finishes can attain only 30-year durability.

### 1.3 The systems comprise:

#### Insulation<sup>(1)</sup>

- mineral wool dual density (MWDD) insulation slabs — 1200 by 600 mm slabs in a range of thicknesses from 60<sup>(1)</sup> to 250 mm with a nominal density of 160/110 kg·m<sup>-3</sup> (outer/inner layer), compressive strength of 20 kN·m<sup>-2</sup> and tensile strength perpendicular to the faces of 10 kPa. The slabs comply with the requirements of BS EN 13162 : 2012
- mineral wool lamella — mineral fibre slabs, in sizes up to 1200 by 200 mm and in thicknesses from 60 to 250 mm, with a nominal density of 85 kg·m<sup>-3</sup>, minimum compressive strength of 40 kN·m<sup>-2</sup> and tensile strength perpendicular to the faces of 80 kN·m<sup>-2</sup>. The slabs comply with the requirements of BS EN 13162 : 2012

(1) For declared thermal conductivity values ( $\lambda_D$ ), see Table 3.

(2) Insulation thicknesses of 20 to 60 mm are available, and would generally be used in reveals.

#### Mechanical fixings

- TermoK8 fixings<sup>(1)(2)</sup> — a range of anchor plugs, with an anchorage depth of at least 25 mm, approved and supplied by the Certificate holder selected from:
  - Ejot EjoTherm NT U — a polyethylene anchor sleeve, with stainless steel or galvanized steel pin
  - Ejot EjoTherm STR U — a polyethylene anchor sleeve, with stainless steel or galvanized steel screw
  - Ejot EjoTherm SDK U — a polyethylene anchor sleeve, with stainless steel or galvanized steel screw
  - Ejot H1 Eco — a polyethylene anchor sleeve, with galvanized steel pin

(1) Other fixings may be used provided they can be demonstrated to have equal or higher pull out, plate diameter, plate stiffness and material characteristics.

(2) Must have a stainless steel pin/screw to achieve 60-year durability performance.

#### Adhesive (supplementary)

- Klebocem/Klebocem Minerale and Klebocem Grosso — grey or white cementitious powders with a particle size of 0.6 mm (Klebocem/Klebocem Minerale) or 1.2 mm (Klebocem Grosso). The products are mixed with 5 litres of clean water per 25 kg bag to form a paste and applied at a coverage of 9 kg·m<sup>-2</sup>, to give a finished thickness of 5 to 7 mm. Used to fix the insulation slabs to the substrate

#### Basecoat

- Klebocem/Klebocem Minerale — grey or white cementitious powders with particle size of 0.6 mm, mixed with approximately 24% water by volume to form a paste with a coverage rate of approximately 2.5 to 3.5 kg·m<sup>-2</sup> to give a minimum thickness of 6 mm
- Klebocem Grosso — grey or white cementitious powders with a particle size of 1.2 mm, mixed with approximately 5 litres of clean water per 25 kg bag to form a paste and applied to a minimum thickness of 6 mm

#### Reinforcement

- Armatex A1 — a woven alkali-resistant glass fibre reinforcing mesh, grid size approximately 3 by 3.5 mm, with a polymer coating and nominal weight of 160 g·m<sup>-2</sup>
- Armatex C1 — a woven alkali-resistant glass fibre reinforcing mesh, grid size approximately 3 by 3.5 mm, with a polymer coating and nominal weight of 160 g·m<sup>-2</sup>
- Armatex C1 (reinforced) — a woven alkali-resistant glass fibre reinforcing mesh, grid size approximately 4 by 3.8 mm, with a polymer coating and nominal weight of 370 g·m<sup>-2</sup>
- TermoK8 lath profile mesh — a stainless steel reinforcing mesh profile, sized 2440 by 685 mm, with grid size approximately 9 by 9 mm, and a nominal weight of 1.15 k·m<sup>-2</sup>. This is an optional mesh only to be used with clay/ceramic brick slips.

#### Primer

- Acrylic brick-slip primer — a water-based single-component primer, supplied in liquid form, for use with acrylic render or Aliva Lightweight Brick Slips.

### Top coat

- acrylic brick-slip adhesive — a ready to use polymer dispersion adhesive paste and joint mortar. Supplied pre-coloured in white, light grey and brown, and applied at a coverage of  $3.4 \text{ kg}\cdot\text{m}^{-2}$  to give a minimum 2 mm thickness
- GlueFlex Ultra bedding mortar — a cementitious adhesive mortar conforming to BS EN 12004 : 2007, comprising cement conforming to BS EN 197-1 : 2011 and additives. Mixed with approximately 6.5 to 7 litres of clean water per 25 kg bag to form a paste with a coverage rate of approximately  $2.5$  to  $3.5 \text{ kg}\cdot\text{m}^{-2}$ , to give a 3 to 5 mm thickness. Used for the application of the clay/ceramic brick slips

### Finishes

- TermoK8 Rivatone Plus G12/G15 — an acrylic resin-based ready-to-use granular paste, with 1.2 and 1.5 mm particle sizes. Thickness is regulated by particle sizes, but it can be applied to a maximum thickness of 3 mm, with a coverage rate of approximately of  $2.5$  to  $3.5 \text{ kg}\cdot\text{m}^{-2}$ . Available in a range of colours
- TermoK8 Rivatone Idrosiliconico Plus G12/G15 — silicone resin-based ready-to-use granular pastes, with 1.2 and 1.5 mm particle sizes. Thickness is regulated by particle sizes, but it can be applied to a maximum thickness of 3 mm, with a coverage rate of approximately of  $2.5$  to  $3.5 \text{ kg}\cdot\text{m}^{-2}$ . Available in a range of colours

### Brick slips

- Aliva Lightweight Brick Slips — 4 to 6 mm thick, 65 mm wide by 215 mm long, weather-resistant pre-coloured, acrylic brick slips with an equivalent water vapour diffusion value ( $S_d$ ) of less than or equal to 1.36 (see sections 11.1 and 11.2)
- Clay/ceramic brick slips — extruded or cut brick slips in the following sizes: 6 to 14 mm thick, 65 mm wide by 215 mm long, and 8 to 20 mm thick, 55 mm wide by 250 mm long. Complies with BS EN 771-1 : 2011, with an equivalent water vapour diffusion value ( $S_d$ ) of less than or equal to 1.79 (see sections 11.1 and 11.2)

### Grouting mortar

- SIGILTOW FL 30 grouting mortar — a grey-coloured cement powder mortar for sealing joints between tiles, from 3 to 15 mm, with a classification as per EN 13888 : 2009. CG2 comprising a mixture of cement, fine aggregates, resins, additives and pigments, with compressive strength of  $30 \text{ N}\cdot\text{mm}^{-2}$ , to a coverage of  $1.10 \text{ kg}\cdot\text{m}^{-2}$ .

Figure 1 TermoK8 Minerale External Wall Insulating Render Systems

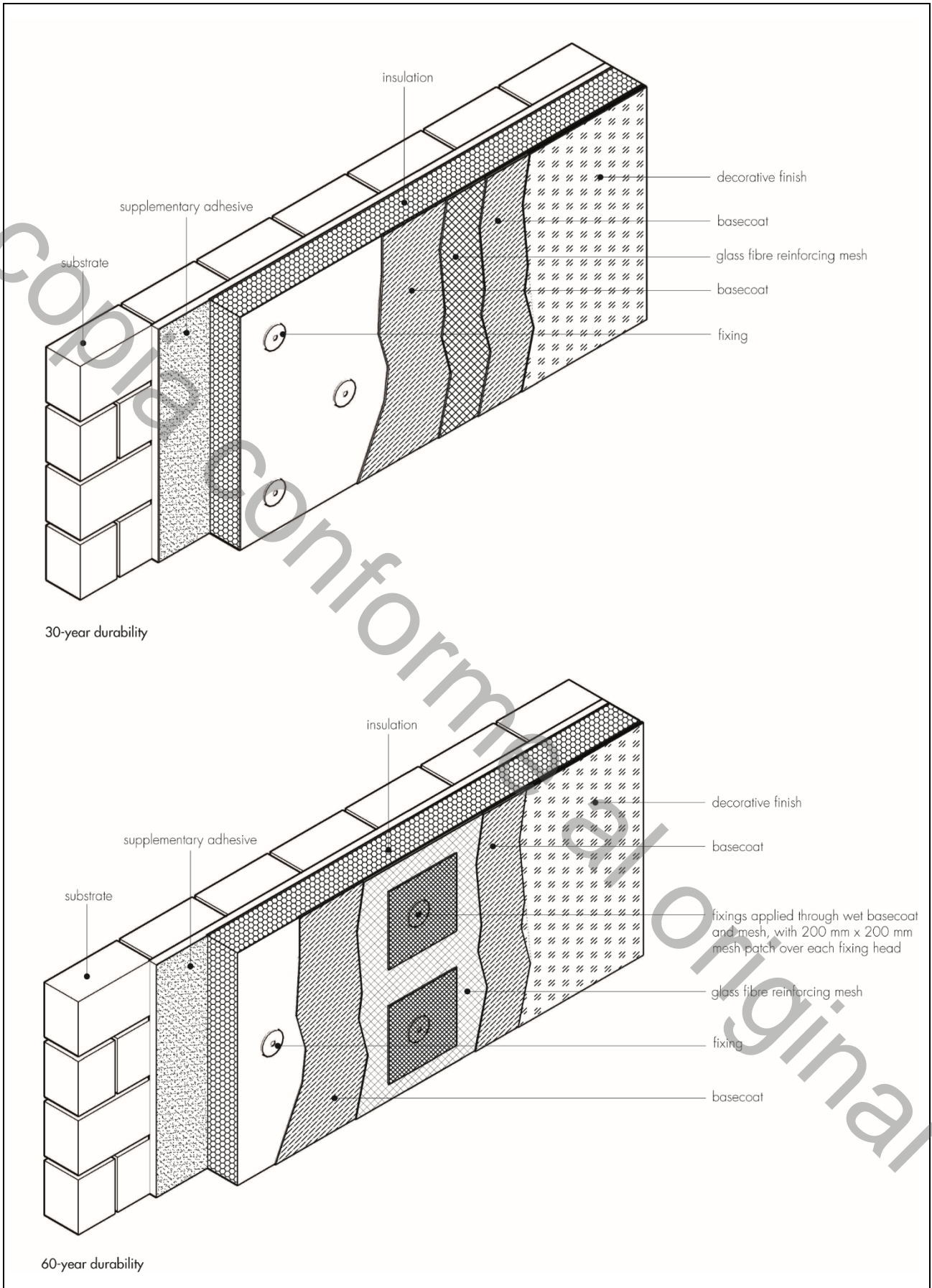

1.4 Ancillary materials also used with the systems include a range of aluminium, PVC-U or stainless steel profiles, comprising:

- base profile
- edge profile
- corner profile
- render stop profile
- movement joint (expansion joint)
- connectors
- Ejotherm SDK U and NK U profile fixings.

1.5 Ancillary materials also used with the systems but outside the scope of this Certificate include:

- fungicidal wash
- water-based masonry cleaner
- steriliser containing biocides
- expansion foam
- sealants — silicone or mastic silicone in accordance with BS EN ISO 11600 : 2003
- cement or polymer-based mortar to repair the substrate surface.

## 2 Manufacture

2.1 The systems' components are manufactured by the Certificate holder or bought in from suppliers, to an agreed specification.

2.2 As part of the assessment and ongoing surveillance of product quality, the BBA has:

- agreed with the manufacturer the quality control procedures and product testing to be undertaken
- assessed and agreed the quality control operated over batches of incoming materials
- monitored the production process and verified that it is in accordance with the documented process
- evaluated the process for management of nonconformities
- checked that equipment has been properly tested and calibrated
- undertaken to carry out the above measures on a regular basis through a surveillance process, to verify that the specifications and quality control operated by the manufacturer are being maintained.

2.3 The systems are marketed in the UK by Aliva UK, 1210 Parkview, Arlington Business Park, Theale, Berkshire RG7 4TY, Tel: 01189 635 900, e-mail: enquiries@gruppovoivas.co.uk

## 3 Delivery and site handling

3.1 The insulation is delivered wrapped in polythene. The other components are delivered to site in the quantities and packaging listed in Table 2. Each package carries the product identification and manufacturer's batch number.

Table 2 Components – supply details<sup>(1)</sup>

Component	Quantity
Klebocem or Klebocem Minerale and Grosso adhesives	25 kg bags
Klebocem or Klebocem Minerale and Grosso basecoats	25 kg bags
Armatex A1, C1 and Armatex C1 (reinforced) reinforcing meshes	50 by 1 m rolls
TermoK8 lath profile reinforcing mesh	2440 by 685 mm sheet
TermoK8 Rivatone Plus G12/G15	25 kg plastic tubs
TermoK8 Rivatone Idrosiliconico Plus G12/G15	25 kg plastic tubs
Acrylic brick slip adhesive	20 kg bucket
GlueFlex Ultra bedding mortar	25 kg bags
Acrylic brick slip primer	15 kg tubs
Aliva Lightweight Acrylic Brick Slips	200 per box
Clay/ceramic brick slips	60 per box
SIGILTOW FL 30 grouting mortar	5 kg bags
Mechanical fixings	Boxed by manufacturer

(1) Ancillary items, such as aluminium profiles or fixings, are supplied boxed as appropriate.

3.2 The insulation should be stored on a firm, clean, level base, off the ground and under cover until required for use. Care must be taken when handling the insulation to avoid damage.

3.3 The powder components must be stored in a safe area, in dry conditions, off the ground and protected from moisture. Contaminated materials should be discarded.

3.4 The paste finishes should be stored in a safe area, under cover, and protected from excessive heat and frost at all times.

## Assessment and Technical Investigations

The following is a summary of the assessment and technical investigations carried out on TermoK8 Minerale External Wall Insulating Render Systems.

## Design Considerations

### 4 General

4.1 TermoK8 Minerale External Wall Insulating Render Systems, when installed in accordance with this Certificate, are satisfactory for use in reducing the thermal transmittance (U value) of external masonry or concrete walls of new and existing buildings. It is essential that the detailing techniques specified in this Certificate are carried out to a high standard if the ingress of water into the insulation is to be avoided and the full thermal benefit obtained from treatment with the system (eg the insulation must be protected by an overhang, and window sills should be designed and installed so as to direct water away from the building – see Figure 11).

4.2 For improved thermal/carbon-emissions performance, the designer should consider additional/alternative fabric and/or services measures.

4.3 The systems are for application to the outside of external walls of masonry normal weight concrete, lightweight concrete, autoclaved concrete and no-fines concrete construction, on new or existing domestic and non-domestic buildings (with or without existing render). Prior to the installation of the systems, wall surfaces should comply with section 14 of this Certificate.

4.4 New walls subject to national Building Regulations should be constructed in accordance with the relevant recommendations of:

- BS EN 1992-1-1 : 2004 and its UK National Annex
- BS EN 1996-1-1 : 2005 and its UK National Annex
- BS EN 1996-2 : 2006 and its UK National Annex
- BS 8000-0 : 2014
- BS 8000-2.2 : 1990

- BS 8000-3 : 2001.

4.5 New walls not subject to regulatory requirements should also be built in accordance with the Standards identified in section 4.4.

4.6 Movement joints should be incorporated into the systems in line with existing movement joints in the building structure in accordance with the Certificate holder's recommendations for the specific installation.

4.7 The systems will improve the weather resistance of a wall and provide a decorative finish. However, for existing buildings, they should only be installed where there are no signs of dampness on the inner surface of the wall other than those caused solely by condensation.

4.8 The effect of the systems on the acoustic performance of a construction is outside the scope of this Certificate.

4.9 The fixing of sanitary pipework, plumbing, rainwater goods, satellite dishes, clothes lines, hanging baskets and similar items to the systems is outside the scope of this Certificate.

4.10 External pipework and ducts should be removed before installation, and alterations made to underground drainage to accommodate repositioning of the pipework to the finished face of the systems. The Certificate holder may advise on suitable fixing methods, but these are outside the scope of this Certificate.

4.11 The designer should select a construction appropriate to the local wind-driven rain index, paying due regard to the design detailing, workmanship and materials to be used.

4.12 It is essential that the systems are installed and maintained in accordance with the conditions set out in this Certificate.

4.13 The systems can be adapted to achieve an extended service life of 60 years instead of the standard 30, except for systems incorporating clay/ceramic brick slip finishes. The difference between 30- and 60-year durability systems is covered in sections 1.1 to 1.3, with the detailed installation procedure covered in section 16.

4.14 For 60-year durability systems, the following components must be constructed from stainless steel grade 1.4301 to BS EN 10088-2 : 2014:

- base profile and render stop end including the fixings. In addition, any other profile component which would remain exposed after the application of the finish coat
- corner profile (if exposed after application of the systems)
- pin or screw for mechanical fixings.

## 5 Practicability of installation

The systems should only be installed by specialist contractors who have successfully undergone training and registration by the Certificate holder (see section 15).

Note: The BBA operates a UKAS-accredited Approved Installer Scheme for external wall insulation; details of approved installer companies are included on the BBA's website ([www.bbacerts.co.uk](http://www.bbacerts.co.uk)).

## 6 Thermal performance



6.1 Calculations of thermal transmittance (U value) should be carried out in accordance with BS EN ISO 6946 : 2017 and BRE Report BR 443 : 2006, using the declared thermal conductivity values ( $\lambda_D$ ) of the insulations given in Table 3.

Table 3 Declared thermal conductivity values ( $I_D$ ) and available thicknesses

Insulation type	Thickness (mm)	Thermal conductivity ( $W \cdot m^{-1} \cdot K^{-1}$ )
Mineral wool dual density (MWDD)	60 to 250	0.036
Mineral wool lamella	60 to 250	0.042



6.2 The U value of a completed wall will depend on the insulation type and thickness, the type and number of fixings, and the insulating value of the substrate masonry and its internal finish. Calculated U values for sample constructions in accordance with the national Building Regulations are given in Table 4, and are based on the thermal conductivities given in Table 3.

Table 4 Insulation thickness required to achieve design U values<sup>(1)(2)(3)</sup>

U value ( $W \cdot m^{-2} \cdot K^{-1}$ ) <sup>(4)</sup>	Thickness of insulation <sup>(3)</sup> (mm)			
	215 mm brickwork, $\lambda = 0.56 W \cdot m^{-1} \cdot K^{-1}$		200 mm dense blockwork, $\lambda = 1.75 W \cdot m^{-1} \cdot K^{-1}$	
	MWDD	Lamella	MWDD	Lamella
0.18	190	220	200	230
0.19	180	210	190	220
0.25	130	150	140	160
0.26	130	150	130	160
0.28	120	130	120	140
0.30	110	120	110	130
0.35	90	100	100	110

(1) Wall construction inclusive of 13 mm plaster ( $\lambda = 0.57 W \cdot m^{-1} \cdot K^{-1}$ ), brickwork (protected) with 17.1% mortar or dense blockwork with 6.7% mortar ( $\lambda = 0.88 W \cdot m^{-1} \cdot K^{-1}$ ). A 5 mm thick adhesive layer with  $\lambda = 1 W \cdot m^{-1} \cdot K^{-1}$  covering 40% of the area is also included, and a slab emissivity of 0.9, together with an external render thickness of 7.2 mm with  $\lambda = 1 W \cdot m^{-1} \cdot K^{-1}$ .

(2) Calculations based on system that included 7.2 stainless steel fixings per square metre with a point thermal transmittance ( $X_p$ ) of  $0.002 W \cdot m^{-1} \cdot K^{-1}$  per steel pin. Use of other types of fixings should be calculated in accordance with BS EN ISO 6946 : 2017. A gap correction ( $DU$ ) of zero is assumed.

(3) Based upon incremental insulation thickness of 10 mm.

(4) When applying the maximum available insulation thickness, these walls can achieve U values from 0.14 to  $0.17 W \cdot m^{-2} \cdot K^{-1}$  depending on insulation type and wall type.

6.3 Care must be taken in the overall design and construction of junctions with other elements and openings to minimise thermal bridges and air infiltration. Detailed guidance can be found in the documents supporting the national Building Regulations.

## 7 Strength and stability

### General



7.1 The Certificate holder is ultimately responsible for the design of the systems and it is the responsibility of the company installing the systems to accurately follow the installation instructions (see also section 5 of this Certificate). The Certificate holder must also verify that a suitably experienced and qualified individual (with adequate professional indemnity) establishes that:

- the wind loads on the different zones of the building's elevation for the specific geographical location have been calculated correctly (see section 7.3)
- the systems can adequately resist and safely transfer the calculated loads, accounting for all possible failure modes, to the substrate wall and supporting structure (see sections 7.3 to 7.6).

7.2 The substrate and supporting structure must be capable of transferring all additional loading due to the installation of the systems to the ground in a satisfactory manner. The adequacy of the substrate and supporting structure must be verified by the person or party responsible for the global stability of the building to which the system is applied. Any defects should be made good prior to the system being installed.

7.3 The wind loads on the walls should be calculated, taking into account all relevant factors such as location and topography, in accordance with BS EN 1991-1-4 : 2005 and its UK National Annex. All of the factors affecting wind load on each elevation and specific zones of the building must be considered. In accordance with BS EN 1990 : 2002 and its UK National Annex, a partial factor of 1.5 must be applied to the calculated characteristic wind pressure values to establish the design wind load to be resisted by the systems.

7.4 Installations correctly designed in accordance with this Certificate will safely accommodate the applied loads due to the self-weight of the system, wind and impact.

7.5 Positive wind load is transferred to the substrate wall directly via compression through the render and insulation systems.

7.6 Negative wind load is transferred to the substrate wall via<sup>(1)(2)</sup>:

- the bond between the insulation and render system (see section 7.7)
- the pull-out resistance of the fixing from the substrate wall (see section 7.8)
- the pull-through resistance of the fixing (see section 7.9).

(1) For mechanically fixed systems with supplementary adhesive, the contribution of the adhesive is not considered when calculating resistance to wind load.

(2) Further guidance is available from BBA Guidance Note 1, available on the BBA website ([www.bbacerts.co.uk](http://www.bbacerts.co.uk)).

7.7 The characteristic bond resistance between the insulation and basecoat render was determined from tests as  $10 \text{ kN}\cdot\text{m}^{-2}$  for mineral wool dual density (MWDD), and  $80 \text{ kN}\cdot\text{m}^{-2}$  for mineral wool lamella. The design resistance of the bond between the insulation and render ( $N_{RD1}$ ) should be taken as the characteristic bond resistance divided by a partial factor of 9.

7.8 Typical characteristic pull-out resistances for the fixings taken from the corresponding European Technical Assessment (ETA) are given in Table 5; the values are dependent on the fixing type and must be selected to suit the specific loads and substrate concerned. In situations where suitable data does not exist<sup>(1)</sup>, the characteristic pull-out resistance must be established from site-specific pull-out tests conducted on the substrate of the building to ascertain the minimum resistance to pull-out failure of the fixings, and determined in accordance with the guidance given in EOTA TR051 (minimum test characteristic value =  $0.6 \times$  mean of 5 lowest test results). To obtain the design pull-out resistance of the fixings ( $N_{RD2}$ ), this characteristic pull-out resistance should then be divided by the partial safety factor given in Table 5.

(1) To qualify as suitable data, the age and condition of the substrate must be equivalent to that used to establish the values in the ETA

Table 5 Fixings — typical characteristic pull-out resistances

Fixing Type <sup>(1)</sup>	ETA number	Substrate	Drill diameter (mm)	Effective anchorage depth (mm)	Typical pull out strength (kN) <sup>(2)</sup>	Partial safety factor
Ejotherm NT U	05/0009	Concrete C16/20 Brickwork	8	25	1.2 1.5	2
Ejotherm STR U Ejotherm SDK U	04/0023	Concrete C12/15 Brickwork	8	25	1.5	2
Ejot H1 Eco	11/0192	Concrete C12/15 Brickwork	8	25	0.9	2

(1) The minimum values for plate stiffness of fixings is  $0.6 \text{ kN}\cdot\text{mm}^{-2}$  and the load resistance is 1.4 kN.

(2) Values are determined in accordance with EAD 330196-00-0604 : 2016 and are dependent on the substrate. The Use Categories are defined in the corresponding ETA.

7.9 The characteristic pull-through resistance of the fixings was determined from tests using a 60 mm diameter fixing plate and minimum insulation thickness of 60 or 100 mm, depending on the mechanical fixings used. The design resistance per fixing ( $N_{RD3}$ ) is obtained by applying an appropriate partial factor as shown in Table 6.

**Table 6 Design pull-through resistances**

Factor (unit) Fixing type <sup>(1)</sup>	Pull through data			
	MWDD			MW lamella
	Ejot NTU	Ejot H1 eco	Ejot NTU	Ejot NTU
Tensile resistance of the insulation (kN.m <sup>-2</sup> )	10	10		80
Fixing plate diameter (mm)			60	
Insulation thickness (mm)	60	100		60
Characteristic pull through resistance <sup>(2)</sup> per fixing at panel (kN)	0.36	0.47	0.54	0.51
Partial factor <sup>(3)</sup>			2.5	
Design pull through resistance per fixing at panel (N <sub>rd3</sub> ) (kN)	0.14	0.19	0.22	0.20
Design pull through resistance per slab (kN) (based on the minimum number of fixings) <sup>(4)</sup>	0.70	0.95	1.10	1.02
Design pull through resistance per slab (kN) (based on maximum number of fixings) <sup>(5)</sup>	1.3	1.71	1.98	1.8

(1) See Table 5 for typical characteristic pull-out resistance of the fixings.

(2) Characteristic pull-through resistance of insulation over the head of the fixing, in accordance with BS EN 1990 : 2002, Annex D7.2 and its UK National Annex.

(3) The partial factor is based on the assumption that all insulation slabs are quality controlled and tested to establish tensile strength perpendicular to the face of the slab.

(4) The minimum design pull through resistance per slab is based on a minimum of 5 fixings per slab (1200 x 600 mm, MWDD) (0.72 m<sup>2</sup>), which equates to approximately 7 fixings per m<sup>2</sup>.

(5) The maximum design pull through resistance per slab is based on a maximum of 9 fixings per slab (1200 x 600 mm, MWDD) (0.72 m<sup>2</sup>), which equates to approximately 12.5 fixings per m<sup>2</sup>. The design resistance for the maximum number of fixings is only applicable to the minimum insulation thickness tested and as specified in Table 4. The fixing pattern, insulation thickness and interaction of the fixings should be considered when calculating the design resistance per slab.

7.10 The number and spacing of the fixings should be determined by the Certificate holder. The number of fixings must not be less than the minimum specified for the systems and the fixings should be symmetrically positioned about the centre of the slab both in vertical and horizontal directions except at openings and building corners.

7.11 The data derived from sections 7.7 to 7.9 must be assessed against the design wind load and the following expression must be satisfied:

For safe design:

$$R_d \geq W_e$$

$$R_{d,b,ins/rend} = A_r * N_{RD1}$$

$$R_{d,pull-out} = n * N_{RD2}$$

$$R_{d,pull-through} = (N_{RD3panel} * n_{panel}) + (N_{RD3joint} * n_{joint})$$

Where:

**R<sub>d</sub>** is the design ultimate resistance (N·m<sup>-2</sup>) taken as the minimum of **R<sub>d,b,ins/rend</sub>**, **R<sub>d,pull-out</sub>** and **R<sub>d,pull-through</sub>**

**W<sub>e</sub>** is the maximum design wind load (N·m<sup>-2</sup>)

**R<sub>d,b,ins/rend</sub>** is the design bond resistance between the insulation and render (N·m<sup>-2</sup>)

**R<sub>d,pull-out</sub>** is the design pull-out resistance of the insulation fixings per metre square (N·m<sup>-2</sup>)

**R<sub>d,pull-through</sub>** is the design pull-through resistance of the insulation fixings per metre square (N·m<sup>-2</sup>)

**A<sub>r</sub>** is the reinforced basecoat bond area (based on % area covered)

**N<sub>RD1</sub>** is the design adhesive bond resistance between the insulation and render, based on test (N·m<sup>-2</sup>)

**n** is number of anchor fixings per m<sup>2</sup>

**N<sub>RD2</sub>** is the design pull out resistance per fixing based on test (N) per fixing

**N<sub>RD3panel</sub>** is the design pull-through resistance per anchor not placed at the panel joint, based on test (N)

**N<sub>RD3joint</sub>** is the design pull-through resistance per anchor placed at the panel joint, based on test (N)

**n<sub>panel</sub>** is number of internal anchors in a panel

$n_{\text{joint}}$  is number of internal joint anchors in a panel  
 $A_{\text{slab}}$  is the area of the slab ( $\text{m}^2$ ).

7.12 The insulation systems are mechanically fixed to the substrate wall with a minimum of 5 fixings per slab (MWDD) or approximately 7 fixings per square metre, as per the fixing patterns shown in Figure 5, and in conjunction with a minimum 40% coverage of supplementary adhesive (see section 16 of this Certificate). Additional fixings may be required, depending on the results of the calculations detailed above for the specific site.

### Impact resistance

7.13 Hard body impact tests were carried out in accordance with ETAG 004 : 2013. The systems are suitable for the Use Categories up to and including those specified in Table 7 of this Certificate.

Table 7 Impact resistance

Rendering system: Basecoat and finishing coats, as indicated below	Category <sup>(1)</sup>		
	Single glass fibre mesh (standard)	Double glass fibre mesh (reinforced mesh)	TermoK8 lath profile
Klebocem/Klebocem Minerale + TermoK8 Rivatone Plus G12/G15	II	I	–
Klebocem/Klebocem Minerale + TermoK8 Rivatone Idrosiliconico Plus G12/15	II	I	–
Klebocem Grosso + Acrylic Brick Slip Adhesive + Aliva Lightweight Brick Slips	II	–	–
Klebocem Grosso + GlueFlex Ultra Bedding Mortar + Clay/Ceramic Brick Slips	–	–	I

(1) The Use Categories are defined in ETAG 004 : 2013 as:

- Category I — a zone readily accessible at ground level to the public and vulnerable to hard body impacts but not subjected to abnormally rough use
- Category II — a zone liable to impacts from thrown or kicked objects, but in public locations where the height of the systems will limit the size of the impact; or at lower levels where access to the building is primarily to those with some incentive to exercise care
- Category III — a zone not likely to be damaged by normal impacts caused by people or by thrown or kicked objects.

## 8 Behaviour in relation to fire



8.1 The reaction to fire classifications<sup>(1)</sup> of the systems are detailed in Table 8, below:

(1) Copies of the reports are available from the Certificate holder on request.

Table 8 Fire classification

System Options: Insulation, basecoat, mesh, and finishing coats, as listed below:	Fire Classification
MW/Lamella + Klebocem/Klebocem Minerale + Armatex C1 + Termok8 Rivatone Plus G12/G15	A2-s1, d0
MW/Lamella + Klebocem/Klebocem Minerale + Armatex C1 + Termok8 Rivatone Idrosiliconico Plus G12/15	
MW/Lamella + Klebocem Grosso + Armatex C1 or Armatex C1 (reinforced) + Acrylic Brick Slip Adhesive + Aliva Lightweight Brick Slips	
MW/Lamella + Klebocem Grosso + Armatex C1 or Armatex C1 (reinforced) + GlueFlex Ultra bedding mortar + Clay/Ceramic Brick Slips and SIGILTOW FL 30 Grouting Mortar	A1
MW/Lamella + Klebocem Grosso + Armatex A1 + GlueFlex Ultra bedding mortar + Clay/Ceramic Brick Slips and SIGILTOW FL 30 Grouting Mortar	

- Istituto Giordano, classification report No. 369266 to UNI EN 13501-1 : 2019
- Istituto Giordano, classification report No. 369259 to UNI EN 13501-1 : 2019
- Afiti Licof, classification report No. 1909T09-2 to UNE EN 13501-1 : 2007
- Exova, fire test report 393080 to BS EN 13501-1 : 2018.
- Istituto Giordano, classification report No. 378528 to UNI EN 13501-1 : 2019
- Istituto Giordano, classification report No. 383046 to UNI EN 13501-1 : 2019
- Istituto Giordano, classification report No 387451 to UNI EN 13501-1 : 2019



8.2 For the acrylic brick slip system, this classification applies only where the calorific value of the specific brick slip used is no greater than 2.6 MJ·kg. The Certificate holder should be consulted to confirm the calorific value of a particular acrylic brick slip.

8.3 For the clay brick slips, this classification applies only to brick slips with a classification of A1 to BS EN 13501-1 : 2018.

8.4 The fire classifications apply to the full range of thicknesses and colours covered by this Certificate.

8.5 The Mineral Wool DD and Lamella insulation materials in isolation have an A1 fire classification in accordance with BS EN 13501-1 : 2018.

8.6 The systems defined in sections 8.1 to 8.3 are suitable for use in buildings without height restriction on, or at any distance from, the boundary.

8.7 The classification and permissible areas of use of the system for brick slips not satisfying the specifications defined in sections 8.1 to 8.3 should be confirmed by reference to the documents supporting the national Building Regulations.

8.8 For application to second storey walls and above, it is recommended that the designer considers at least one stainless steel fixing per square metre as advised in BRE Report BR 135 : 2013.

8.9 NHBC Standards require in all cases that a minimum of one non-combustible fixing through the reinforcement mesh, per square metre or per insulation slab, whichever provides the greater number, should be provided, in addition to the other fixings.

8.10 Designers should refer to the relevant national Building Regulations and guidance for detailed conditions of use, particularly in respect of requirements for substrate fire performance, cavity barriers, service penetrations and combustibility limitations for other materials and components used in the overall wall construction.

## 9 Proximity of flues and appliances

Detailed guidance can be found in the documents supporting the national Building Regulations for the provisions that are applicable when the system is installed in close proximity to certain flue pipes and/or heat-producing appliances.

## 10 Water resistance



10.1 The systems will provide a degree of protection against water ingress. However, care should be taken to ensure that walls are adequately watertight prior to application of the systems. The systems must only be installed where there is no sign of dampness on the inner surface of the substrate other than that caused solely by condensation.

10.2 Designers and installers should take particular care in detailing around openings, penetrations and movement joints to minimise the risk of water ingress.

10.3 The guidance given in BRE Report BR 262 : 2002 should be followed in connection with the watertightness of solid wall constructions. The designer should select a construction appropriate to the local wind-driven rain index, paying due regard to the design detailing, workmanship and materials to be used.

10.4 At the top of walls, the systems should be protected by an adequate overhang or other detail designed for use with these types of systems (see section 16).

## 11 Condensation

11.1 Designers must ensure that an appropriate condensation risk analysis has been carried out for all parts of the construction, including openings and penetrations at junctions between the insulation system and windows, to minimise the risk of condensation. The recommendations of BS 5250 : 2011 should be followed.



11.2 For brick slip systems, the water vapour permeability of the specific brick slip used must be included in the above analysis and this should be a maximum equivalent water vapour diffusion value ( $S_d$ ) of 1.36 for the acrylic brick slips system and 1.79 for the clay/ceramic brick slips system. The appropriate figure for the brick slip chosen for a particular installation should be obtained from the Certificate holder in each case.

### Surface condensation



11.3 Walls will adequately limit the risk of surface condensation when the thermal transmittance (U value) does not exceed  $0.7 \text{ W}\cdot\text{m}^{-2}\cdot\text{K}^{-1}$  at any point and the junctions with other elements and openings comply with section 6.3 of this Certificate.



11.4 Walls will adequately limit the risk of surface condensation when the thermal transmittance (U value) does not exceed  $1.2 \text{ W}\cdot\text{m}^{-2}\cdot\text{K}^{-1}$  at any point. Guidance may be obtained from BS 5250 : 2011 Section 4 and Annex G, and BRE Report BR 262 : 2002.

### Interstitial condensation



11.5 Walls incorporating the systems will adequately limit the risk of interstitial condensation when they are designed and constructed in accordance with BS 5250 : 2011, Section 4 and Annexes D and G.

11.6 The water vapour resistance factor ( $\mu$ ) and equivalent air layer thicknesses ( $S_d$ ) are shown in Table 9.

Table 9 Examples of water vapour resistance factor ( $\mu$ ) and equivalent air layer thickness ( $S_d$ )

Layers	Thickness (mm)	$S_d$ (m)	$\mu$
Mineral wool dual density (MWDD)	60 to 250	–	1 <sup>(2)</sup>
Mineral wool lamella	60 to 250	–	1
Rendering system: basecoat and finish coat, as indicated below			
Klebocem/Klebocem Minerale (4 mm) <sup>(1)</sup> + TermoK8 Rivatone Plus G12 (1.2 mm) <sup>(1)</sup>	5.2 to 9	0.04	–
Klebocem/Klebocem Minerale (4 mm) <sup>(1)</sup> + TermoK8 Rivatone Plus G15 (1.5 mm) <sup>(1)</sup>		0.02	
Klebocem/Klebocem Minerale (4 mm) <sup>(1)</sup> + TermoK8 Rivatone Idrosiliconico Plus G12 (1.2 mm) <sup>(1)</sup>	5.2 to 9		–
Klebocem/Klebocem Minerale (4 mm) <sup>(1)</sup> TermoK8 Rivatone Idrosiliconico Plus G15 (1.5 mm) <sup>(1)</sup>		0.05	
Klebocem Grosso + Acrylic Brick Slip Adhesive + Aliva Lightweight Brick Slips	14	1.36 <sup>(1)</sup>	–
Klebocem Grosso + GlueFlex Ultra Bedding Mortar + Clay/Ceramic Brick Slips	22.7	1.79 <sup>(1)</sup>	–

(1) The  $S_d$  (m) is only applied to the tested thickness; different thickness should be obtained by further testing.

(2) Figure in accordance with BS EN ISO 10456 : 2007.

11.7 In all cases, a site-specific condensation risk analysis should be carried out by a suitably competent and experienced individual to confirm the specific systems' suitability for a particular building type and location.

## 12 Maintenance and repair



12.1 An initial inspection should be made within 12 months and regularly thereafter to include:

- visual inspection of the render for signs of damage. Cracks in the render exceeding 0.2 mm must be repaired.
- examination of the sealant around openings and service entry points.
- visual inspection of architectural details designed to shed water, to confirm that they are performing properly.
- visual inspection to ensure that water is not leaking from external downpipes or gutters; such leakage could penetrate the rendering.
- necessary repairs effected immediately and the sealant joints at window and door frames replaced at regular intervals.
- maintenance schedules, which should include the replacement and resealing of joints (for example, between the insulation system and window and door frame).

12.2 Damaged areas must be repaired using the appropriate components and procedures detailed in the Certificate holder's installation instructions and in accordance with BS EN 13914-1 : 2016.

## 13 Durability



13.1 The systems will remain effective for at least 30 years provided any damage to the surface finish is repaired immediately and regular maintenance is undertaken, as described in section 12.

13.2 The systems' service life can be extended to 60 years, except for systems incorporating clay/ceramic brick slip finishes, provided the systems are fixed through the reinforcing mesh and a planned inspection and maintenance programme is introduced in accordance with section 12. An extended 60 years' service life requires the use of stainless steel base and corner profiles, stainless steel centre pin fixings [304 Grade (1.4301)] and plastic anchor sleeve materials such as polyamide (PA6 and PA6.6), polyethylene (PE) or polypropylene (PP) and the following of an appropriate repair and maintenance schedule (as covered by the Certificate holder's repair and maintenance manual). Any damage to the surface finish must be repaired within a time period agreed by the Certificate holder.

13.3 Any render containing cement may be subject to lime bloom. The occurrence of this may be reduced by avoiding application in adverse weather conditions. The effect is transient and is less noticeable on lighter colours.

13.4 The renders may become discoloured with time, the rate depending on the initial colour, the degree of exposure and atmospheric pollution, as well as the design and detailing of the wall. In common with traditional renders,

discoloration by algae and lichens may occur in wet areas. The appearance may be restored by a suitable power wash or, if required, by over coating.

13.5 To maintain a high quality aesthetic appearance, it may be necessary to periodically overcoat the render finishes using a suitable masonry coating (that is, one covered by a valid BBA Certificate for this purpose) compatible with the decorative or finish coats. Care should be taken not to adversely affect the water vapour transmission or fire characteristics of the systems. The advice of the Certificate holder should be sought as to the suitability of a particular product.

## Installation

### 14 Site survey and preliminary work

14.1 A pre-installation survey of the property must be carried out to determine suitability for treatment and the need for any necessary repairs to the building structure before application of the systems. A specification is prepared for each elevation of the building indicating:

- additional corner mesh and reinforcement, where required
- the position of beads
- detailing around windows, doors and at eaves
- damp-proof course (dpc) level (outside the scope of this Certificate)
- exact position of expansion joints, if required
- areas where flexible sealants must be used
- any alterations to external plumbing, if required.

14.2 The survey should include tests conducted on the walls of the building by the Certificate holder or their approved installers (see section 15) to determine the pull-out resistance of the mechanical fixing. An assessment and recommendation is made on the type and number of fixings required to withstand the building's expected wind loading based on calculations using the test data and pull-out resistance (see section 7).

14.3 Surfaces should be sound, clean and free from loose material. The flatness of surfaces must be checked; this may be achieved using a straight edge spanning the storey height. Any excessive irregularities, ie greater than 10 mm in one metre, must be made good prior to installation to ensure that the insulation slabs are installed with a smooth, in-plane finished surface.

14.4 Where surfaces are covered with an existing render, it is essential that the bond between the background and the render is adequate. All loose areas should be hacked off and reinstated.

14.5 On existing buildings, purpose-made window sills must be fitted to extend beyond the finished face of the systems. New buildings should incorporate suitably deep sills.

14.6 Internal wet work, eg screed or plastering, should be completed and allowed to dry prior to the application of the systems.

14.7 All modifications and necessary repairs to the building structure must be completed before installation commences.

### 15 Approved installers

Application of the systems, within the context of this Certificate, must be carried out by installers approved by the Certificate holder. A Certificate holder approved installer is a company:

- employing operatives who have been trained and approved by the Certificate holder to install the systems.
- which has undertaken to comply with the Certificate holder's application procedure, containing the requirement for each application team to include at least one member-operative trained by the Certificate holder.
- subject to at least one inspection per annum by the Certificate holder to ensure suitable site practices are being employed. This may include unannounced site inspections.

## 16 Procedure

### General

16.1 Installation of the systems should be carried out in accordance with the Certificate holder's installation instructions and this Certificate.

16.2 Weather conditions should be monitored to ensure correct application and curing conditions. Application of the mortar and finishes should not be carried out at temperatures below 5°C or above 35°C, or if exposure to frost is likely. The coating must be protected from rapid drying. Installation should not take place during rainfall or if rain is anticipated. In addition, cementitious-based renders must not be applied if the temperature will fall below 0°C within 72 hours of completion.

16.3 The planarity and condition of the substrate must be checked, and any protrusions exceeding 10 mm removed.

16.4 All rendering should be in accordance with the relevant recommendations of BS EN 13914-1 : 2016.

16.5 Where required, a fungicidal wash is applied to the entire surface of the external wall by brush, roller or spray.

16.6 The initial installation procedure is common to both systems (see section 1.1) and is described in sections 16.7 to 16.14 and 16.31 to 16.33.

### Positioning and securing insulation slabs

16.7 The base profile is secured to the external wall above the dpc using the approved profile fixings at approximately 300 mm centres (see Figure 2). Base profile connectors are inserted at all rail joints. Extension profiles are fixed to the front lip of the base profile or stop end channel where appropriate. Note: For a 60-year durability application, the base profile needs to be constructed using stainless steel material.

Figure 2 Typical section of base profile

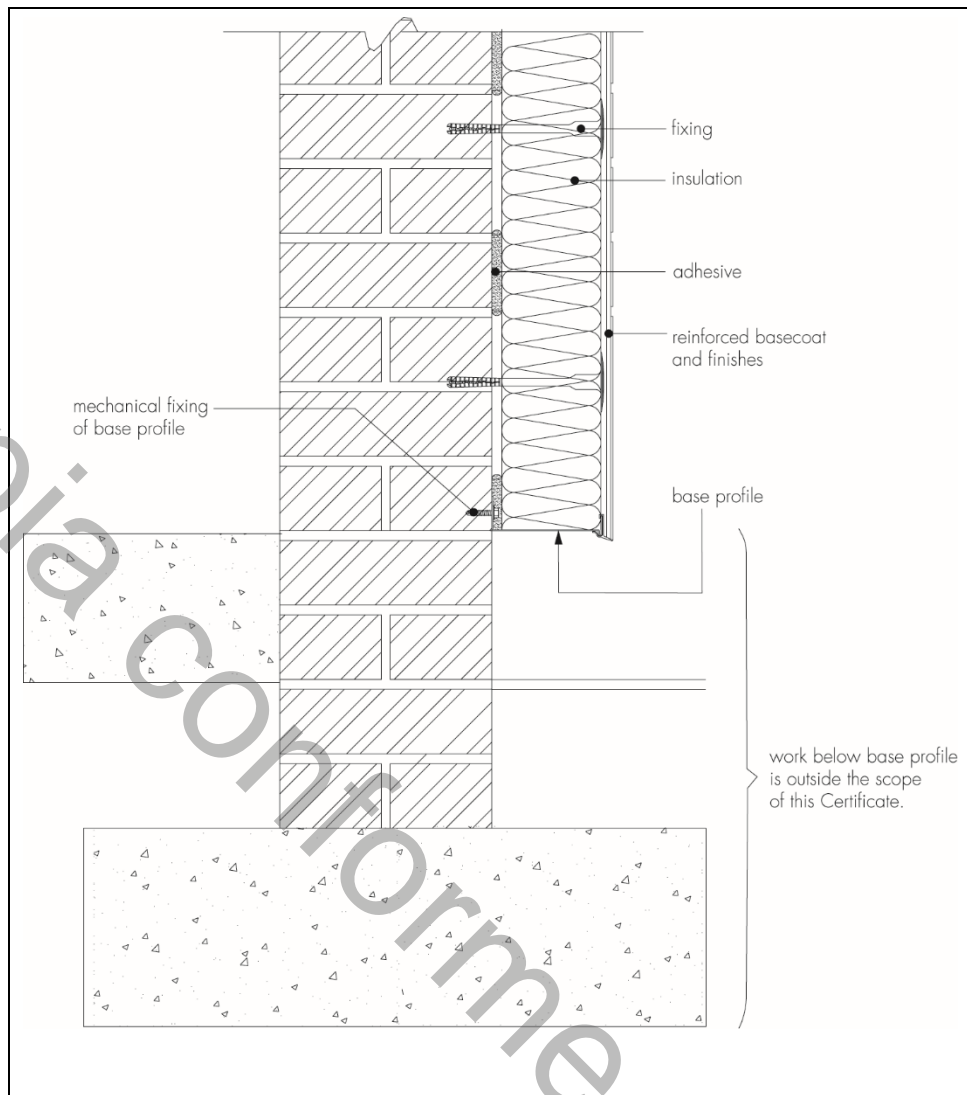

16.8 The supplementary adhesive is prepared with the required amount of water (see section 1.3), and mixed with a paddle mixer until the desired consistency is achieved. After allowing the adhesive to rest for 5 minutes, it is applied in a continuous bordering strip around the perimeter of the slab, with three additional dabs of approximate width between 10 and 40 mm distributed uniformly over the remaining surface, to achieve an overall minimum 40% coverage. Alternatively, a serrated edge trowel with 5 mm serrations can be used to apply the adhesive to the entire rear surface of the insulation slab.

16.9 The first run of insulation slabs, with the adhesive applied, is positioned on the base profile. The slabs must be pressed firmly against the wall, butted tightly together and aligned to achieve a level finish. Subsequent rows of slabs are positioned so that the vertical slab joints are staggered and overlapped at the building corners, ensuring that the slab joints do not occur within 200 mm of the corners of openings (see Figure 3). Joints between slabs greater than 2 mm must be filled with slivers of insulation slab or low density polyurethane foam. Gaps greater than 10 mm must be closed by repositioning or, where appropriate, by cutting slabs to fit. Any high spots or irregularities should be removed.

Figure 3 Typical arrangement of insulation slabs

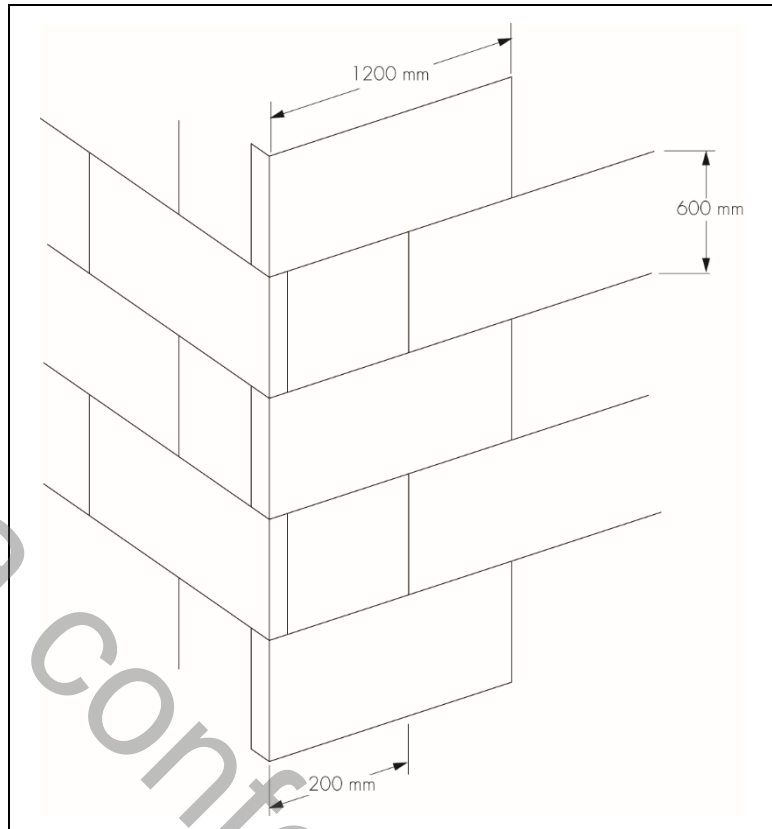

16.10 To fit around details such as doors and windows, insulation slabs may be cut with a sharp knife or a fine-toothed saw. If required, purpose-made window sills designed to prevent water ingress and incorporating drips to shed water clear of the systems are fitted at this stage.

16.11 Installation continues until the whole wall is completely covered including, where appropriate, the building soffits. Alignment should be checked as work proceeds.

16.12 Window and door reveals should be insulated to minimise the effects of cold bridging. Where clearance is limited, strips of approved insulation should be installed to suit available margins and details.

16.13 Prior to the application of the render systems, a bead of joint sealant is gun-applied at window and door frames, overhanging eaves, gas and electric meter boxes, and wall vents, or where the render abuts any other building material or surface.

#### **Movement joints**

16.14 Generally, movement joints are not required in the systems but, if such a joint is already incorporated in the substrate, a movement joint must be included (see Figure 4). Specific types of joint have not been assessed as part of these systems and advice should be sought from the Certificate holder.

Figure 4 Typical movement joint

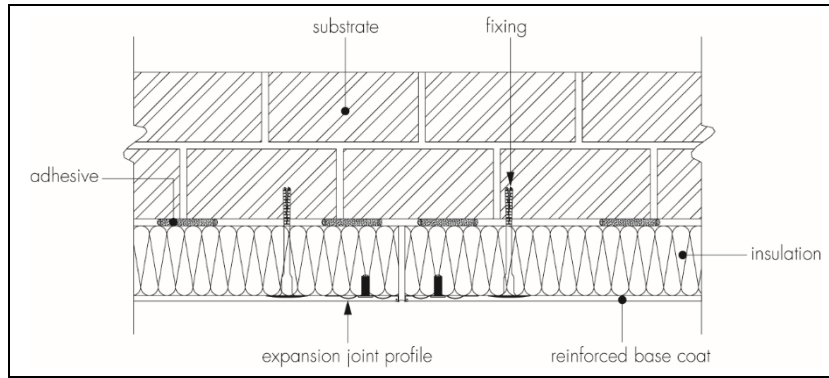

**Application of 30-year durability systems — mechanical fixings through the insulation**

16.15 For a 30-year durability, the slabs are adhesively fixed to the substrate and holes are drilled into the substrate through the insulation slab in a 'saltire' fixing pattern, to a specified minimum depth. Mechanical fixings are applied through each slab to an equivalent of seven fixings per m<sup>2</sup> (see Figure 5). The mechanical fixings are tapped firmly into place, securing the insulation to the substrate.

Figure 5 30-years durability — fixing pattern

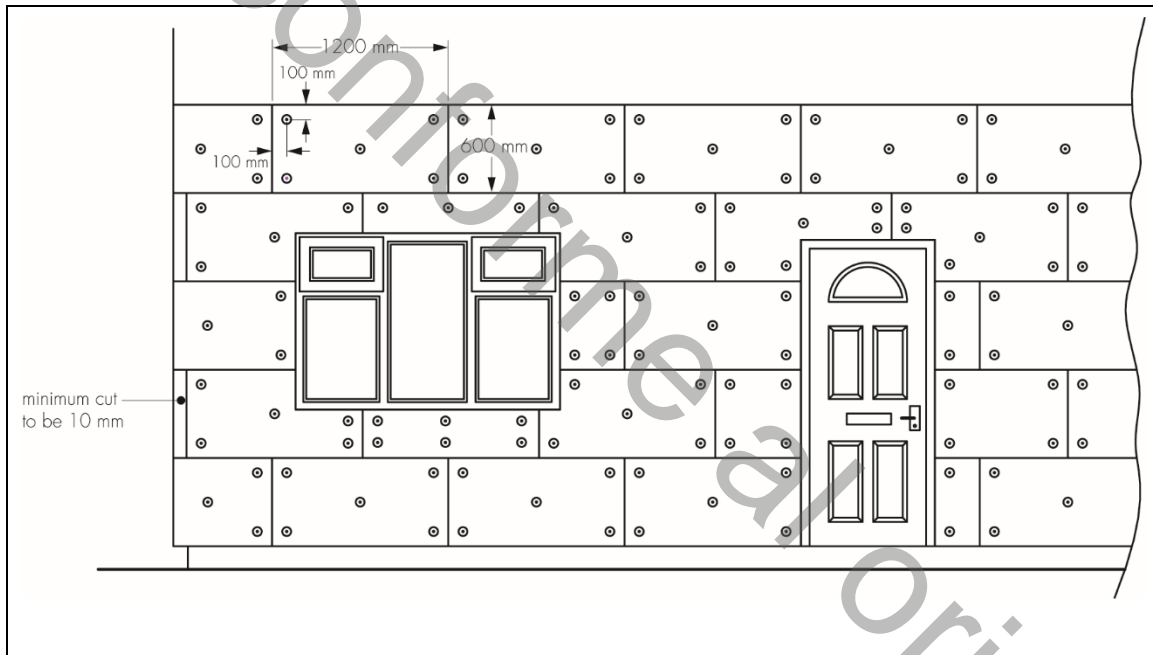
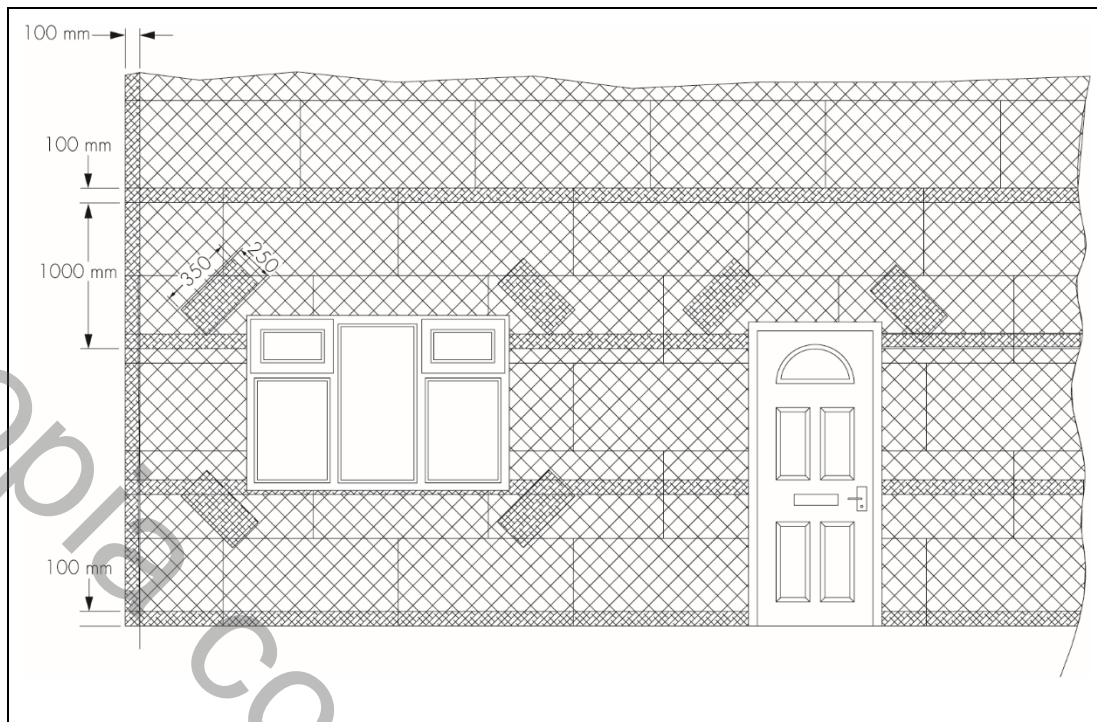

Figure 6 Reinforcement at openings



16.16 The basecoat is prepared with the required amount of water (see section 1.3), then applied over the insulation slabs using a stainless steel trowel, and floated with a Darby float to an approximate 3 mm thickness.

16.17 Prior to the application of reinforcing mesh, diagonal reinforcement patches (approximate size 350 by 250 mm) are embedded at the corners of windows and doors and other building openings so that they extend equally either side of the corner (see Figure 6).

16.18 The reinforcing mesh is immediately applied and embedded into the basecoat by trowelling from the centre to the edge, and an additional light coat of basecoat is applied (while the first coat is still wet) to ensure the mesh is free of wrinkles; overlapping at all mesh joints should not be less than 100 mm.

16.19 Further basecoat is applied as required, to ensure the mesh is completely covered and the required overall minimum 6 mm thickness of basecoat is achieved. The overall thickness of the reinforced basecoat must not be greater than 10 mm.

16.20 The basecoat is applied progressively, working in one-metre sections in a vertical or horizontal direction. The application of the basecoat render continues, following the procedures in section 16.29.

#### **Application of 60-year durability systems — mechanical fixings through the mesh**

16.21 For a 60-year durability, the slabs are adhesively fixed to the substrate and holes are drilled through the insulation slab (two per slab) into the substrate wall. Mechanical fixings are inserted and tapped or screwed firmly into place, to secure slabs during installation of the systems.

16.22 The basecoat is trowel-applied to the surface of the insulation to a thickness of 3 mm.

16.23 Reinforcing mesh is immediately applied and embedded into the basecoat using the trowel, and overlapped at all mesh joints by not less than 100 mm.

16.24 It is important to ensure that the mesh is free of wrinkles, completely covered and that the required minimum thickness of basecoat is achieved.

16.25 While the basecoat is still wet, further holes are drilled, this time through the reinforcing mesh and insulation slabs into the substrate wall to the required depth at the specified frequency and pattern (to equate to not less than seven fixings per square metre). Around openings, additional fixings should be used at 300 mm centres. The mechanical

fixings are inserted and tapped or screwed firmly into place, securing the mesh and insulation slabs to the substrate wall.

Figure 7 60-years durability — fixing pattern

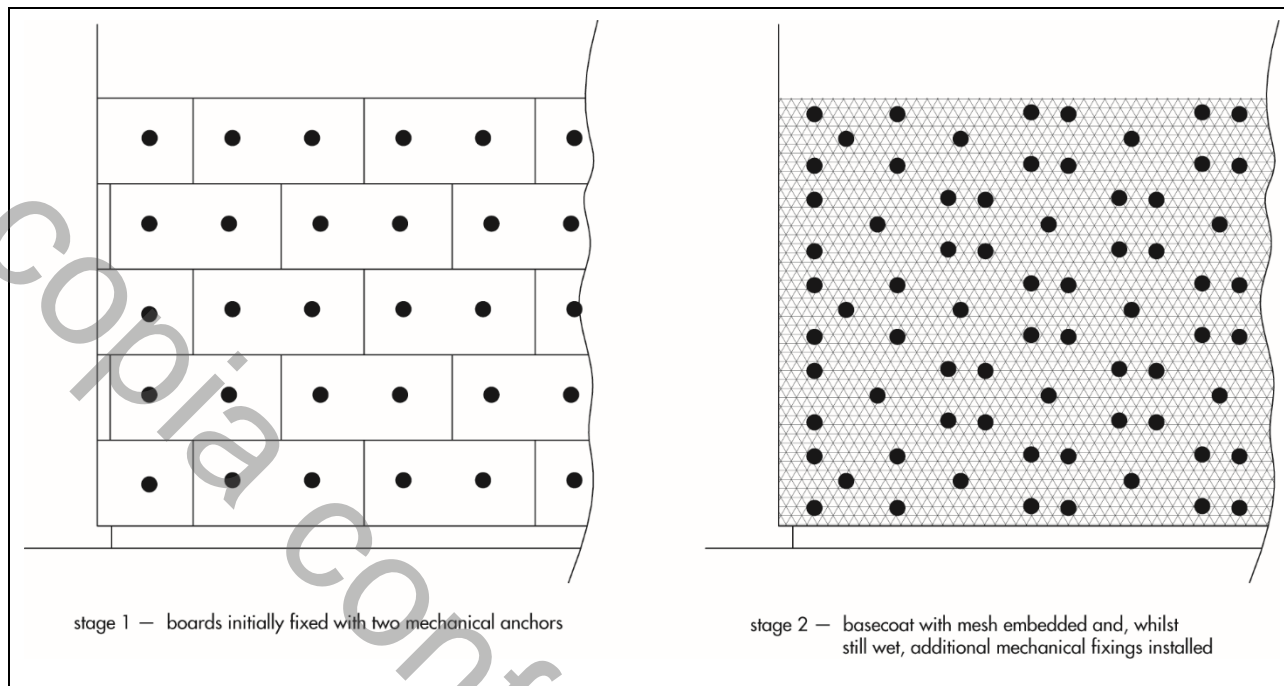

16.26 The fixings are slightly overdriven into the substrate in order to allow the fixing plate to partially penetrate through the basecoat and insulation slabs.

16.27 While the basecoat is still wet, 200 by 200 mm stress patches of reinforcing mesh are applied over the head of the fixings and fully embedded with the basecoat. Further basecoat is applied to maintain a minimum of approximately 4 mm thickness when measured from the top of the fixing head.

16.28 The basecoat is applied progressively, working in one-metre sections in a vertical or horizontal direction.

16.29 For both systems, stop beads are positioned vertically, eg at party wall positions where the adjoining house does not require treatment. Where required, angle beads are fixed to all building corners and to door and window heads and jambs.

16.30 The basecoat should be thoroughly dry before application of the finish coat. The drying time will depend upon the conditions, but at least 48 hours should elapse.

### Finishing

16.31 The render finishes are applied to the required thicknesses (see section 1.3), using a stainless steel trowel and finished with a plastic trowel to create a textured finish. The drying time is dependent on conditions but will typically be 48 hours.

16.32 The finish coating must be trowel- or roller-applied to give the appropriate textured effect.

16.33 To prevent the finish from drying too rapidly, it should not be applied in direct sunlight. The finished render surface must be protected from rain and frost until the material is dry. Continuous surfaces must be completed without a break, eg working to a wet edge.

## **Brick slips systems**

### ***Clay/ceramic brick slips***

16.34 The GlueFlex Ultra bedding mortar adhesive is mixed with a low-speed drill with approximately 6.5 to 7 litres of clean water until a smooth, homogeneous mixture is obtained. The mixture is left to stand for 5 to 7 minutes and then remixed for a short period before applying with a 3 to 5 mm notched trowel to the entire surface of the primed basecoat, to achieve a thickness of between 3 and 5 mm.

16.35 If required, the Termok8 metal lath mesh is applied over the face of the cured base coat, with additional mechanical fixings.

16.36 The clay/ceramic brick slips are applied by hand in a brick bond fashion, lined and levelled into the mortar adhesive. Any smoothing of the mortar should be carried out within 60 minutes.

16.37 Joints between the slips are normally 10 mm wide and are created using plastic spacers. The adhesive is left to cure for 48 hours before pointing the joints using grouting/pointing mortar which is applied using bag, gun or hand application. Once the pointing mortar has stiffened, it should be smoothed or struck using a suitable pointing tool. Brick slips can be subject to shade variations; they should, therefore, be selected at random from different boxes.

### ***Acrylic brick slips***

16.38 Acrylic primer is applied by roller or brush. The primer should be allowed to dry for at least 24 hours before application of the acrylic brick slip adhesive. The adhesive is applied using a 5 mm notch trowel to the entire surface of the primed basecoat, in workable sections.

16.39 Aliva Lightweight Brick Slips are applied by hand in a brick bond fashion, lined and levelled into adhesive. Joints are normally 10 mm wide and, when pointing, a suitably sized brush is used to smooth out the adhesive once it has stiffened into the joints. Aliva Lightweight Brick Slips can be subject to shade variations; they should, therefore, be selected at random from different boxes.

16.40 At the top of walls, the systems should be protected by an adequate overhang (see Figure 8) or by an adequately sealed purpose-made flashing. Care should be taken in the detailing of the system around openings and projections (see Figures 9 to 11).

Figure 8 Typical roof eaves detail

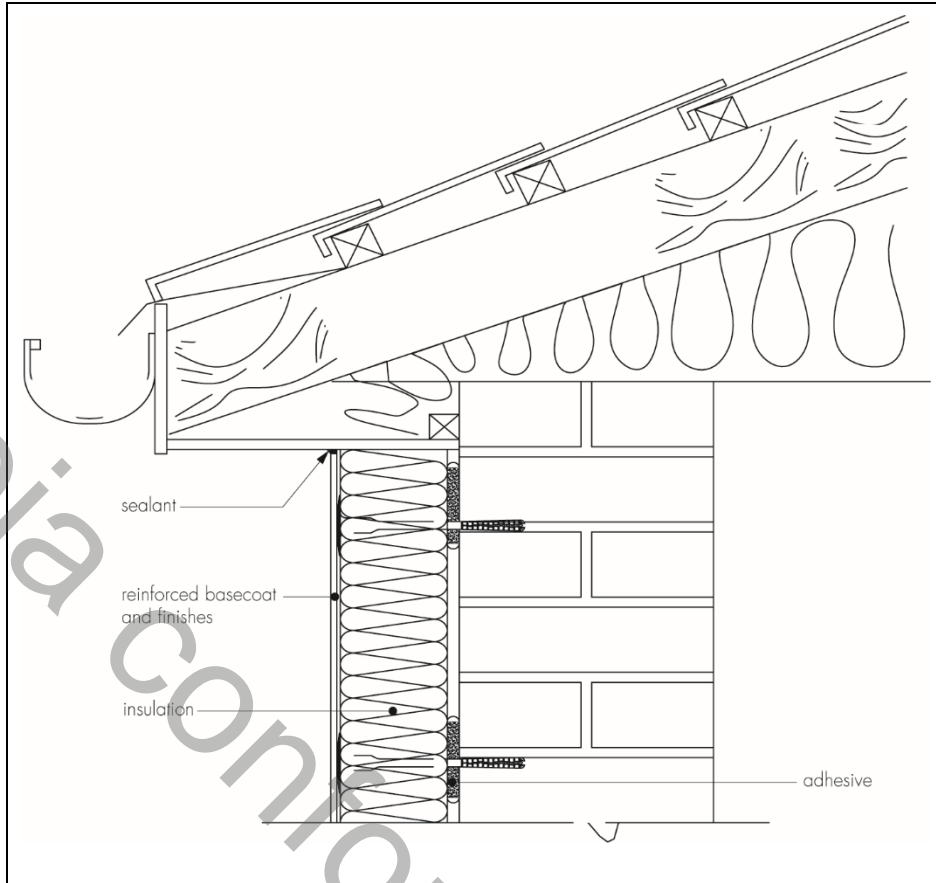

Figure 9 Window head details

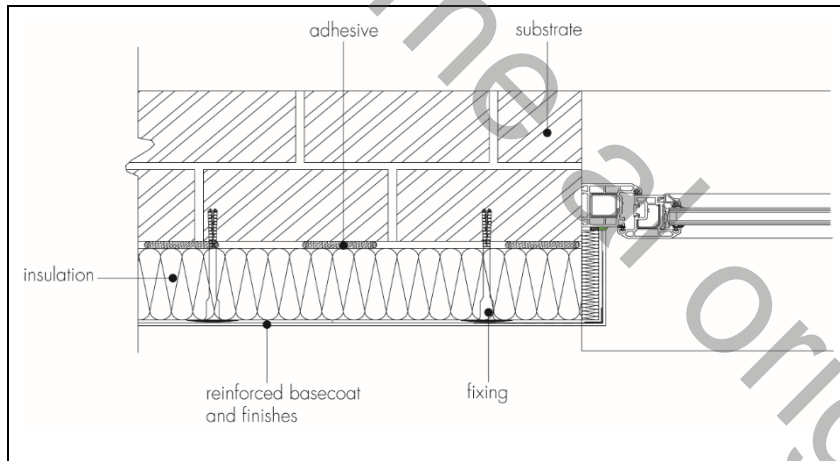

Figure 10 Corner details

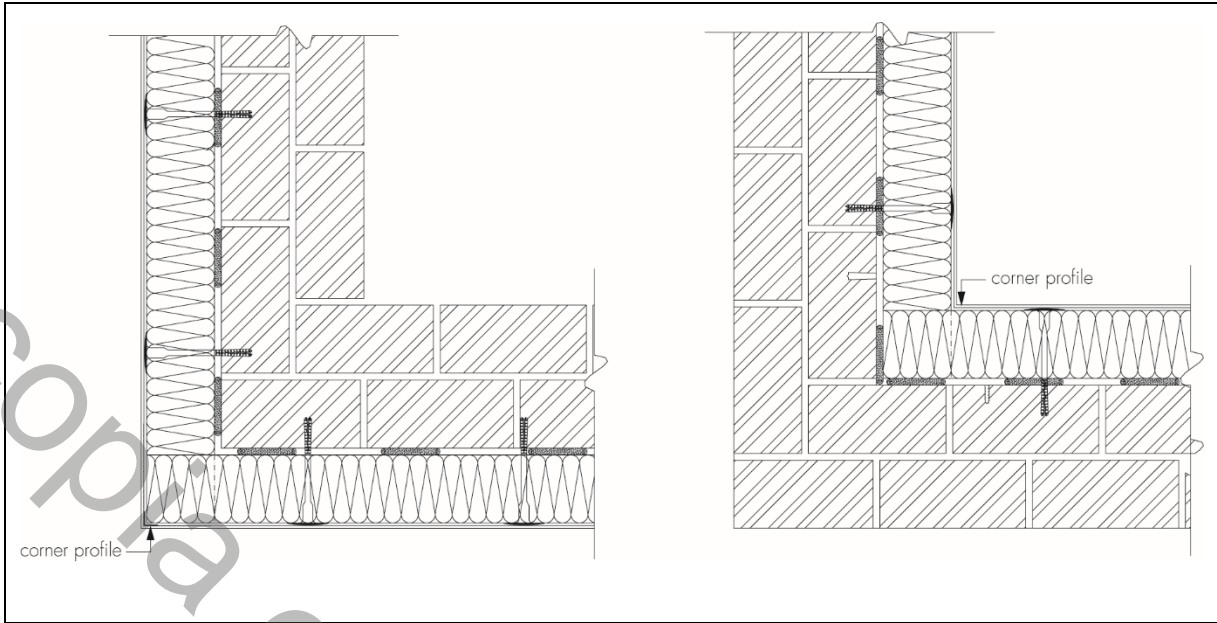
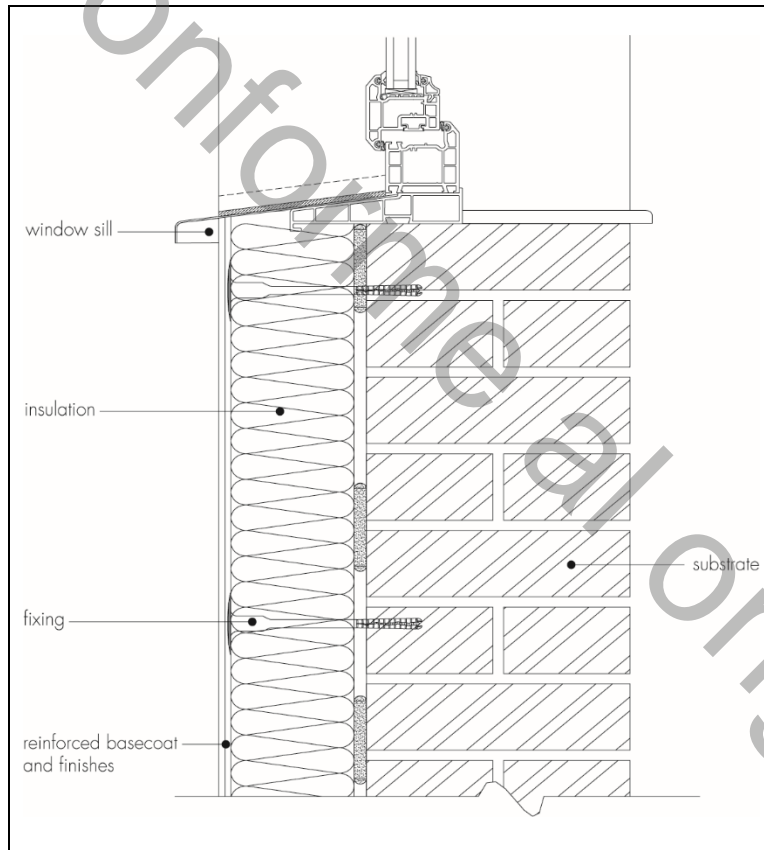

Figure 11 Window sill details



16.41 On completion of the installation, external fittings, eg rainwater goods, are re-fixed through the systems into the substrate.

### 17 Tests

Results of tests were assessed to determine:

- reaction-to-fire
- hygrothermal performance
- capillarity (water absorption)
- water vapour permeability
- bond strength
- hard body impact.

### 18 Investigations

18.1 An examination was made of data relating to:

- durability
- adequacy of the fixings
- the risk of interstitial condensation
- thermal conductivity and example U values
- system wind load resistance.

18.2 The practicability of installation and the effectiveness of detailing techniques were examined.

18.3 The manufacturing process was evaluated, including the methods adopted for quality control, and details were obtained of the quality and composition of the materials used.

## Bibliography

- BRE Report BR 135 : 2013 *Fire performance of external thermal insulation for walls of multi-storey buildings*
- BRE Report BR 262 : 2002 *Thermal insulation: avoiding risks*
- BRE Report BR 443 : 2006 *Conventions for U-value calculations*
- BS 5250 : 2011 *Code of practice for control of condensation in buildings*
- BS 8000-0 : 2014 *Workmanship on construction sites – Introduction and general principles*
- BS 8000-2.2 : 1990 *Workmanship on building sites – Code of practice for concrete work – Sitework with in situ and precast concrete*
- BS 8000-3 : 2001 *Workmanship on building sites – Code of practice for masonry*
- BS EN 197-1 : 2011 *Cement – Composition, specifications and conformity criteria for common cements*
- BS EN 771-1 : 2011 + A1 : 2015 *Specification for masonry units – Clay masonry units*
- BS EN 1990 : 2002 *Eurocode – Basis of structural design*
- BS EN 1991-1-4 : 2005 *Eurocode 1 : Actions on structures – General actions – Wind actions*
- NA to BS EN 1991-1-4 : 2005 UK National Annex to *Eurocode 1 : Actions on structures – General actions – Wind actions*
- BS EN 1992-1-1 : 2004 *Eurocode 2 – Design of concrete structures – General rules and rules for buildings*
- NA to BS EN 1992-1-1 : 2004 *Eurocode 2 – Design of concrete structures – General rules and rules for buildings*
- BS EN 1996-1-1 : 2005 *Eurocode 6 – Design of masonry structures – General rules for reinforced and unreinforced masonry structures*
- NA to BS EN 1996-1-1 : 2005 *Eurocode 6 – Design of masonry structures – General rules for reinforced and unreinforced masonry structures*
- BS EN 1996-2 : 2006 *Eurocode 6 – Design of masonry structures – Design considerations, selection of materials and execution of masonry*
- NA to BS EN 1996-2 : 2006 *Eurocode 6 – Design of masonry structures – Design considerations, selection of materials and execution of masonry*
- BS EN 10088-2 : 2014 *Stainless steel – Technical delivery conditions for sheet/plate and strip of corrosion resisting steels for general purposes*
- BS EN 12004 : 2007 + A1 : 2012 *Adhesives for tiles – Requirements, evaluation of conformity, classification and designation*
- BS EN 13162 : 2012 *Thermal insulation products for buildings – Factory made mineral wool (MW) products – Specification*
- BS EN 13501-1 : 2018 *Fire classification of construction products and building elements – Classification using test data from reaction to fire tests*
- BS EN 13914-1 : 2016 *Design, preparation and application of external rendering and internal plastering – External rendering*
- BS EN ISO 6946 : 2017 *Building components and building elements – Thermal resistance and thermal transmittance – Calculation method*
- BS EN ISO 10456 : 2007 *Building materials and products – Hygrothermal properties—Tabulated design values and procedures for determining declared and design thermal values*
- BS EN ISO 11600 : 2003 + A1 : 2011 *Building construction – Jointing products – Classification and requirements for sealants*
- EAD 330196-00-0604 : 2016 *Plastic Anchors for ETICS*
- EN 13888 : 2009 *Grout for tiles – Requirements, evaluation of conformity, classification and designation*
- EOTA TR051 *Recommendations for job-site tests of plastic anchors and screws*
- ETAG 004 : 2013 *Guideline for European Technical Approval of External Thermal Insulation Composite System with Rendering*
- UNE EN 13501-1 : 2007 + A1 : 2010 *Fire classification of construction products and building elements - Part 1: Classification using data from reaction to fire tests*
- UNI EN 13501-1 : 2019 *Fire classification of construction products and building elements - Part 1: Classification using data from reaction to fire tests*

### 19 Conditions

19.1 This Certificate:

- relates only to the product/system that is named and described on the front page
- is issued only to the company, firm, organisation or person named on the front page – no other company, firm, organisation or person may hold or claim that this Certificate has been issued to them
- is valid only within the UK
- has to be read, considered and used as a whole document – it may be misleading and will be incomplete to be selective
- is copyright of the BBA
- is subject to English Law.

19.2 Publications, documents, specifications, legislation, regulations, standards and the like referenced in this Certificate are those that were current and/or deemed relevant by the BBA at the date of issue or reissue of this Certificate.

19.3 This Certificate will remain valid for an unlimited period provided that the product/system and its manufacture and/or fabrication, including all related and relevant parts and processes thereof:

- are maintained at or above the levels which have been assessed and found to be satisfactory by the BBA
- continue to be checked as and when deemed appropriate by the BBA under arrangements that it will determine
- are reviewed by the BBA as and when it considers appropriate.

19.4 The BBA has used due skill, care and diligence in preparing this Certificate, but no warranty is provided.

19.5 In issuing this Certificate the BBA is not responsible and is excluded from any liability to any company, firm, organisation or person, for any matters arising directly or indirectly from:

- the presence or absence of any patent, intellectual property or similar rights subsisting in the product/system or any other product/system
- the right of the Certificate holder to manufacture, supply, install, maintain or market the product/system
- actual installations of the product/system, including their nature, design, methods, performance, workmanship and maintenance
- any works and constructions in which the product/system is installed, including their nature, design, methods, performance, workmanship and maintenance
- any loss or damage, including personal injury, howsoever caused by the product/system, including its manufacture, supply, installation, use, maintenance and removal
- any claims by the manufacturer relating to CE marking.

19.6 Any information relating to the manufacture, supply, installation, use, maintenance and removal of this product/system which is contained or referred to in this Certificate is the minimum required to be met when the product/system is manufactured, supplied, installed, used, maintained and removed. It does not purport in any way to restate the requirements of the Health and Safety at Work etc. Act 1974, or of any other statutory, common law or other duty which may exist at the date of issue or reissue of this Certificate; nor is conformity with such information to be taken as satisfying the requirements of the 1974 Act or of any statutory, common law or other duty of care.